

# STRAIGHT SHANK TOOL HOLDER CATEGORY

NC / ER COLLET CHUCK	T-2
STRAIGHT SHANK ER COLLET CHUCK	T-3~6
ER COLLET CHUCK SYSTEM [FOR AUTOMATIC LATHE]	T-7~8
ER TAPPER [FOR CNC LATHE]	T-9
STRAIGHT SHANK SBL COLLET CHUCK	T-10
STRAIGHT SHANK SIDE LOCK HOLDER	T-11

# NC / ER COLLET CHUCK



## NC / ER 夾頭柄



T W PAT NO. M298033  
 T W PAT NO. M311791  
 T W PAT NO. M186381  
 J P PAT NO. 3128766  
 K R PAT NO. 20-0433603  
 C N PAT NO. ZL200620132661.0  
 C H PAT NO. 696550  
 T R PAT NO. TR 2007 02942 Y  
 I T PAT NO. N.0000266731

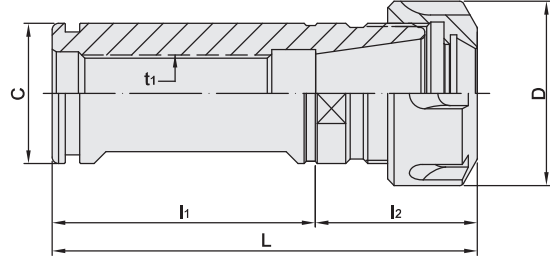

MODEL NO.	TYPE	L	l <sub>1</sub>	l <sub>2</sub>	D	C	t <sub>1</sub>	WEIGHT (KGS)
04762	C32 x NC/ER25 - 60	97	60	37	42	32	M18 x 1.5P	0.70
04764	C32 x NC/ER32 - 60	103	60	43	50	32	M22 x 1.5P	0.75
04766	C40 x NC/ER32 - 80	118	80	38	50	40	M22 x 1.5P	1.25
04768	C40 x NC/ER40 - 75	135	75	60	63	40	M28 x 1.5P	1.30
04770	C45 x NC/ER32 - 120	178	120	58	50	45	M22 x 1.5P	1.60
04772	C45 x NC/ER40 - 120	180	120	60	63	45	M28 x 1.5P	1.65
04782	C1-1/4" x NC/ER25 - 60	97	60	37	42	31.75	M18 x 1.5P	0.70
04784	C1-1/4" x NC/ER32 - 60	103	60	43	50	31.75	M22 x 1.5P	0.75
04786	C1-1/4" x NC/ER40 - 60	120	60	60	63	31.75	M22 x 1.5P	0.84
04788	C1-1/2" x NC/ER32 - 80	118	80	38	50	38.1	M22 x 1.5P	1.25
04790	C1-1/2" x NC/ER40 - 75	135	75	60	63	38.1	M28 x 1.5P	1.30

### Features:

- ▶ This is specially suitable for CNC Machines but can also be used for general machines.
- ▶ At the end of body, there's an O-ring for sealing.

### Standard Accessory: • NUT

Collet	Nut	Preset Screw	Spanner
P.W-6~24	P.W-42	P.W-82	P.W-62~65

# STRAIGHT SHANK ER COLLET CHUCK



直柄 ER 夾頭柄

[DIN ISO 15488]

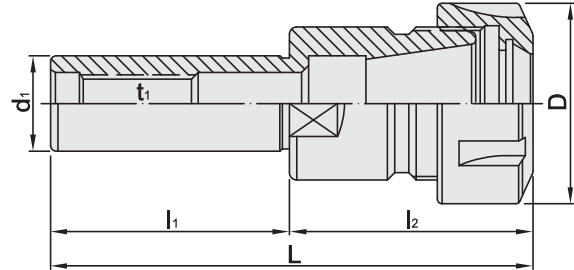

T W PAT NO. M298033  
T W PAT NO. M311791  
T W PAT NO. M186381  
J P PAT NO. 3128766  
K R PAT NO. 20-0433603  
C N PAT NO. ZL200620132661.0  
C H PAT NO. 696550  
T R PAT NO. TR 2007 02942 Y  
I T PAT NO. N.0000266731

MODEL NO.	TYPE	L	l <sub>1</sub>	l <sub>2</sub>	D	d <sub>1</sub>	t <sub>1</sub>	WEIGHT (KGS)
04851	C16 x ER11A - 140	156.6	140	16.6	19	16	M6 x 1.0P	0.23
04802	C16 x ER16A - 50	90	50	40	28	16	M10 x 1.5P	0.15
04803	C16 x ER16A - 100	140	100	40	28	16	M10 x 1.5P	0.20
04804	C16 x ER16A - 150	190	150	40	28	16	M10 x 1.5P	0.28
04806	C20 x ER16A - 50	90	50	40	28	20	M12 x 1.75P	0.25
04807	C20 x ER16A - 100	140	100	40	28	20	M12 x 1.75P	0.35
04808	C20 x ER16A - 150	190	150	40	28	20	M12 x 1.75P	0.40
04810	C20 x ER20A - 60	100.5	60	40.5	34	20	M12 x 1.75P	0.35
04811	C20 x ER20A - 120	160.5	120	40.5	34	20	M12 x 1.75P	0.40
04812	C20 x ER20A - 180	220.5	180	40.5	34	20	M12 x 1.75P	0.50
04814	C20 x ER25 - 50	101	50	51	42	20	M12 x 1.75P	0.35
04815	C20 x ER25 - 100	151	100	51	42	20	M12 x 1.75P	0.40
04817	C20 x ER32 - 50	101.5	50	51.5	50	20	M12 x 1.75P	0.45
04818	C20 x ER32 - 100	151.5	100	51.5	50	20	M10 x 1.5P	0.42
04819 - 150	C25 x ER16A - 150	176.6	150	26.6	28	25	M10 x 1.5P	0.55
04820	C25 x ER25 - 50	101	50	51	42	25	M16 x 2.0P	0.40
04821	C25 x ER25 - 100	151	100	51	42	25	M16 x 2.0P	0.50
04823	C25 x ER32 - 50	101.5	50	51.5	50	25	M16 x 2.0P	0.60
04823 - 100	C25 x ER32 - 100	151.5	100	51.5	50	25	M16 x 2.0P	0.80
04825	C25 x ER40 - 50	115	50	65	63	25	M16 x 2.0P	2.10
04820 - C32	C32 x ER25 - 50	101	50	50	42	32	M16 x 2.0P	1.00
04827	C32 x ER32 - 60	111.5	60	51.5	50	32	M16 x 2.0P	1.15
04827 - 100	C32 x ER32 - 100	151.5	100	51.5	50	32	M16 x 2.0P	1.40
04829	C32 x ER40 - 50	115	50	65	63	32	M16 x 2.0P	2.00

**Features:**

- ▶ Each body has been locked with a nut as attachment, but without a spanner and collets.
- ▶ For complete set, please refer to P.T-7.

**Standard Accessory: • NUT**

Collet	Nut	Preset Screw	Spanner
P.W-6~24	P.W-42	P.W-82	P.W-62~65



# STRAIGHT SHANK ER COLLET CHUCK



直柄 ER 夾頭柄

[DIN ISO 15488]



T W PAT NO. M298033  
T W PAT NO. M311791  
T W PAT NO. M186381  
J P PAT NO. 3128766  
K R PAT NO. 20-0433603  
C N PAT NO. ZL200620132661.0  
C H PAT NO. 696550  
T R PAT NO. TR 2007 02942 Y  
I T PAT NO. N.0000266731

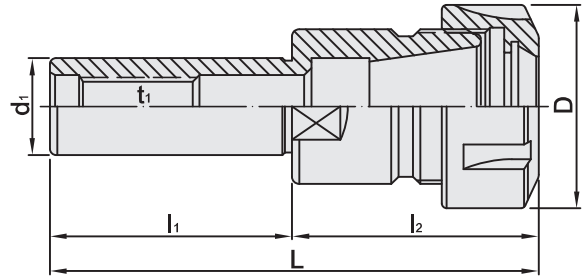

MODEL NO.	TYPE	L	l <sub>1</sub>	l <sub>2</sub>	D	d <sub>1</sub>	t <sub>1</sub>	WEIGHT (KGS)
04855	C1/2" x ER11A - 140	156.6	140	16.6	19	12.7	M6 x 1.0P	0.50
04854	C5/8" x ER11A - 140	156.6	140	16.6	19	15.875	M6 x 1.0P	0.23
04832	C5/8" x ER16A - 60	95.1	60	35.1	28	15.875	M10 x 1.5P	0.12
04834	C3/4" x ER16A - 50	85.1	50	35.1	28	19.05	M10 x 1.5P	0.20
04835	C3/4" x ER16A - 100	135.1	100	35.1	28	19.05	M10 x 1.5P	0.25
04856	C3/4" x ER16A - 140	175.1	140	35.1	28	19.05	M10 x 1.5P	0.25
04836 - 2.5	C3/4" x ER20A - 63.5	104	63.5	40.5	34	19.05	M12 x 1.75P	1.00
04858	C1" x ER20A - 140	167.5	140	27.5	34	25.4	M12 x 1.75P	0.50
04837	C1" x ER25 - 50	101	50	51	42	25.4	M16 x 2.0P	0.95
04839	C1" x ER32 - 50	101.5	50	51.5	50	25.4	M16 x 2.0P	1.00
04839 - 140	C1" x ER32 - 140	191.5	140	51.5	50	25.4	M16 x 2.0P	1.50
04841	C1" x ER40 - 50	115	50	65	63	25.4	M16 x 2.0P	2.10
04843	C1-1/4" x ER32 - 60	111.5	60	51.5	50	31.75	M16 x 2.0P	1.15

**Features:**

- ▶ Each body has been locked with a nut as attachment, but without a spanner and collets.
- ▶ For complete set, please refer to P.T-7.

**Standard Accessory: • NUT**

Collet	Nut	Preset Screw	Spanner
P.W-6~24	P.W-42	P.W-82	P.W-62~65

# STRAIGHT SHANK ER COLLET CHUCK MINI TYPE



小徑 / 直柄 ER 夾頭柄

(DIN ISO 15488)

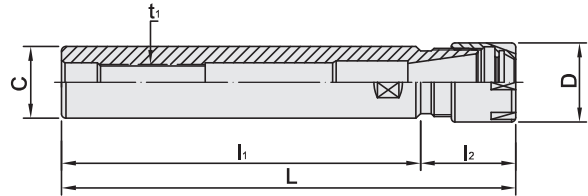

T W PAT NO. M298033  
 T W PAT NO. M311791  
 T W PAT NO. M186381  
 J P PAT NO. 3128766  
 K R PAT NO. 20-0433603  
 C N PAT NO. ZL200620132661.0  
 C H PAT NO. 696550  
 T R PAT NO. TR 2007 02942 Y  
 I T PAT NO. N.0000266731

MODEL NO.	TYPE	L	l <sub>1</sub>	l <sub>2</sub>	D	C	t <sub>1</sub>	WEIGHT (KGS)
04860	C8 x ER8M - 55	78.2	55	23.2	12	8	-	0.05
04861 - 100	C10 x ER8M- 100	116.2	100	16.2	12	10	-	0.11
04861 - 150	C10 x ER8M - 150	166.2	150	16.2	12	10	-	0.12
04861	C10 x ER8M - 180	196.2	180	16.2	12	10	-	0.15
04862	C12 x ER8M - 55	71.2	55	16.2	12	12	-	0.20
04862 - 120	C12 x ER8M - 120	136.2	120	16.2	12	12	-	0.30
04863	C12 x ER11M - 80	96.6	80	16.6	16	12	M5 x 0.8P	0.23
04864	C16 x ER11M - 50	66.6	50	16.6	16	16	M5 x 0.8P	0.25
04865	C16 x ER11M - 100	116.6	100	16.6	16	16	M5 x 0.8P	0.23
04866	C16 x ER11M - 140	156.6	140	16.6	16	16	M5 x 0.8P	0.35
04867	C12 x ER16M - 80	116.6	80	36.6	22	12	M5 x 0.8P	0.38
04868 - 60	C20 x ER16M - 60	86.6	60	26.6	22	20	M10 x 1.5P	0.40
04868	C20 x ER16M - 100	126.6	100	26.6	22	20	M10 x 1.5P	0.42
04869	C20 x ER16M - 140	166.6	140	26.6	22	20	M10 x 1.5P	0.35
04870	C20 x ER16M - 160	186.6	160	26.6	22	20	M10 x 1.5P	0.38
04873	C20 x ER20M - 60	100	60	40	28	20	M12 x 1.75P	0.40
04875	C20 x ER20M - 100	140	100	40	28	20	M12 x 1.75P	0.45
04877	C20 x ER20M - 120	160	120	40	28	20	M12 x 1.75P	0.50
04879	C20 x ER20M - 150	190	150	40	28	20	M12 x 1.75P	0.55
04881	C20 x ER20M - 180	220	180	40	28	20	M12 x 1.75P	0.60
04883	C22 x ER20M - 140	180	140	40	28	22	M12 x 1.75P	0.38
04885	C25 x ER20M - 140	168	140	28	28	25	M12 x 1.75P	0.15
04887	C20 x ER25M - 100	150	100	50	35	20	M12 x 1.75P	0.20

**Features:**

- ▶ Each body has been locked with a nut as attachment, but without a spanner and collets.
- ▶ Not including stop screw, please purchase separately.

**Standard Accessory: • NUT**

Collet	Nut	Preset Screw	Spanner
P.W-6~24	P.W-43	P.W-82	P.W-62~65



# STRAIGHT SHANK ER COLLET CHUCK MINI TYPE



小徑 / 直柄 ER 夾頭柄

[DIN ISO 15488]

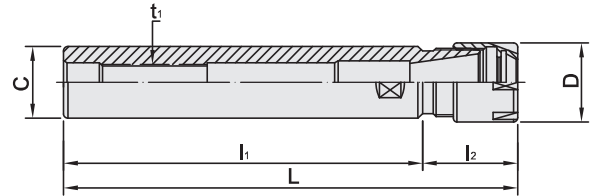

T W PAT NO. M298033  
 T W PAT NO. M311791  
 T W PAT NO. M186381  
 J P PAT NO. 3128766  
 K R PAT NO. 20-0433603  
 C N PAT NO. ZL200620132661.0  
 C H PAT NO. 696550  
 T R PAT NO. TR 2007 02942 Y  
 I T PAT NO. N.0000266731

MODEL NO.	TYPE	L	Li	L2	D	C	ti	WEIGHT (KGS)
04889	C3/8" x ER8M - 100	117	100	17	12	9.525	-	0.23
04890	C1/2" x ER8M - 78	95	78	17	12	12.7	-	0.20
04891	C1/2" x ER11M - 140	156.6	140	16.6	16	12.7	M5 x 0.8P	0.16
04893	C5/8" x ER11M - 140	156.6	140	16.6	16	15.875	M5 x 0.8P	0.20
04888	C1" x ER25M - 140	190	140	50	35	25.4	M16 x 2.0P	0.23
04895	C1/2" x ER16M - 140	177	140	37	22	12.7	M16 x 2.0P	0.50
04896	C3/4" x ER16M - 140	165	140	25	22	19.05	M10 x 1.5P	0.25
04897	C1" x ER20M - 140	168	140	28	28	25.4	M12 x 1.75P	0.50
04898	C3/4" x ER25M - 100	150	100	50	35	19.05	M12 x 1.75P	0.35

**Features:**

- ▶ Each body has been locked with a nut as attachment, but without a spanner and collets.
- ▶ Not including stop screw, please purchase separately.

**Standard Accessory: • NUT**

Collet	Nut	Preset Screw	Spanner
P.W-6~24	P.W-43	P.W-82	P.W-62~65



# DOUBLE-ENDED STRAIGHT SHANK ER COLLET CHUCK FOR AUTOMATIC LATHE



直柄兩端 ER 自動車床用夾頭柄



T W PAT NO. M298033  
 T W PAT NO. M311791  
 T W PAT NO. M186381  
 J P PAT NO. 3128766  
 K R PAT NO. 20-0433603  
 C N PAT NO. ZL200620132661.0  
 C H PAT NO. 696550  
 T R PAT NO. TR 2007 02942 Y  
 I T PAT NO. N.0000266731

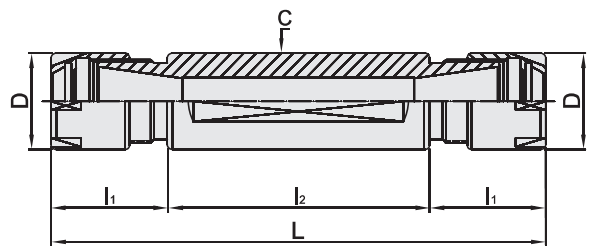

MODEL NO.	TYPE	L	l <sub>1</sub>	l <sub>2</sub>	C	D	WEIGHT (KGS)
05155	DE20 x ER11M - 30	63.2	16.6	30	20	16	0.09
05156	DE20 x ER11M - 50	83.2	16.6	50	20	16	0.12
05157	DE20 x ER11M - 75	108.2	16.6	75	20	16	0.12
05158	DE20 x ER16M - 50	103.2	26.6	50	20	22	0.10
05158 - 55	DE20 x ER16M - 55	108.2	26.6	55	20	22	0.12
05159	DE20 x ER16M - 75	128.2	26.6	75	20	22	0.12
05166	DE22 x ER11M - 60	93.2	16.6	60	22	16	0.12
05167	DE22 x ER11M - 100	133.2	16.6	100	22	16	0.14
05168 - 55	DE22 x ER16M - 55	108.2	26.6	55	22	22	0.17
05168	DE22 x ER16M - 60	113.2	26.6	60	22	22	0.14
05168 - 75	DE22 x ER16M - 75	128.2	26.6	75	22	22	0.21
05169	DE22 x ER16M - 100	153.2	26.6	100	22	22	0.16
05176	DE23 x ER11M - 60	93.2	16.6	60	23	16	0.16
05177	DE23 x ER11M - 100	133.2	16.6	100	23	16	0.18
05178	DE23 x ER16M - 60	113.2	26.6	60	23	22	0.20
05179	DE23 x ER16M - 100	153.2	26.6	100	23	22	0.21
05182	DE25 x ER16M - 62	115.2	26.6	62	25	22	0.23

- ▶ Hardness: body 56°-60°HRC, thread 44°-46°HRC, Two-parted rigidity design.
- ▶ The concentricity of the internal hole is 0.005mm, which extends tool life.
- ▶ The tolerance of the chuck's diameter is -0.005-0.008mm with high operation efficiency.
- ▶ The flat side of the holder is for the side lock screw to fasten.
- ▶ Compatible with three kinds of ER collets-0.015mm (Class standard), 0.01mm(Class A) and 0.005mm(Class UP), which are graded by their precision.
- ▶ TYPE C20 is suitable for the brand, TAKAMAZ CITIZEN MIYANO, conforming to SWISS MODEL.
- ▶ TYPE C22 is suitable for the brand, STAR, conforming to the SWISS MODEL.
- ▶ TYPE C23 is suitable for the brand, NOMURA, conforming to the SWISS MODEL.

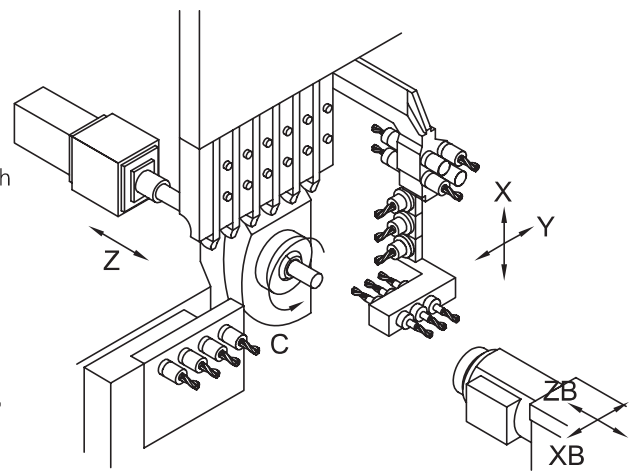

**Standard Accessory: • NUT**

Collet	Nut	Preset Screw	Spanner
P.W-6~24	P.W-43	P.W-82	P.W-62~65



# STRAIGHT SHANK ER COLLET CHUCK FOR AUTOMATIC LATHE



小徑 / 直柄 ER 自動車床用夾頭柄



T W PAT NO. M298033  
T W PAT NO. M311791  
T W PAT NO. M186381  
J P PAT NO. 3128766  
K R PAT NO. 20-0433603  
C N PAT NO. ZL200620132661.0  
C H PAT NO. 696550  
T R PAT NO. TR 2007 02942 Y  
I T PAT NO. N.0000266731

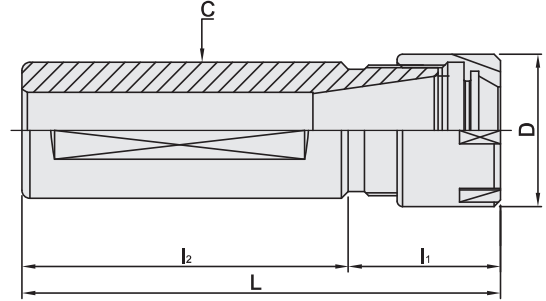

MODEL NO.	TYPE	L	l <sub>1</sub>	l <sub>2</sub>	C	D	WEIGHT (KGS)
05272	C20 x ER11M - 60	76.6	16.6	60	20	16	0.14
05274	C20 x ER16M - 60	84.6	24.6	60	20	22	0.14
05278	C22 x ER11M - 60	76.6	16.6	60	22	16	0.26
05280	C22 x ER16M - 60	84.6	24.6	60	22	22	0.28
05286	C23 x ER11M - 60	76.6	16.6	60	23	16	0.30
05288	C23 x ER16M - 60	86.6	26.6	60	23	22	0.32
05298	C25 x ER20M - 60	88	28	60	25	28	0.22

### Standard Accessory: • NUT

Collet	Nut	Spanner
P.W-6~24	P.W-43	P.W-62~65



# STRAIGHT SHANK ER TAPPER FOR CNC LATHE



直柄伸縮 ER 攻牙器 [ CNC車床專用 ]



T W PAT NO. M298033  
T W PAT NO. M311791  
T W PAT NO. M186381  
J P PAT NO. 3128766  
K R PAT NO. 20-0433603  
C N PAT NO. ZL200620132661.0  
C H PAT NO. 696550  
T R PAT NO. TR 2007 02942 Y  
I T PAT NO. N.0000266731

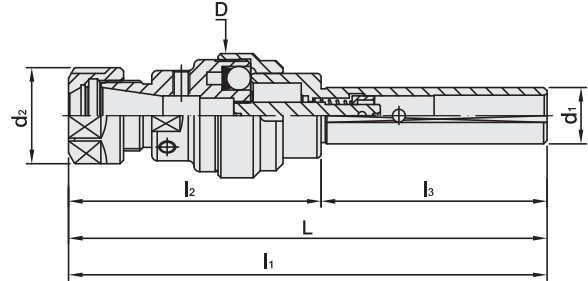

MODEL NO.	TYPE	D	d <sub>1</sub>	d <sub>2</sub>	L	l <sub>1</sub>	l <sub>2</sub>	l <sub>3</sub>	CAPACITY	WEIGHT (KGS)
05205	TP - 20	44	20	34	159	172	79	80	M3 ~ M16	0.50
05206	TP - 225	44	25	34	159	172	79	80	M3 ~ M16	0.70
05207	TP - 232	44	32	34	159	172	79	80	M3 ~ M16	0.90
05208	STP - 20	37	20	34	155	172	79	80	M3 ~ M16	1.00
05215	TP - 32	56	32	50	174.5	190	94.5	80	M3 ~ M27	1.60
05225	TPM - 320	44	MT3	34	165	178	79	86	M3 ~ M16	1.40
05235	TPM - 420	44	MT4	34	165	178	79	86	M3 ~ M16	1.60
05245	TPM - 432	56	MT4	50	203.5	216.5	94.5	109	M3 ~ M27	1.80

### Features:

- ▶ Used with ER Rigid Tap Collet or ER Collet to hold taps.
- ▶ Flexible design. Can avoid any tap breakage resulting from overdoing, spindle's counterclockwise turning and turret moving.
- ▶ Good floating assembly, can be automatic to correct deviation of repeated position in workpiece.
- ▶ 05225, 05235 and 05245 are designed to tighten the tool holder and ER taper by inside thread. There are metric type and inch type for the inside thread. Please inform us which type you need when making an order.

### NOTE:

- ▶ If the processing material is harder, the M/min becomes slower relatively.
- ▶ Before using the Straight Shank ER Tapper, please decide spindle running speed of Lathe Machine; otherwise, it will make the Shank and Tap break or split because of too fast or too slow speed.

### Standard Accessory: • NUT

Collet	Nut	Spanner
P.W-6~24	P.W-42	P.W-62~65



# STRAIGHT SHANK SBL COLLET CHUCK

直柄 SBL 小徑延長桿

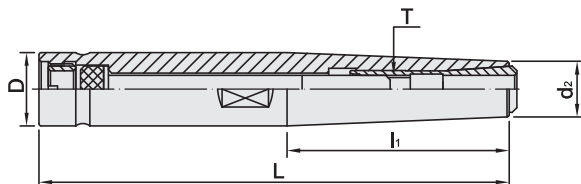

MODEL NO.	TYPE	L	l <sub>1</sub>	D	d <sub>2</sub>	T	WEIGHT (KGS)
06002	C12 x SBL6 - 120	120	-	12	12	M6 x 1.0P	0.16
06004	C12 x SBL6 - 150	150	-	12	12	M6 x 1.0P	0.18
06008	C16 x SBL6 - 120	120	48	16	12	M6 x 1.0P	0.21
06010	C16 x SBL6 - 150	150	48	16	12	M6 x 1.0P	0.22
06012	C16 x SBL6 - 200	200	48	16	12	M6 x 1.0P	0.24
06014	C20 x SBL6 - 120	120	76.5	20	12	M6 x 1.0P	0.36
06016	C20 x SBL6 - 150	150	86	20	12	M6 x 1.0P	0.23
06018	C20 x SBL6 - 200	200	76.5	20	12	M6 x 1.0P	0.25
06020	C25 x SBL6 - 120	120	60	25	14	M6 x 1.0P	0.33
06022	C25 x SBL6 - 150	150	60	25	14	M6 x 1.0P	0.34
06024	C25 x SBL6 - 200	200	60	25	14	M6 x 1.0P	0.36
06026	C25 x SBL12 - 120	120	50	25	22	M10 x 1.5P	0.34
06028	C25 x SBL12 - 150	150	50	25	22	M10 x 1.5P	0.35
06030	C25 x SBL12 - 200	200	50	25	22	M10 x 1.5P	0.37
06032	1/2" x SBL6 - 5"	127	48	12.7	12	M6 x 1.0P	0.16
06034	1/2" x SBL6 - 6"	152.4	48	12.7	12	M6 x 1.0P	0.18
06038	5/8" x SBL6 - 5"	127	48	15.875	12	M6 x 1.0P	0.21
06040	5/8" x SBL6 - 6"	152.4	48	15.875	12	M6 x 1.0P	0.22
06042	5/8" x SBL6 - 8"	203.2	48	15.875	12	M6 x 1.0P	0.24
06044	3/4" x SBL6 - 5"	127	76.5	19.05	12	M6 x 1.0P	0.22
06046	3/4" x SBL6 - 6"	152.4	86	19.05	12	M6 x 1.0P	0.23
06048	3/4" x SBL6 - 8"	203.2	76.5	19.05	12	M6 x 1.0P	0.25
06050	1" x SBL6 - 5"	127	60	25.4	14	M6 x 1.0P	0.33
06052	1" x SBL6 - 6"	152.4	60	25.4	14	M6 x 1.0P	0.34
06054	1" x SBL6 - 8"	203.2	60	25.4	14	M6 x 1.0P	0.36
06058	1" x SBL12 - 5"	127	56	25.4	22	M10 x 1.5P	0.34
06060	1" x SBL12 - 6"	152.4	56	25.4	22	M10 x 1.5P	0.35
06062	1" x SBL12 - 8"	203.2	56	25.4	22	M10 x 1.5P	0.37

**Standard Accessory: • SPANNER**

Collet	Spanner
	
P.W-29~30	P.W-66

# STRAIGHT SHANK SIDE LOCK HOLDER

C / SL 直柄側固式延長小徑刀柄

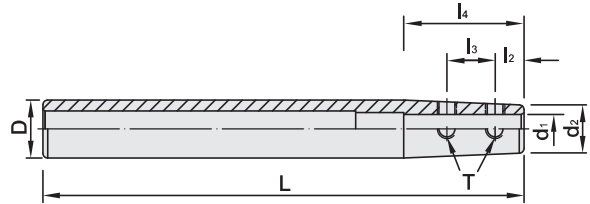

MODEL NO.	TYPE	L	l <sub>2</sub>	l <sub>3</sub>	l <sub>4</sub>	D	d <sub>1</sub>	d <sub>2</sub>	T	WEIGHT (KGS)
07104	C8 x SL4 - 110	110	6	10	25	8	4	8	M3 x 0.5P	0.10
07112	C10 x SL3 - 150	150	6	10	25	10	3	9	M3 x 0.5P	0.10
07114	C10 x SL4 - 150	150	6	10	25	10	4	9	M4 x 0.7P	0.10
07116	C10 x SL6 - 150	150	6	10	25	10	6	-	M4 x 0.7P	0.10
07118	C12 x SL4 - 150	150	6	10	25	12	4	9	M4 x 0.7P	0.12
07120	C12 x SL6 - 100	100	6	10	25	12	6	10	M4 x 0.7P	0.10
07122	C12 x SL6 - 150	150	6	10	25	12	6	10	M4 x 0.7P	0.12
07124	C16 x SL4 - 150	150	6	10	25	16	4	10	M4 x 0.7P	0.15
07126	C16 x SL4 - 200	200	6	10	25	16	4	10	M4 x 0.7P	0.18
07128	C16 x SL6 - 150	150	6	10	25	16	6	13	M4 x 0.7P	0.15
07130	C16 x SL6 - 200	200	6	10	25	16	6	13	M4 x 0.7P	0.18
07132	C16 x SL8 - 150	150	6	10	25	16	8	15	M4 x 0.7P	0.15
07134	C16 x SL8 - 200	200	6	10	25	16	8	15	M4 x 0.7P	0.18
07138	C20 x SL6 - 150	150	6	10	25	20	6	13	M4 x 0.7P	0.18
07140	C20 x SL8 - 150	150	6	10	25	20	8	15	M6 x 1.0P	0.18
07142	C20 x SL8 - 200	200	6	10	25	20	8	15	M6 x 1.0P	0.18
07144	C20 x SL10 - 150	150	6	10	25	20	10	17	M6 x 1.0P	0.18
07146	C20 x SL10 - 200	200	6	10	25	20	10	17	M6 x 1.0P	0.20
07148	C20 x SL12 - 150	150	6	10	25	20	12	19	M6 x 1.0P	0.18
07150	C20 x SL12 - 200	200	6	10	25	20	12	19	M6 x 1.0P	0.20
07152	C32 x SL6 - 150	150	6	10	25	32	6	13	M6 x 1.0P	0.21
07154	C32 x SL8 - 150	150	6	10	25	32	8	15	M6 x 1.0P	0.21
07156	C32 x SL10 - 150	150	6	10	25	32	10	17	M6 x 1.0P	0.22
07158	C32 x SL12 - 150	150	6	10	25	32	12	19	M6 x 1.0P	0.22

## Features:

- ▶ d1 is H5.

