

SDAT CATEGORY

PNER COLLET CHUCK	F-3
UT COLLET CHUCK	F-4~5
ER COLLET CHUCK	F-6~7
ER COLLET CHUCK [M TYPE]	F-8
SKX COLLET CHUCK	F-9~10
SK3 COLLET CHUCK	F-11
SKS COLLET CHUCK	F-12
SBL SLIM-FIT COLLET CHUCK	F-13
SBLC SLIM-FIT COLLET CHUCK	F-14
MLD MULTI-LOCK MILLING CHUCK	F-15
SLN SIDE LOCK END MILL HOLDER	F-16
FACE MILL ARBOR [FMB TYPE]	F-17
FACE MILL ARBOR [FMC TYPE]	F-18
MORSE TAPER ADAPTER	F-19
ADAPTER	F-20

SDAT / PNER COLLET CHUCK



SDAT / PNER 法蘭加厚型立銑刀夾頭



T W PAT NO. M298033
 T W PAT NO. M311791
 T W PAT NO. M501316
 J P PAT NO. 3128766
 J P PAT NO. 3200356
 K R PAT NO. 20-0433603
 C N PAT NO. ZL200620132661.0
 C H PAT NO. 696550
 T R PAT NO. TR 2007 02942 Y
 I T PAT NO. N.0000266731
 D E PAT NO. Nr.202015005621

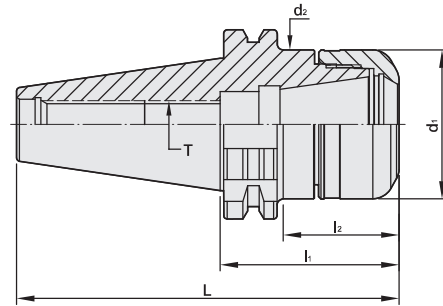

MODEL NO.	TYPE	L	l ₁	l ₂	d ₁	d ₂	T	SIZE RANGE	WEIGHT (KGS)
66.273.16.070	SDAT40 x PNER16 - 70	138.4	70	45.9	30	30	M10 x 1.5P	3 ~ 10	1.05
66.273.16.100	SDAT40 x PNER16 - 100	168.4	100	75.9	30	30	M10 x 1.5P	3 ~ 10	1.15
66.273.20.070	SDAT40 x PNER20 - 70	138.4	70	45.9	32	32	M12 x 1.75P	3 ~ 13	1.10
66.273.20.100	SDAT40 x PNER20 - 100	168.4	100	75.9	32	32	M12 x 1.75P	3 ~ 13	1.30
66.273.25.070	SDAT40 x PNER25 - 70	138.4	70	45.9	40	40	M16 x 2.0P	3 ~ 16	1.15
66.273.25.100	SDAT40 x PNER25 - 100	168.4	100	75.9	40	40	M16 x 2.0P	3 ~ 16	1.45
66.273.32.050	SDAT40 x PNER32 - 50	118.4	50	30.4	50	50	M16 x 2.0P	3 ~ 20	1.10
66.273.32.070	SDAT40 x PNER32 - 70	138.4	70	50.4	50	50	M16 x 2.0P	3 ~ 20	1.22
66.273.32.100	SDAT40 x PNER32 - 100	168.4	100	80.4	50	50	M16 x 2.0P	3 ~ 20	1.62
66.273.40.100	SDAT40 x PNER40 - 100	168.4	100	80.4	63	63	M20 x 2.0P	6 ~ 26	1.65
67.273.16.070	SDAT50 x PNER16 - 70	171.75	70	40.9	30	30	M10 x 1.5P	3 ~ 10	2.80
67.273.16.100	SDAT50 x PNER16 - 100	201.75	100	70.9	30	30	M10 x 1.5P	3 ~ 10	3.20
67.273.16.160	SDAT50 x PNER16 - 160	261.75	160	130.9	30	30	M10 x 1.5P	3 ~ 10	4.50
67.273.20.070	SDAT50 x PNER20 - 70	171.75	70	40.9	32	32	M12 x 1.75P	3 ~ 13	3.00
67.273.20.100	SDAT50 x PNER20 - 100	201.75	100	70.9	32	32	M12 x 1.75P	3 ~ 13	3.40
67.273.25.070	SDAT50 x PNER25 - 70	171.75	70	40.9	40	40	M16 x 2.0P	3 ~ 16	3.40
67.273.25.100	SDAT50 x PNER25 - 100	201.75	100	70.9	40	40	M16 x 2.0P	3 ~ 16	3.54
67.273.25.160	SDAT50 x PNER25 - 160	261.75	160	130.9	40	40	M16 x 2.0P	3 ~ 16	4.60
67.273.32.070	SDAT50 x PNER32 - 70	171.75	70	40.9	50	50	M16 x 2.0P	3 ~ 20	3.50
67.273.32.100	SDAT50 x PNER32 - 100	201.75	100	70.9	50	50	M16 x 2.0P	3 ~ 20	4.30
67.273.40.070	SDAT50 x PNER40 - 70	171.75	70	45.9	63	63	M20 x 2.0P	6 ~ 26	3.50
67.273.40.100	SDAT50 x PNER40 - 100	201.75	100	75.9	63	63	M20 x 2.0P	6 ~ 26	4.30

Product information:

- ▶ Balance: G2.5 25,000 rpm. Higher balancing grade and revolution can be done upon request but additional charge is needed.
- ▶ AD+B type is available, please inform us when making an order.
- ▶ Use PN 3µm collet.

Standard Accessory: • NUT

Collet	Nut	Pull Stud	Preset Screw	Spanner
P.W-4	P.W-39	P.W-57	P.W-82	P.W-62~67



SDAT / UT COLLET CHUCK



SDAT / UT 法蘭加厚型立銑刀夾頭



T W PAT NO. M298033
 T W PAT NO. M311791
 J P PAT NO. 3128766
 K R PAT NO. 20-0433603
 C N PAT NO. ZL200620132661.0
 C H PAT NO. 696550
 T R PAT NO. TR 2007 02942 Y
 I T PAT NO. N.0000266731

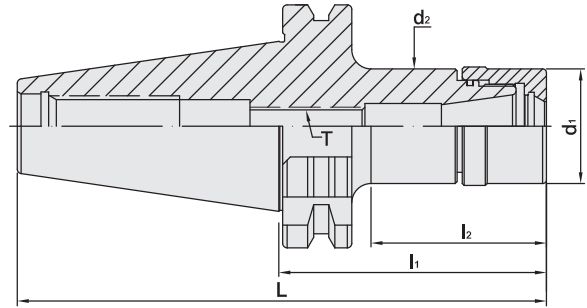

MODEL NO.	TYPE	L	l ₁	l ₂	d ₁	d ₂	T	SIZE RANGE	WEIGHT (KGS)
66.753.16.070	SDAT40 x UT16 - 70	138.4	70	45.9	30	30	M10 x 1.5P	1 ~ 10	1.03
66.753.16.100	SDAT40 x UT16 - 100	168.4	100	75.9	30	30	M10 x 1.5P	1 ~ 10	1.16
66.753.16.125	SDAT40 x UT16 - 125	193.4	125	100.9	30	30	M10 x 1.5P	1 ~ 10	1.27
66.753.16.150	SDAT40 x UT16 - 150	218.4	150	125.9	30	30	M10 x 1.5P	1 ~ 10	1.37
66.753.20.070	SDAT40 x UT20 - 70	138.4	70	45.9	35	36	M12 x 1.75P	1 ~ 13	1.10
66.753.20.100	SDAT40 x UT20 - 100	168.4	100	75.9	35	36	M12 x 1.75P	1 ~ 13	1.30
66.753.20.125	SDAT40 x UT20 - 125	193.4	125	100.9	35	36	M12 x 1.75P	1 ~ 13	1.46
66.753.20.150	SDAT40 x UT20 - 150	218.4	150	125.9	35	36	M12 x 1.75P	1 ~ 13	1.63
66.753.25.070	SDAT40 x UT25 - 70	138.4	70	45.9	42	42	M16 x 2.0P	1 ~ 16	1.16
66.753.25.100	SDAT40 x UT25 - 100	168.4	100	75.9	42	42	M16 x 2.0P	1 ~ 16	1.45
66.753.25.150	SDAT40 x UT25 - 150	218.4	150	125.9	42	42	M16 x 2.0P	1 ~ 16	1.92
66.753.32.070	SDAT40 x UT32 - 70	138.4	70	50.1	48	48	M16 x 2.0P	2 ~ 20	1.19
66.753.32.100	SDAT40 x UT32 - 100	168.4	100	80.1	48	48	M16 x 2.0P	2 ~ 20	1.58
66.753.32.125	SDAT40 x UT32 - 125	193.4	125	105.1	48	48	M16 x 2.0P	2 ~ 20	1.89
66.753.32.150	SDAT40 x UT32 - 150	218.4	150	130.1	48	48	M16 x 2.0P	2 ~ 20	2.21

Product information:

- ▶ The pre-balance reaches G6.3 10,000 rpm. Higher balancing grade and revolution can be done upon request but additional charge is needed.
- ▶ AD+B type is available, please inform us when making an order.
- ▶ Use standard ER collets.

Standard Accessory: • NUT

Collet	Nut	Pull Stud	Preset Screw	Spanner
P.W-6~9	P.W-41	P.W-57	P.W-82	P.W-62~67

SDAT / UT COLLET CHUCK



SDAT / UT 法蘭加厚型立銑刀夾頭



T W PAT NO. M298033
 T W PAT NO. M311791
 J P PAT NO. 3128766
 K R PAT NO. 20-0433603
 C N PAT NO. ZL200620132661.0
 C H PAT NO. 696550
 T R PAT NO. TR 2007 02942 Y
 I T PAT NO. N.0000266731

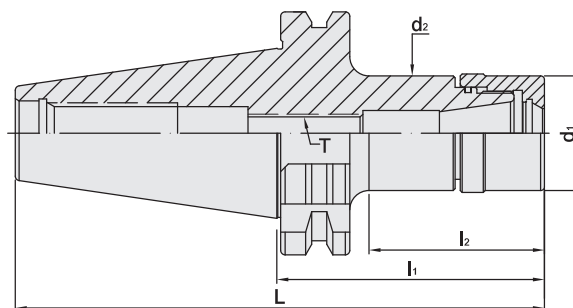

MODEL NO.	TYPE	L	l ₁	l ₂	d ₁	d ₂	T	SIZE RANGE	WEIGHT (KGS)
67.753.16.070	SDAT50 x UT16 - 70	171.75	70	45.9	30	30	M10 x 1.5P	1 ~ 10	2.79
67.753.16.100	SDAT50 x UT16 - 100	201.75	100	75.9	30	30	M10 x 1.5P	1 ~ 10	2.94
67.753.16.125	SDAT50 x UT16 - 125	226.75	125	95.9	30	30	M10 x 1.5P	1 ~ 10	3.01
67.753.16.150	SDAT50 x UT16 - 150	251.75	150	120.9	30	30	M10 x 1.5P	1 ~ 10	3.12
67.753.20.070	SDAT50 x UT20 - 70	171.75	70	40.9	35	36	M12 x 1.75P	1 ~ 13	2.89
67.753.20.100	SDAT50 x UT20 - 100	201.75	100	70.9	35	36	M12 x 1.75P	1 ~ 13	3.05
67.753.20.125	SDAT50 x UT20 - 125	226.75	125	95.9	35	36	M12 x 1.75P	1 ~ 13	3.18
67.753.20.150	SDAT50 x UT20 - 150	251.75	150	120.9	35	36	M12 x 1.75P	1 ~ 13	3.31
67.753.25.070	SDAT50 x UT25 - 70	171.75	70	45.9	42	42	M16 x 2.0P	1 ~ 16	2.94
67.753.25.100	SDAT50 x UT25 - 100	201.75	100	70.9	42	42	M16 x 2.0P	1 ~ 16	3.21
67.753.25.150	SDAT50 x UT25 - 150	251.75	150	120.9	42	42	M16 x 2.0P	1 ~ 16	3.72
67.753.32.070	SDAT50 x UT32 - 70	171.75	70	45.9	48	48	M16 x 2.0P	2 ~ 20	2.98
67.753.32.100	SDAT50 x UT32 - 100	201.75	100	70.9	48	48	M16 x 2.0P	2 ~ 20	3.36
67.753.32.125	SDAT50 x UT32 - 125	226.75	125	95.9	48	48	M16 x 2.0P	2 ~ 20	3.64
67.753.32.150	SDAT50 x UT32 - 150	251.75	150	120.9	48	48	M16 x 2.0P	2 ~ 20	3.92

Product information:

- ▶ The pre-balance reaches G6.3 10,000 rpm. Higher balancing grade and revolution can be done upon request but additional charge is needed.
- ▶ AD+B type is available, please inform us when making an order.
- ▶ Use standard ER collets.

Standard Accessory: • NUT

Collet	Nut	Pull Stud	Preset Screw	Spanner
P.W-6~9	P.W-41	P.W-57	P.W-82	P.W-62~67



SDAT / ER COLLET CHUCK



SDAT / ER 法蘭加厚型立銑刀夾頭



T W PAT NO. M298033
 T W PAT NO. M311791
 J P PAT NO. 3128766
 K R PAT NO. 20-0433603
 C N PAT NO. ZL200620132661.0
 C H PAT NO. 696550
 T R PAT NO. TR 2007 02942 Y
 I T PAT NO. N.0000266731

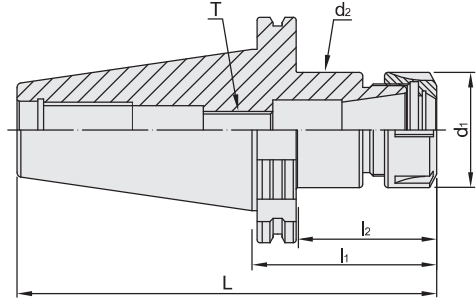

MODEL NO.	TYPE	L	l ₁	l ₂	d ₁	d ₂	T	SIZE RANGE	WEIGHT (KGS)
66.122.11.080	SDAT40 x ER11A - 80	148.4	80	50	19	19	M6 x 1.0P	1 ~ 7	1.05
66.122.11.125	SDAT40 x ER11A - 125	193.4	125	95	19	19	M6 x 1.0P	1 ~ 7	1.15
66.122.16.070	SDAT40 x ER16A - 70	138.4	70	40	28	28	M10 x 1.5P	1 ~ 10	1.10
66.122.16.100	SDAT40 x ER16A - 100	168.4	100	70	28	28	M10 x 1.5P	1 ~ 10	1.20
66.122.16.125	SDAT40 x ER16A - 125	193.4	125	95	28	28	M10 x 1.5P	1 ~ 10	1.30
66.122.16.150	SDAT40 x ER16A - 150	218.4	150	120	28	28	M10 x 1.5P	1 ~ 10	1.38
66.122.16.180	SDAT40 x ER16A - 180	248.4	180	150	28	28	M10 x 1.5P	1 ~ 10	1.85
66.122.20.070	SDAT40 x ER20A - 70	138.4	70	47	34	34	M12 x 1.75P	1 ~ 13	1.10
66.122.20.100	SDAT40 x ER20A - 100	168.4	100	70	34	34	M12 x 1.75P	1 ~ 13	1.30
66.122.20.135	SDAT40 x ER20A - 135	203.4	135	105	34	34	M12 x 1.75P	1 ~ 13	1.95
66.122.20.160	SDAT40 x ER20A - 160	228.4	160	130	34	34	M12 x 1.75P	1 ~ 13	2.20
66.122.25.070	SDAT40 x ER25 - 70	138.4	70	50	42	42	M16 x 2.0P	1 ~ 16	1.20
66.122.25.100	SDAT40 x ER25 - 100	168.4	100	80	42	42	M16 x 2.0P	1 ~ 16	1.45
66.122.25.150	SDAT40 x ER25 - 150	218.4	150	130	42	42	M16 x 2.0P	1 ~ 16	2.25
66.122.25.180	SDAT40 x ER25 - 180	248.4	180	160	42	42	M16 x 2.0P	1 ~ 16	2.45
66.122.25.200	SDAT40 x ER25 - 200	268.4	200	180	42	42	M16 x 2.0P	1 ~ 16	2.00
66.122.32.070	SDAT40 x ER32 - 70	138.4	70	50	50	49.7	M16 x 2.0P	2 ~ 20	1.30
66.122.32.100	SDAT40 x ER32 - 100	168.4	100	80	50	49.5	M16 x 2.0P	2 ~ 20	1.65
66.122.32.135	SDAT40 x ER32 - 135	203.4	135	115	50	49.7	M16 x 2.0P	2 ~ 20	2.15
66.122.32.150	SDAT40 x ER32 - 150	218.4	150	130	50	49.7	M16 x 2.0P	2 ~ 20	2.65
66.122.40.070	SDAT40 x ER40 - 70	138.4	70	50	63	50	M20 x 2.0P	3 ~ 26	1.50
66.122.40.100	SDAT40 x ER40 - 100	168.4	100	80	63	50	M20 x 2.0P	3 ~ 26	2.00
66.122.40.135	SDAT40 x ER40 - 135	203.4	135	115	63	50	M20 x 2.0P	3 ~ 26	2.30
66.122.50.100	SDAT40 x ER50 - 100	168.4	100	80	78	64	M24 x 2.0P	5 ~ 34	1.70

Product information:

- ▶ The pre-balance reaches G6.3 10,000 rpm. Higher balancing grade and revolution can be done upon request but additional charge is needed.
- ▶ AD+B type is available, please inform us when making an order.

Standard Accessory: • NUT

Collet	Nut	Pull Stud	Preset Screw	Spanner
P.W-6~24	P.W-42	P.W-57	P.W-82	P.W-62~65

SDAT / ER COLLET CHUCK



SDAT / ER 法蘭加厚型立銑刀夾頭



T W PAT NO. M298033
 T W PAT NO. M311791
 J P PAT NO. 3128766
 K R PAT NO. 20-0433603
 C N PAT NO. ZL200620132661.0
 C H PAT NO. 696550
 T R PAT NO. TR 2007 02942 Y
 I T PAT NO. N.0000266731

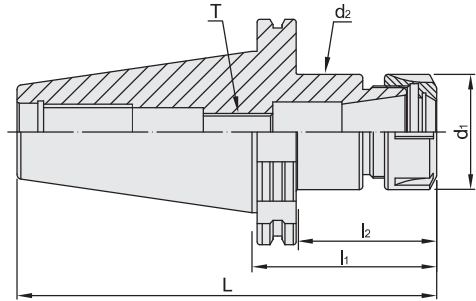

MODEL NO.	TYPE	L	l ₁	l ₂	d ₁	d ₂	T	SIZE RANGE	WEIGHT (KGS)
67.122.16.100	SDAT50 x ER16A - 100	201.75	100	70	28	28	M10 x 1.5P	1 ~ 10	3.20
67.122.16.135	SDAT50 x ER16A - 135	236.75	135	105	28	28	M10 x 1.5P	1 ~ 10	4.30
67.122.16.160	SDAT50 x ER16A - 160	261.75	160	130	28	28	M10 x 1.5P	1 ~ 10	4.50
67.122.16.180	SDAT50 x ER16A - 180	281.75	180	150	28	28	M10 x 1.5P	1 ~ 10	4.80
67.122.20.100	SDAT50 x ER20A - 100	201.75	100	70	34	34	M12 x 1.75P	1 ~ 13	3.40
67.122.20.135	SDAT50 x ER20A - 135	236.75	135	105	34	34	M12 x 1.75P	1 ~ 13	3.60
67.122.20.160	SDAT50 x ER20A - 160	261.75	160	130	34	34	M12 x 1.75P	1 ~ 13	3.80
67.122.25.070	SDAT50 x ER25 - 70	171.75	70	40	42	42	M16 x 2.0P	1 ~ 16	3.40
67.122.25.100	SDAT50 x ER25 - 100	201.75	100	70	42	42	M16 x 2.0P	1 ~ 16	3.54
67.122.25.150	SDAT50 x ER25 - 150	251.75	150	120	42	42	M16 x 2.0P	1 ~ 16	4.50
67.122.25.200	SDAT50 x ER25 - 200	301.75	200	170	42	42	M16 x 2.0P	1 ~ 16	4.70
67.122.32.080	SDAT50 x ER32 - 80	181.75	80	50	50	50	M20 x 2.0P	2 ~ 20	3.60
67.122.32.120	SDAT50 x ER32 - 120	221.75	120	90	50	50	M20 x 2.0P	2 ~ 20	4.60
67.122.32.160	SDAT50 x ER32 - 160	261.75	160	130	50	50	M20 x 2.0P	2 ~ 20	4.60
67.122.32.200	SDAT50 x ER32 - 200	301.75	200	170	50	50	M20 x 2.0P	2 ~ 20	5.20
67.122.40.080	SDAT50 x ER40 - 80	181.75	80	50	63	60	M20 x 2.0P	3 ~ 26	3.65
67.122.40.120	SDAT50 x ER40 - 120	221.75	120	90	63	60	M20 x 2.0P	3 ~ 26	4.50
67.122.40.160	SDAT50 x ER40 - 160	261.75	160	130	63	60	M20 x 2.0P	3 ~ 26	5.20
67.122.40.200	SDAT50 x ER40 - 200	301.75	200	170	63	60	M20 x 2.0P	3 ~ 26	5.40
67.122.50.080	SDAT50 x ER50 - 80	181.75	80	57	78	60	M24 x 2.0P	5 ~ 34	4.85
67.122.50.120	SDAT50 x ER50 - 120	221.75	120	99	78	78	M24 x 2.0P	5 ~ 34	5.45
67.122.50.160	SDAT50 x ER50 - 160	261.75	160	139	78	78	M24 x 2.0P	5 ~ 34	5.55
67.122.50.200	SDAT50 x ER50 - 200	301.75	200	179	78	78	M24 x 2.0P	5 ~ 34	5.70

Product information:

- ▶ The pre-balance reaches G6.3 10,000 rpm. Higher balancing grade and revolution can be done upon request but additional charge is needed.
- ▶ AD+B type is available, please inform us when making an order.

Standard Accessory: • NUT

Collet	Nut	Pull Stud	Preset Screw	Spanner
P.W-6~24	P.W-42	P.W-57	P.W-82	P.W-62~65



SDAT / ER COLLET CHUCK

M TYPE



M 型 SDAT / ER 法蘭加厚型立銑刀夾頭

(DIN ISO 15488)



T W PAT NO. M298033
 T W PAT NO. M311791
 J P PAT NO. 3128766
 K R PAT NO. 20-0433603
 C N PAT NO. ZL200620132661.0
 C H PAT NO. 696550
 T R PAT NO. TR 2007 02942 Y
 I T PAT NO. N.0000266731

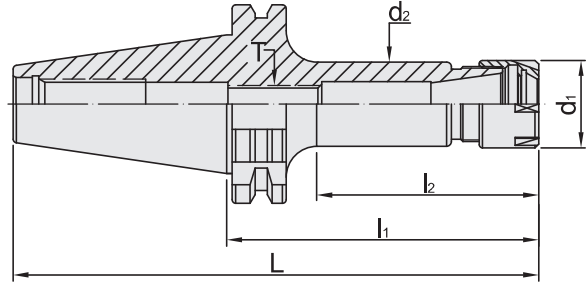

MODEL NO.	TYPE	L	l ₁	l ₂	d ₁	d ₂	T	SIZE RANGE	WEIGHT (KGS)
66.123.11.070	SDAT40 x ER11M - 70	138.4	70	40	16	15	M6 x 1.0P	1 ~ 7	1.10
66.123.11.100	SDAT40 x ER11M - 100	168.4	100	70	16	15	M6 x 1.0P	1 ~ 7	1.20
66.123.11.125	SDAT40 x ER11M - 125	193.4	125	95	16	15	M6 x 1.0P	1 ~ 7	1.40
66.123.11.150	SDAT40 x ER11M - 150	218.4	150	120	16	15	M6 x 1.0P	1 ~ 7	1.50
66.123.16.070	SDAT40 x ER16M - 70	138.4	70	40	22	21	M10 x 1.5P	1 ~ 10	1.20
66.123.16.100	SDAT40 x ER16M - 100	168.4	100	70	22	21	M10 x 1.5P	1 ~ 10	1.30
66.123.16.125	SDAT40 x ER16M - 125	193.4	125	95	22	21	M10 x 1.5P	1 ~ 10	1.50
66.123.16.150	SDAT40 x ER16M - 150	218.4	150	120	22	21	M10 x 1.5P	1 ~ 10	1.60
66.123.20.070	SDAT40 x ER20M - 70	138.4	70	40	28	27	M12 x 1.75P	1 ~ 13	1.20
66.123.20.100	SDAT40 x ER20M - 100	168.4	100	70	28	27	M12 x 1.75P	1 ~ 13	1.55
66.123.20.125	SDAT40 x ER20M - 125	193.4	125	95	28	27	M12 x 1.75P	1 ~ 13	1.70
66.123.20.150	SDAT40 x ER20M - 150	218.4	150	120	28	27	M12 x 1.75P	1 ~ 13	1.80
67.123.11.070	SDAT50 x ER11M - 70	171.75	70	40	16	15	M6 x 1.0P	1 ~ 7	3.80
67.123.11.090	SDAT50 x ER11M - 90	191.75	90	60	16	15	M6 x 1.0P	1 ~ 7	3.90
67.123.11.105	SDAT50 x ER11M - 105	206.75	105	56	16	15	M6 x 1.0P	1 ~ 7	4.00
67.123.11.135	SDAT50 x ER11M - 135	236.75	135	86	16	15	M6 x 1.0P	1 ~ 7	4.10
67.123.11.165	SDAT50 x ER11M - 165	266.75	165	98	16	15	M6 x 1.0P	1 ~ 7	4.20
67.123.16.070	SDAT50 x ER16M - 70	171.75	70	40	22	21	M10 x 1.5P	1 ~ 10	3.90
67.123.16.090	SDAT50 x ER16M - 90	191.75	90	60	22	21	M10 x 1.5P	1 ~ 10	4.00
67.123.16.105	SDAT50 x ER16M - 105	206.75	105	68	22	21	M10 x 1.5P	1 ~ 10	4.10
67.123.16.135	SDAT50 x ER16M - 135	236.75	135	98	22	21	M10 x 1.5P	1 ~ 10	4.20
67.123.16.165	SDAT50 x ER16M - 165	266.75	165	128	22	21	M10 x 1.5P	1 ~ 10	4.30
67.123.20.090	SDAT50 x ER20M - 90	191.75	90	60	28	27	M12 x 1.75P	1 ~ 13	4.10
67.123.20.105	SDAT50 x ER20M - 105	206.75	105	71	28	27	M12 x 1.75P	1 ~ 13	4.20
67.123.20.135	SDAT50 x ER20M - 135	236.75	135	101	28	27	M12 x 1.75P	1 ~ 13	4.40
67.123.20.165	SDAT50 x ER20M - 165	266.75	165	131	28	27	M12 x 1.75P	1 ~ 13	4.60

Product information:

- ▶ The pre-balance reaches G6.3 10,000 rpm. Higher balancing grade and revolution can be done upon request but additional charge is needed.
- ▶ AD+B type is available, please inform us when making an order.

Standard Accessory: • NUT

Collet	Nut	Pull Stud	Preset Screw	Spanner
P.W-6~24	P.W-43	P.W-57	P.W-82	P.W-62~65

SDAT / SKX COLLET CHUCK



SDAT / SKX 法蘭加厚型立銑刀夾頭



Fig.1

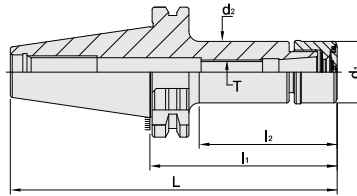
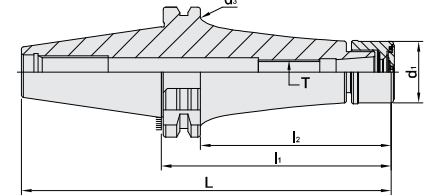

Fig.2



MODEL NO.	TYPE	L	l ₁	l ₂	d ₁	d ₂	d ₃	T	SIZE RANGE	Fig.	WEIGHT (KGS)
66.790.06.060	SDAT40 x SKX6 - 60	128.4	60	30	18	18	-	M8 x 1.25P	3 ~ 6	1	1.00
66.790.06.090	SDAT40 x SKX6 - 90	158.4	90	51	18	18	-	M8 x 1.25P	3 ~ 6	1	1.10
66.790.06.120	SDAT40 x SKX6 - 120	188.4	120	81	18	18	53	M8 x 1.25P	3 ~ 6	2	1.40
66.790.06.150	SDAT40 x SKX6 - 150	218.4	150	111	18	18	53	M8 x 1.25P	3 ~ 6	2	1.50
66.790.10.060	SDAT40 x SKX10 - 60	128.4	60	32	30	30	-	M12 x 1.75P	3 ~ 10	1	1.10
66.790.10.090	SDAT40 x SKX10 - 90	158.4	90	48	30	30	-	M12 x 1.75P	3 ~ 10	1	1.20
66.790.10.120	SDAT40 x SKX10 - 120	188.4	120	78	30	30	53	M12 x 1.75P	3 ~ 10	2	1.40
66.790.10.150	SDAT40 x SKX10 - 150	218.4	150	108	30	30	53	M12 x 1.75P	3 ~ 10	2	1.60
66.790.10.180	SDAT40 x SKX10 - 180	248.4	180	138	30	30	53	M12 x 1.75P	3 ~ 10	2	1.60
66.790.16.060	SDAT40 x SKX16 - 60	128.4	60	32	40	40	-	M18 x 1.5P	3 ~ 16	1	1.30
66.790.16.090	SDAT40 x SKX16 - 90	158.4	90	58	40	40	-	M18 x 1.5P	3 ~ 16	1	1.50
66.790.16.120	SDAT40 x SKX16 - 120	188.4	120	88	40	40	80	M18 x 1.5P	3 ~ 16	2	1.70
66.790.16.150	SDAT40 x SKX16 - 150	218.4	150	118	40	40	80	M18 x 1.5P	3 ~ 16	2	1.90
66.790.16.180	SDAT40 x SKX16 - 180	248.4	180	148	40	40	80	M18 x 1.5P	3 ~ 16	2	2.00
66.790.20.090	SDAT40 x SKX20 - 90	158.4	90	60	48.5	48.5	-	M22 x 1.5P	3 ~ 20	1	1.60
66.790.20.120	SDAT40 x SKX20 - 120	188.4	120	89.9	48.5	48.5	80	M22 x 1.5P	3 ~ 20	2	2.00
66.790.25.090	SDAT40 x SKX25 - 90	158.4	90	61	55	55	-	M28 x 2.0P	3 ~ 25.4	1	1.80
66.790.25.120	SDAT40 x SKX25 - 120	188.4	120	91	55	55	80	M28 x 2.0P	3 ~ 25.4	2	2.00

Features:

- ▶ SKX sealed cap is optional. Please order SKX sealed cap additionally.
- ▶ With the design of SKX sealed cap, coolant pressure capable up to 70 bar.
- ▶ Used with coolant-through tools.
- ▶ Balance: G2.5 25,000rpm.

Standard Accessory: • NUT

Collet	Nut	Cap	Pull Stud	Preset Screw	Spanner	Sealed Cap Spanner
P.W-25	P.W-49	P.W-50	P.W-57	P.W-82	P.W-62~67	P.W-66



SDAT / SKX COLLET CHUCK



SDAT / SKX 法蘭加厚型立銑刀夾頭



Fig.1

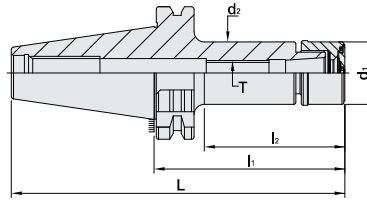
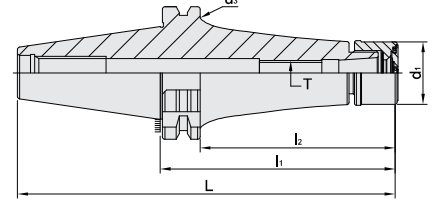

Fig.2



MODEL NO.	TYPE	L	l ₁	l ₂	d ₁	d ₂	d ₃	T	SIZE RANGE	Fig.	WEIGHT (KGS)
67.790.06.105	SDAT50 x SKX6 - 105	206.8	105	55	18	18	-	M8 x 1.25P	3 ~ 6	1	3.80
67.790.06.135	SDAT50 x SKX6 - 135	236.8	135	60	18	18	-	M8 x 1.25P	3 ~ 6	1	3.90
67.790.06.165	SDAT50 x SKX6 - 165	266.8	165	85	18	18	-	M8 x 1.25P	3 ~ 6	1	4.00
67.790.06.200	SDAT50 x SKX6 - 200	301.8	200	120	18	18	80	M8 x 1.25P	3 ~ 6	2	4.20
67.790.10.105	SDAT50 x SKX10 - 105	206.8	105	57	30	30	-	M12 x 1.75P	3 ~ 10	1	4.20
67.790.10.135	SDAT50 x SKX10 - 135	236.8	135	70	30	30	-	M12 x 1.75P	3 ~ 10	1	4.40
67.790.10.165	SDAT50 x SKX10 - 165	266.8	165	90	30	30	-	M12 x 1.75P	3 ~ 10	1	4.60
67.790.10.200	SDAT50 x SKX10 - 200	301.8	200	125	30	30	80	M12 x 1.75P	3 ~ 10	2	4.80
67.790.16.105	SDAT50 x SKX16 - 105	206.8	105	62	40	40	-	M18 x 1.5P	3 ~ 16	1	4.70
67.790.16.135	SDAT50 x SKX16 - 135	236.8	135	92	40	40	-	M18 x 1.5P	3 ~ 16	1	4.90
67.790.16.165	SDAT50 x SKX16 - 165	266.8	165	90	40	40	-	M18 x 1.5P	3 ~ 16	1	5.10
67.790.16.200	SDAT50 x SKX16 - 200	301.8	200	125	40	40	80	M18 x 1.5P	3 ~ 16	2	5.50
67.790.20.105	SDAT50 x SKX20 - 105	206.8	105	62	48.5	48.5	-	M22 x 1.5P	3 ~ 20	1	4.30
67.790.20.135	SDAT50 x SKX20 - 135	236.8	135	92	48.5	48.5	-	M22 x 1.5P	3 ~ 20	1	4.60
67.790.20.165	SDAT50 x SKX20 - 165	266.8	165	122	48.5	48.5	-	M22 x 1.5P	3 ~ 20	1	5.00
67.790.25.105	SDAT50 x SKX25 - 105	206.8	105	62	55	55	-	M28 x 2.0P	3 ~ 25.4	1	5.20
67.790.25.135	SDAT50 x SKX25 - 135	236.8	135	92	55	55	-	M28 x 2.0P	3 ~ 25.4	1	5.40
67.790.25.165	SDAT50 x SKX25 - 165	266.8	165	122	55	55	-	M28 x 2.0P	3 ~ 25.4	1	5.60
67.790.25.200	SDAT50 x SKX25 - 200	301.8	200	157	55	55	80	M28 x 2.0P	3 ~ 25.4	2	6.00

Features:

- ▶ SKX sealed cap is optional. Please order SKX sealed cap additionally.
- ▶ With the design of SKX sealed cap, coolant pressure capable up to 70 bar.
- ▶ Used with coolant-through tools.
- ▶ Balance: G2.5 25,000rpm.

Standard Accessory: • NUT

Collet	Nut	Cap	Pull Stud	Preset Screw	Spanner	Sealed Cap Spanner
P.W-25	P.W-49	P.W-50	P.W-57	P.W-82	P.W-62~67	P.W-66

SDAT / SK3 COLLET CHUCK



SDAT / SK3 法蘭加厚型高速機專用夾頭

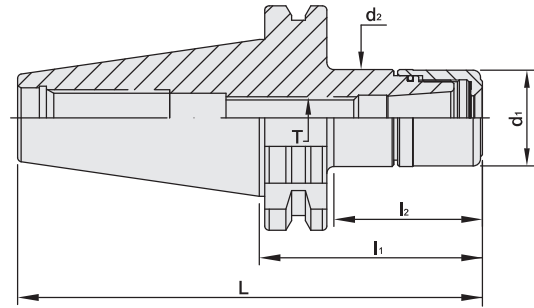

MODEL NO.	TYPE	L	l ₁	l ₂	d ₁	d ₂	T	SIZE RANGE	WEIGHT (KGS)
66.763.06.080	SDAT40 x SK306 - 80	148.4	80	42.75	19.5	19.5	M8 x 1.25P	3 ~ 6	1.10
66.763.06.100	SDAT40 x SK306 - 100	168.4	100	62.75	19.5	19.5	M8 x 1.25P	3 ~ 6	1.30
66.763.06.120	SDAT40 x SK306 - 120	188.4	120	82.75	19.5	19.5	M8 x 1.25P	3 ~ 6	1.40
66.763.10.080	SDAT40 x SK310 - 80	148.4	80	50.9	27.5	27.5	M12 x 1.75P	3 ~ 10	1.10
66.763.10.100	SDAT40 x SK310 - 100	168.4	100	70.9	27.5	27.5	M12 x 1.75P	3 ~ 10	1.30
66.763.10.120	SDAT40 x SK310 - 120	188.4	120	90.9	27.5	27.5	M12 x 1.75P	3 ~ 10	1.40
66.763.13.080	SDAT40 x SK313 - 80	148.4	80	55.9	33	33	M12 x 1.75P	3 ~ 13	1.10
66.763.13.100	SDAT40 x SK313 - 100	168.4	100	75.9	33	33	M12 x 1.75P	3 ~ 13	1.30
66.763.13.120	SDAT40 x SK313 - 120	188.4	120	95.9	33	33	M12 x 1.75P	3 ~ 13	1.40
66.763.16.080	SDAT40 x SK316 - 80	148.4	80	55.9	40	40	M18 x 1.5P	3 ~ 16	1.20
66.763.16.100	SDAT40 x SK316 - 100	168.4	100	75.9	40	40	M18 x 1.5P	3 ~ 16	1.40
66.763.16.120	SDAT40 x SK316 - 120	188.4	120	95.9	40	40	M18 x 1.5P	3 ~ 16	1.50
67.763.06.080	SDAT50 x SK306 - 80	181.75	80	40.75	19.5	19.5	M8 x 1.25P	3 ~ 6	4.00
67.763.06.100	SDAT50 x SK306 - 100	201.75	100	60.75	19.5	19.5	M8 x 1.25P	3 ~ 6	4.10
67.763.06.120	SDAT50 x SK306 - 120	221.75	120	80.75	19.5	19.5	M8 x 1.25P	3 ~ 6	4.20
67.763.10.080	SDAT50 x SK310 - 80	181.75	80	50.9	27.5	27.5	M12 x 1.75P	3 ~ 10	4.10
67.763.10.100	SDAT50 x SK310 - 100	201.75	100	70.9	27.5	27.5	M12 x 1.75P	3 ~ 10	4.20
67.763.10.120	SDAT50 x SK310 - 120	221.75	120	90.9	27.5	27.5	M12 x 1.75P	3 ~ 10	4.30
67.763.13.080	SDAT50 x SK313 - 80	181.75	80	50.9	33	33	M12 x 1.75P	3 ~ 13	4.20
67.763.13.100	SDAT50 x SK313 - 100	201.75	100	70.9	33	33	M12 x 1.75P	3 ~ 13	4.30
67.763.13.120	SDAT50 x SK313 - 120	221.75	120	90.9	33	33	M12 x 1.75P	3 ~ 13	4.40
67.763.16.080	SDAT50 x SK316 - 80	181.75	80	50.9	40	40	M18 x 1.5P	3 ~ 16	4.30
67.763.16.100	SDAT50 x SK316 - 100	201.75	100	70.9	40	40	M18 x 1.5P	3 ~ 16	4.40
67.763.16.120	SDAT50 x SK316 - 120	221.75	120	90.9	40	40	M18 x 1.5P	3 ~ 16	4.50

Product information:

- ▶ Balance: G2.5 25,000 rpm. Higher balancing grade and revolution can be done upon request but additional charge is needed.
- ▶ AD+B type is available, please inform us when making an order.

Standard Accessory: • NUT

Collet	Nut	Pull Stud	Preset Screw	Spanner
P.W-25~28	P.W-46	P.W-57	P.W-82	P.W-62~67



SDAT / SKS COLLET CHUCK



SDAT / SKS 法蘭加厚型高速機專用夾頭

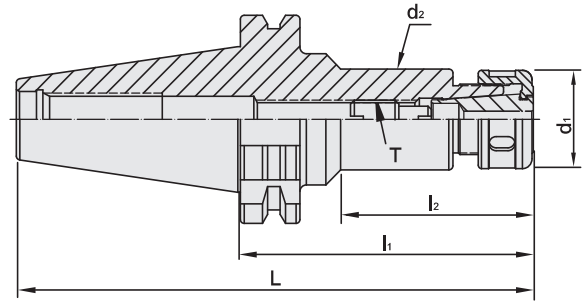

T W PAT NO. M270871

MODEL NO.	TYPE	L	l ₁	l ₂	d ₁	d ₂	T	SIZE RANGE	WEIGHT (KGS)
66.658.06.090	SDAT40 x SKS6 - 90	158.4	90	51	18	18	M8 x 1.25P	3 ~ 6	0.60
66.658.06.120	SDAT40 x SKS6 - 120	188.4	120	81	18	18	M8 x 1.25P	3 ~ 6	0.70
66.658.10.090	SDAT40 x SKS10 - 90	158.4	90	52	30	27.6	M12 x 1.75P	3 ~ 10	1.20
66.658.10.120	SDAT40 x SKS10 - 120	188.4	120	82	30	27.6	M12 x 1.75P	3 ~ 10	1.40
66.658.13.090	SDAT40 x SKS13 - 90	158.4	90	67	35	33	M12 x 1.75P	3 ~ 13	1.40
66.658.13.120	SDAT40 x SKS13 - 120	188.4	120	97	35	33	M12 x 1.75P	3 ~ 13	1.60
66.658.16.090	SDAT40 x SKS16 - 90	158.4	90	65	40	40	M18 x 1.5P	3 ~ 16	1.30
66.658.16.120	SDAT40 x SKS16 - 120	188.4	120	95	40	40	M18 x 1.5P	3 ~ 16	1.50
66.658.20.090	SDAT40 x SKS20 - 90	158.4	90	70	48.5	48.5	M22 x 1.5P	3 ~ 20	1.60
66.658.20.120	SDAT40 x SKS20 - 120	188.4	120	100	48.5	48.5	M22 x 1.5P	3 ~ 20	2.00
66.658.25.090	SDAT40 x SKS25 - 90	158.4	90	70	55	49.85	M28 x 2.0P	3 ~ 25.4	1.30
66.658.25.120	SDAT40 x SKS25 - 120	188.4	120	100	55	49.85	M28 x 2.0P	3 ~ 25.4	1.50
67.658.06.105	SDAT50 x SKS6 - 105	206.75	105	64	18	18	M8 x 1.25P	3 ~ 6	4.20
67.658.06.165	SDAT50 x SKS6 - 165	266.75	165	124	18	18	M8 x 1.25P	3 ~ 6	4.60
67.658.10.105	SDAT50 x SKS10 - 105	206.75	105	70	30	30	M12 x 1.75P	3 ~ 10	4.20
67.658.10.165	SDAT50 x SKS10 - 165	266.75	165	130	30	30	M12 x 1.75P	3 ~ 10	4.60
67.658.13.105	SDAT50 x SKS13 - 105	206.75	105	80	35	33	M12 x 1.75P	3 ~ 13	4.20
67.658.13.165	SDAT50 x SKS13 - 165	266.75	165	140	35	33	M12 x 1.75P	3 ~ 13	4.60
67.658.16.105	SDAT50 x SKS16 - 105	206.75	105	75	40	40	M18 x 1.5P	3 ~ 16	4.30
67.658.16.165	SDAT50 x SKS16 - 165	266.75	165	127	40	40	M18 x 1.5P	3 ~ 16	4.70
67.658.20.105	SDAT50 x SKS20 - 105	206.75	105	80	48.5	48.5	M22 x 1.5P	3 ~ 20	4.30
67.658.20.165	SDAT50 x SKS20 - 165	266.75	165	140	48.5	48.5	M22 x 1.5P	3 ~ 20	4.70
67.658.25.105	SDAT50 x SKS25 - 105	206.75	105	80	55	55	M28 x 2.0P	3 ~ 25.4	5.00
67.658.25.165	SDAT50 x SKS25 - 165	266.75	165	140	55	55	M28 x 2.0P	3 ~ 25.4	5.30

Product information:

- ▶ Balance: G2.5 25,000 rpm. Higher balancing grade and revolution can be done upon request but additional charge is needed.
- ▶ AD+B type is available, please inform us when making an order.

Standard Accessory: • NUT

Collet	Nut	Pull Stud	Preset Screw	Spanner
P.W-25~28	P.W-47~48	P.W-57	P.W-82	P.W-62~66

SDAT / SBL SLIM-FIT COLLET CHUCK



SDAT / SBL 法蘭加厚型後拉式立銑刀夾頭

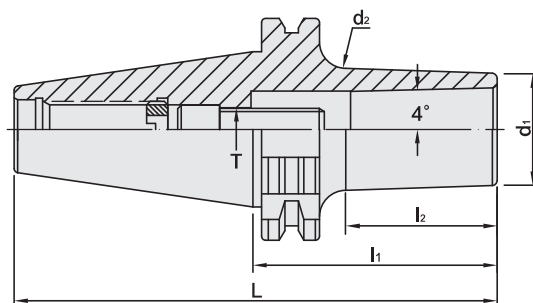

T W PAT NO. M274178

MODEL NO.	TYPE	L	l ₁	l ₂	d ₁	d ₂	T	TORQUE		SIZE RANGE	WEIGHT (KGS)
								N.m	1bf-ft		
66.648.06.070	SDAT40 x SBL6 - 70	138.4	70	36	14	17	M6 x 1.0P	12	9	3 ~ 6	1.00
66.648.06.100	SDAT40 x SBL6 - 100	168.4	100	58	14	20	M6 x 1.0P	12	9	3 ~ 6	1.10
66.648.08.100	SDAT40 x SBL8 - 100	168.4	100	71.4	20	27.4	M8 x 1.25P	29	21	3 ~ 8	1.25
66.648.08.130	SDAT40 x SBL8 - 130	198.4	130	101.4	20	30.6	M8 x 1.25P	29	21	3 ~ 8	1.19
66.648.08.150	SDAT40 x SBL8 - 150	218.4	150	121.4	20	32.6	M8 x 1.25P	29	21	3 ~ 8	1.32
66.648.12.070	SDAT40 x SBL12 - 70	138.4	70	41	26	29	M10 x 1.5P	45	33	3 ~ 12	1.20
66.648.12.100	SDAT40 x SBL12 - 100	168.4	100	73	26	32	M10 x 1.5P	45	33	3 ~ 12	1.30
66.648.20.070	SDAT40 x SBL20 - 70	138.4	70	46	35	39	M12 x 1.75P	60	44	3 ~ 20	1.30
66.648.20.100	SDAT40 x SBL20 - 100	168.4	100	78	35	41	M12 x 1.75P	60	44	3 ~ 20	1.40
66.648.25.080	SDAT40 x SBL25 - 80	148.4	80	58	40	45	M16 x 2.0P	90	66	3 ~ 25.4	1.50
66.648.25.100	SDAT40 x SBL25 - 100	168.4	100	79	40	46	M16 x 2.0P	90	66	3 ~ 25.4	1.60
67.648.06.070	SDAT50 x SBL6 - 70	171.75	70	36	14	17	M6 x 1.0P	12	9	3 ~ 6	2.80
67.648.06.100	SDAT50 x SBL6 - 100	201.75	100	66	14	20	M6 x 1.0P	12	9	3 ~ 6	2.90
67.648.08.100	SDAT50 x SBL8 - 100	201.75	100	71.4	20	27.4	M8 x 1.25P	29	21	3 ~ 8	2.81
67.648.08.130	SDAT50 x SBL8 - 130	231.75	130	101.4	20	30.6	M8 x 1.25P	29	21	3 ~ 8	2.98
67.648.08.150	SDAT50 x SBL8 - 150	281.75	150	121.4	20	32.7	M8 x 1.25P	29	21	3 ~ 8	3.11
67.648.12.070	SDAT50 x SBL12 - 70	171.75	70	41	26	29	M10 x 1.5P	45	33	3 ~ 12	3.00
67.648.12.100	SDAT50 x SBL12 - 100	201.75	100	73	26	32	M10 x 1.5P	45	33	3 ~ 12	3.10
67.648.20.070	SDAT50 x SBL20 - 70	171.75	70	41	35	38	M12 x 1.75P	60	44	3 ~ 20	3.20
67.648.20.100	SDAT50 x SBL20 - 100	201.75	100	76	35	41	M12 x 1.75P	60	44	3 ~ 20	3.30
67.648.25.080	SDAT50 x SBL25 - 80	181.75	80	58	40	45	M16 x 2.0P	90	66	3 ~ 25.4	3.20
67.648.25.100	SDAT50 x SBL25 - 100	201.75	100	78	40	46	M16 x 2.0P	90	66	3 ~ 25.4	3.40

Product information:

- ▶ Balance: G2.5 25,000 rpm. Higher balancing grade and revolution can be done upon request but additional charge is needed.
- ▶ AD+B type is available, please inform us when making an order.

Collet	Pull Stud	SCREW	Spanner
P.W-29	P.W-57	P.W-85	P.W-66



SDAT / SBLC SLIM-FIT COLLET CHUCK

Dual
DRIVE+

SDAT / SBLC 法蘭加厚型後拉式立銑刀夾頭

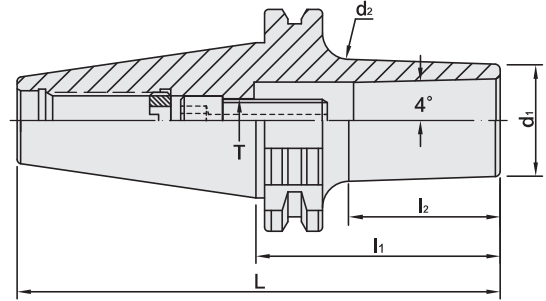

T W PAT NO. M274178

MODEL NO.	TYPE	L	l ₁	l ₂	d ₁	d ₂	T	TORQUE		SIZE RANGE	WEIGHT (KGS)
								N.m	1bf-ft		
66.648C.06.070	SDAT40 x SBLC6 - 70	138.4	70	36	14	17	M6 x 1.0P	12	9	3 ~ 6	1.00
66.648C.06.100	SDAT40 x SBLC6 - 100	168.4	100	58	14	20	M6 x 1.0P	12	9	3 ~ 6	1.10
66.648C.08.100	SDAT40 x SBLC8 - 100	168.4	100	71.4	20	27.4	M8 x 1.25P	29	21	3 ~ 8	1.25
66.648C.08.130	SDAT40 x SBLC8 - 130	198.4	130	101.4	20	30.6	M8 x 1.25P	29	21	3 ~ 8	1.19
66.648C.08.150	SDAT40 x SBLC8 - 150	218.4	150	121.4	20	32.6	M8 x 1.25P	29	21	3 ~ 8	1.32
66.648C.12.070	SDAT40 x SBLC12 - 70	138.4	70	41	26	29	M10 x 1.5P	45	33	3 ~ 12	1.20
66.648C.12.100	SDAT40 x SBLC12 - 100	168.4	100	73	26	32	M10 x 1.5P	45	33	3 ~ 12	1.30
66.648C.20.070	SDAT40 x SBLC20 - 70	138.4	70	46	35	39	M12 x 1.75P	60	44	3 ~ 20	1.30
66.648C.20.100	SDAT40 x SBLC20 - 100	168.4	100	78	35	41	M12 x 1.75P	60	44	3 ~ 20	1.40
66.648C.25.080	SDAT40 x SBLC25 - 80	148.4	80	58	40	45	M16 x 2.0P	90	66	3 ~ 25.4	1.50
66.648C.25.100	SDAT40 x SBLC25 - 100	168.4	100	79	40	46	M16 x 2.0P	90	66	3 ~ 25.4	1.60
67.648C.06.070	SDAT50 x SBLC6 - 70	171.75	70	36	14	17	M6 x 1.0P	12	9	3 ~ 6	2.80
67.648C.06.100	SDAT50 x SBLC6 - 100	201.75	100	66	14	20	M6 x 1.0P	12	9	3 ~ 6	2.90
67.648C.08.100	SDAT50 x SBLC8 - 100	201.75	100	71.4	20	27.4	M8 x 1.25P	29	21	3 ~ 8	2.81
67.648C.08.130	SDAT50 x SBLC8 - 130	231.75	130	101.4	20	30.6	M8 x 1.25P	29	21	3 ~ 8	2.98
67.648C.08.150	SDAT50 x SBLC8 - 150	281.75	150	121.4	20	32.7	M8 x 1.25P	29	21	3 ~ 8	3.11
67.648C.12.070	SDAT50 x SBLC12 - 70	171.75	70	41	26	29	M10 x 1.5P	45	33	3 ~ 12	3.00
67.648C.12.100	SDAT50 x SBLC12 - 100	201.75	100	73	26	32	M10 x 1.5P	45	33	3 ~ 12	3.10
67.648C.20.070	SDAT50 x SBLC20 - 70	171.75	70	41	35	38	M12 x 1.75P	60	44	3 ~ 20	3.20
67.648C.20.100	SDAT50 x SBLC20 - 100	201.75	100	76	35	41	M12 x 1.75P	60	44	3 ~ 20	3.30
67.648C.25.080	SDAT50 x SBLC25 - 80	181.75	80	58	40	45	M16 x 2.0P	90	66	3 ~ 25.4	3.20
67.648C.25.100	SDAT50 x SBLC25 - 100	201.75	100	78	40	46	M16 x 2.0P	90	66	3 ~ 25.4	3.40

Product information:

- ▶ Balance: G2.5 25,000 rpm. Higher balancing grade and revolution can be done upon request but additional charge is needed.
- ▶ AD+B type is available, please inform us when making an order.
- ▶ Used with SLC sealed collet and coolant through cutters.

Standard Accessory: • SPANNER

Collet	Pull Stud	SCREW	Spanner
			
P.W-30	P.W-57	P.W-85	P.W-66

SDAT / MLD MULTI - LOCK MILLING CHUCK



SDAT / MLD 法蘭加厚型直式筒夾 銑床夾頭



T W PAT NO. M447277
 T W PAT NO. M430337
 T W PAT NO. M451185
 C N PAT NO. ZL201220749784.4
 C H PAT NO. ZL201220749942.6

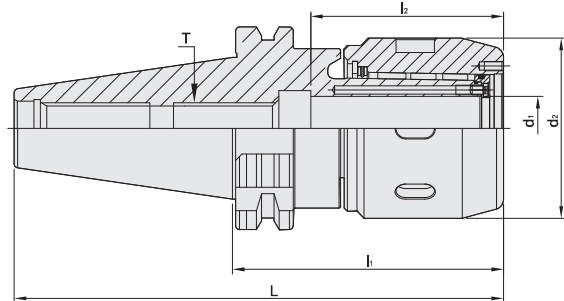

MODEL NO.	TYPE	L	l ₁	l ₂	d ₁	d ₂	T	WEIGHT (KGS)
66.463G.12.075	SDAT40 x MLD12 - 75	143.4	75	46.7	12	42	M12 x 1.75P	2.10
66.463G.16.080	SDAT40 x MLD16 - 80	148.4	80	56.7	16	48	M12 x 1.75P	2.20
66.463G.20.085	SDAT40 x MLD20 - 85	153.4	85	59.3	20	56.5	M16 x 2.0P	2.40
66.463G.20.135	SDAT40 x MLD20 - 135	203.4	135	59.3	20	56.5	M16 x 2.0P	2.50
66.463G.25.095	SDAT40 x MLD25 - 95	163.4	95	58.2	25	60	M16 x 2.0P	2.00
66.463G.32.105	SDAT40 x MLD32 - 105	173.4	105	71.7	32	71	M16 x 2.0P	2.70
66.463G.32.135	SDAT40 x MLD32 - 135	203.4	135	71.7	32	71	M16 x 2.0P	3.00
67.463G.12.075	SDAT50 x MLD12 - 75	176.75	75	46.7	12	42	M12 x 1.75P	3.20
67.463G.16.075	SDAT50 x MLD16 - 75	176.75	75	56.7	16	48	M12 x 1.75P	3.20
67.463G.20.105	SDAT50 x MLD20 - 105	206.75	105	59.3	20	56.5	M16 x 2.0P	4.50
67.463G.20.150	SDAT50 x MLD20 - 150	251.75	150	59.3	20	56.5	M16 x 2.0P	4.90
67.463G.25.105	SDAT50 x MLD25 - 105	206.75	105	58.2	25	60	M24 x 3.0P	4.10
67.463G.32.105	SDAT50 x MLD32 - 105	206.75	105	71.7	32	71	M24 x 3.0P	5.10
67.463G.32.135	SDAT50 x MLD32 - 135	236.75	135	71.7	32	71	M24 x 3.0P	5.90
67.463G.42.115	SDAT50 x MLD42 - 115	216.75	115	84.8	42	90	M24 x 3.0P	5.00

Features:

- ▶ Good damping power. The clamping power of MLD32 type is around 1000 N-m.
- ▶ Runout accuracy of MLD holder body: within 0.005mm.
- ▶ Runout accuracy with collet: within 0.02mm.
- ▶ The tolerance requirement of tool shank diameter is h6.
- ▶ Internal bearing cage helps increase the clamping force.
- ▶ After fastening, the nuts and tool holders contact tight to enhance the cutting rigidity.
- ▶ Coolant options: through the center of holder or cutter. Use sealed caps and SR rings for coolant through cutter.

Product information:

- ▶ The pre-balance reaches G6.3 8,000 rpm. Higher balancing grade and revolution can be done upon request but additional charge is needed.
- ▶ AD+B type is available, please inform us when making an order.

Standard Accessory: • NUT • SET SCREW

Collet	Sealed Cap	SR Sealed Ring	Pull Stud	Set Screw	Spanner	Spanner
P.W-32~33	P.W-52	P.W-53	P.W-57	P.W-82	P.W-65~66	P.W-67



SDAT / SLN SIDE LOCK END MILL HOLDER

Dual
DRIVE+

SDAT / SLN 法蘭加厚型側固式立銑刀柄

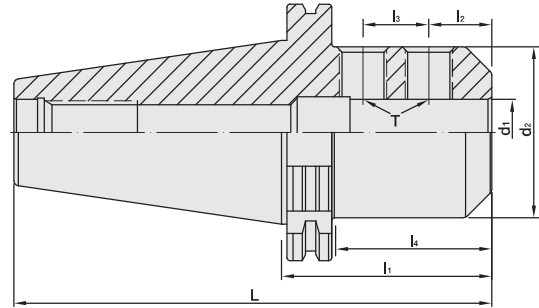

MODEL NO.	TYPE	L	l ₁	l ₂	l ₃	l ₄	d ₁	d ₂	T	WEIGHT (KGS)
66.653.06.050	SDAT40 x SLN6 - 50	118,4	50	18	-	27	6	25	M6 x 1,0P	0,85
66.653.08.050	SDAT40 x SLN8 - 50	118,4	50	18	-	27	8	28	M8 x 1,25P	1,00
66.653.10.050	SDAT40 x SLN10 - 50	118,4	50	20	-	27	10	35	M10 x 1,5P	1,10
66.653.12.050	SDAT40 x SLN12 - 50	118,4	50	22,5	-	30	12	42	M12 x 1,75P	1,15
66.653.16.063	SDAT40 x SLN16 - 63	131,4	63	24	-	43	16	48	M14 x 2,0P	1,40
66.653.20.063	SDAT40 x SLN20 - 63	131,4	63	25	-	43	20	52	M16 x 2,0P	1,30
66.653.25.100	SDAT40 x SLN25 - 100	168,4	100	24	25	80	25	65	M18 x 2,0P	2,40
66.653.32.100	SDAT40 x SLN32 - 100	168,4	100	24	28	80	32	72	M20 x 2,0P	2,70
67.653.06.063	SDAT50 x SLN6 - 63	164,75	63	18,0	-	33	6	25	M6 x 1,0P	3,10
67.653.08.063	SDAT50 x SLN8 - 63	164,75	63	18,0	-	33	8	28	M6 x 1,0P	3,10
67.653.10.063	SDAT50 x SLN10 - 63	164,75	63	20	-	33	10	35	M10 x 1,5P	3,30
67.653.12.063	SDAT50 x SLN12 - 63	164,75	63	22,5	-	40	12	42	M12 x 1,75P	3,50
67.653.16.063	SDAT50 x SLN16 - 63	164,75	63	24	-	40	16	48	M14 x 2,0P	3,45
67.653.20.063	SDAT50 x SLN20 - 63	164,75	63	25	-	40	20	52	M16 x 2,0P	3,50
67.653.25.080	SDAT50 x SLN25 - 80	181,75	80	24	25	59	25	65	M18 x 2,0P	4,20
67.653.32.100	SDAT50 x SLN32 - 100	201,75	100	24	28	78	32	72	M20 x 2,0P	5,00
67.653.40.100	SDAT50 x SLN40 - 100	201,75	100	30	32	80	40	90	M20 x 2,0P	5,60
67.653.42.100	SDAT50 x SLN42 - 100	201,75	100	30	32	80	42	90	M20 x 2,0P	5,70
67.653.50.125	SDAT50 x SLN50 - 125	226,75	125	35	35	105	50	100	M24 x 2,0P	5,90
67.653.63.150	SDAT50 x SLN63 - 150	251,75	150	40	40	130	63	125	M20 x 2,0P	6,20

Features:

- ▶ Internal hole tolerance: H5 (DIN-1835-B standard).
- ▶ The tolerance requirement of tool shank diameter is h6.

Product information:

- ▶ The pre-balance reaches G6.3 8,000 rpm. Higher balancing grade and revolution can be done upon request but additional charge is needed.
- ▶ AD+B type is available, please inform us when making an order.

Pull Stud

Lock Screw



P.W-57



P.W-84

SDAT FACE MILL ARBOR

FMB TYPE

SDAT



SDAT / FMB 法蘭加厚型平面銑刀柄

(DIN 6357-B)

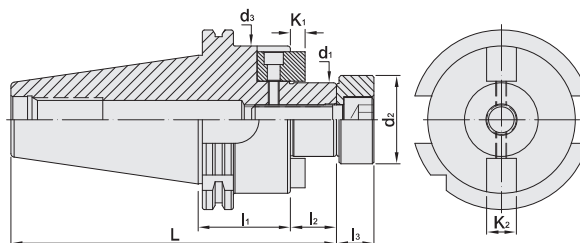



MODEL NO.	TYPE	L	l ₁	l ₂	l ₃	d ₁	d ₂	d ₃	K ₁	K ₂	WEIGHT (KGS)
66.153.22.035	SDAT40 x FMB22 - 35	122.4	35	19	14	22	26	48	5	10	1.20
66.153.27.060	SDAT40 x FMB27 - 60	148.4	60	20	16	27	31.5	58	5	12	1.80
66.153.32.060	SDAT40 x FMB32 - 60	150.4	60	22	16	32	41	66	6	14	2.30
66.153.40.060	SDAT40 x FMB40 - 60	153.4	60	25	20.5	40	48	80	8	16	2.80
67.153.22.035	SDAT50 x FMB22 - 35	155.75	35	19	14	22	26	48	5	10	3.40
67.153.27.035	SDAT50 x FMB27 - 35	156.75	35	20	16	27	31.5	58	5	12	3.50
67.153.32.035	SDAT50 x FMB32 - 35	158.75	35	22	16	32	41	66	6	14	3.70
67.153.40.050	SDAT50 x FMB40 - 50	176.75	50	25	20.5	40	48	80	8	16	4.70
67.153.50.060	SDAT50 x FMB50 - 60	191.75	60	30	25	50	68	95	10	19	5.80

Features:

- ▶ d1 tolerance: h6.

Product information:

- ▶ The pre-balance reaches G6.3 3,000 rpm. Higher balancing grade and revolution can be done upon request but additional charge is needed.
- ▶ AD+B type is available, please inform us when making an order.

Pull Stud	Screw
 P.W-57	 P.W-84



SDAT FACE MILL ARBOR

FMC TYPE

Dual
DRIVE+

SDAT / FMC 法蘭加厚型平面銑刀柄

(DIN 6357-B)

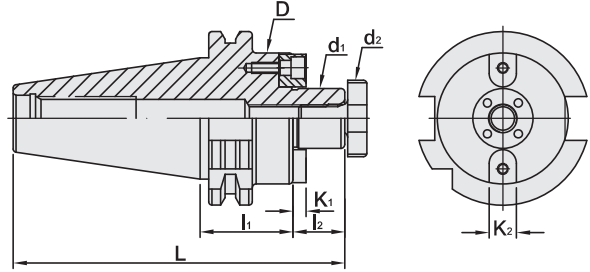

MODEL NO.	TYPE	L	l ₁	l ₂	D	d ₁	d ₂	K ₁	K ₂	WEIGHT (KGS)
66.157.16.050	SDAT40 x FMC16 - 50	135.4	50	17	40	16	40	5	8	1.27
66.157.22.050	SDAT40 x FMC22 - 50	137.5	50	19	50	22	50	4.8	10	1.45
66.157.27.060	SDAT40 x FMC27 - 60	149.4	60	21	60	27	58	5.8	12	1.57
66.157.32.060	SDAT40 x FMC32 - 60	152.4	60	24	78	32	78	6.8	14	1.87
67.157.16.050	SDAT50 x FMC16 - 50	168.75	50	17	40	16	40	5	8	3.05
67.157.22.050	SDAT50 x FMC22 - 50	170.75	50	19	50	22	50	4.8	10	3.07
67.157.27.050	SDAT50 x FMC27 - 50	172.75	50	21	60	27	60	5.8	12	3.10
67.157.32.060	SDAT50 x FMC32 - 60	185.75	60	24	78	23	78	6.8	14	3.65
67.157.40.070	SDAT50 x FMC40 - 70	198.75	70	27	89	40	89	8.3	16	4.25

**Features:**

- ▶ d1 tolerance: h6.

Product information:

- ▶ The pre-balance reaches G6.3 3,000 rpm. Higher balancing grade and revolution can be done upon request but additional charge is needed.
- ▶ AD+B type is available, please inform us when making an order.

Standard Accessory: • NUT • SPANNER

Nut	Pull Stud	Spanner
		
P.W-61	P.W-57	P.W-61

SDAT MORSE TAPER ADAPTER

TANG TYPE



SDAT 法蘭加厚型斜柄鑽頭套筒

(DIN ISO 228-2 / 6383)

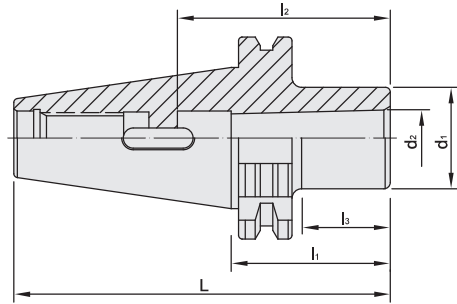

MODEL NO.	TYPE	L	l ₁	l ₂	l ₃	d ₁	d ₂	WEIGHT (KGS)
66.465.01.050	SDAT40 x MTA1 - 50	118.4	50	56	22	25	12.065	1.20
66.465.02.050	SDAT40 x MTA2 - 50	118.4	50	67	27	32	17.78	1.00
66.465.03.070	SDAT40 x MTA3 - 70	138.4	70	84	47	40	23.825	1.10
66.465.04.095	SDAT40 x MTA4 - 95	163.4	95	107	74	48	31.267	1.35
67.465.01.045	SDAT50 x MTA1 - 45	146.75	45	56	22	25	12.065	3.00
67.465.02.060	SDAT50 x MTA2 - 60	161.75	60	67	35	32	17.78	3.10
67.465.03.065	SDAT50 x MTA3 - 65	166.75	65	84	40	40	23.825	3.20
67.465.04.095	SDAT50 x MTA4 - 95	196.75	95	107	70	48	31.267	3.40
67.465.05.105	SDAT50 x MTA5 - 105	206.75	105	135	80	63	44.399	3.60

Features:

- ▶ High accurate working process. Even though using prolonged drill, the concentricity is still within 0.015mm.

Pull Stud



P.W-57



SDAT ADAPTER

Dual
DRIVE+

SDAT 法蘭加厚型套筒

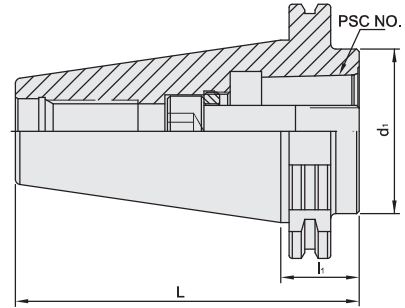

MODEL NO.	TYPE	NO.	L	l ₁	d ₁	T	TORQUE		WEIGHT (KGS)
							MIN.	MAX.	
66.501.32.030	SDAT40 x PSC32 - 30	PSC32	98.4	30	32	M12 x 1.5P	45 Nm	55 Nm	1.40
66.501.40.040	SDAT40 x PSC40 - 40	PSC40	108.4	40	40	M14 x 1.5P	45 Nm	55 Nm	1.50
66.501.50.050	SDAT40 x PSC50 - 50	PSC50	118.4	50	50	M16 x 1.5P	45 Nm	55 Nm	1.60
66.501.63.090	SDAT40 x PSC63 - 90	PSC63	158.4	90	63	M20 x 2.0P	65 Nm	75 Nm	2.00
67.501.32.030	SDAT50 x PSC32 - 30	PSC32	131.75	30	32	M12 x 1.5P	45 Nm	55 Nm	4.20
67.501.40.030	SDAT50 x PSC40 - 30	PSC40	131.75	30	40	M14 x 1.5P	45 Nm	55 Nm	4.30
67.501.50.030	SDAT50 x PSC50 - 30	PSC50	131.75	30	50	M16 x 1.5P	45 Nm	55 Nm	4.40
67.501.63.030	SDAT50 x PSC63 - 30	PSC63	131.75	30	63	M20 x 2.0P	65 Nm	75 Nm	4.50
67.501.63.100	SDAT50 x PSC63 - 100	PSC63	201.75	100	63	M20 x 2.0P	65 Nm	75 Nm	5.00
67.501.63.150	SDAT50 x PSC63 - 150	PSC63	251.75	150	63	M20 x 2.0P	65 Nm	75 Nm	5.20
67.501.63.200	SDAT50 x PSC63 - 200	PSC63	301.75	200	63	M20 x 2.0P	65 Nm	75 Nm	5.40
67.501.63.250	SDAT50 x PSC63 - 250	PSC63	351.75	250	63	M20 x 2.0P	65 Nm	75 Nm	5.80
67.501.63.300	SDAT50 x PSC63 - 300	PSC63	401.75	300	63	M20 x 2.0P	65 Nm	75 Nm	6.20
67.501.80.050	SDAT50 x PSC80 - 50	PSC80	151.75	50	80	M20 x 2.0P	65 Nm	75 Nm	2.90
67.501.80.070	SDAT50 x PSC80 - 70	PSC80	171.75	70	80	M20 x 2.0P	65 Nm	75 Nm	3.30
67.501.80.100	SDAT50 x PSC80 - 100	PSC80	201.75	100	80	M20 x 2.0P	65 Nm	75 Nm	4.00
67.501.80.120	SDAT50 x PSC80 - 120	PSC80	221.75	120	80	M20 x 2.0P	65 Nm	75 Nm	4.70

Pull Stud



P.W-57