

PSC

CATEGORY

ISO 26623 - 1

EOTP ONE-PIECE EXTERNAL TOOL POST	H-2
IOTP ONE-PIECE EXTERNAL TOOL POST	H-2
AL ADAPTER	H-3
HIGH-PRESSURE COOLANT PIPE	H-3
EXTERNAL TURNING TOOL	H-6~15
EXTERNAL TURNING TOOL HOLDER	H-16~17
PSC / STUP INTERNAL BORING BAR	H-18
PSC / IAP INDEXABLE END MILL CUTTER	H-19
PSC / CIAP INDEXABLE END MILL CUTTER	H-20
PSC / MAP INDEXABLE END MILL CUTTER	H-21
PSC / CMAP INDEXABLE END MILL CUTTER	H-22
PSC / SPD HIGH SPEED DRILL	H-23~24
PNER COLLET CHUCK	H-25
PTER COLLET CHUCK	H-26~27
UT COLLET CHUCK	H-28~29
ER COLLET CHUCK	H-30
SKX COLLET CHUCK	H-31
SK3 COLLET CHUCK	H-32
SKS COLLET CHUCK	H-33
SBL SLIM-FIT COLLET CHUCK	H-34
SBLC SLIM-FIT COLLET CHUCK	H-35
MLD MULTI - LOCK MILLING CHUCK	H-36~37
SLN SIDE LOCK END MILL HOLDER	H-38~40
FACE MILL ARBOR [FMA/FMB TYPE]	H-41~42
FACE MILL ARBOR [FMC TYPE]	H-43
SCA SIDE CUTTER ADAPTER	H-44
EXTENSION ADAPTER	H-45~46
BLANK	H-47

EOTP ONE-PIECE EXTERNAL TOOL POST

EOTP 一體式外徑刀座

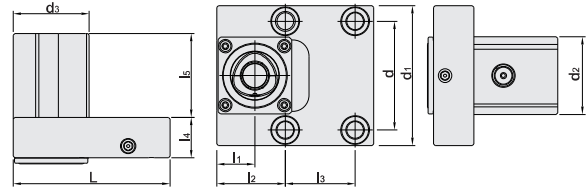

T W PAT NO. M507816
J P PAT NO. 3203371
D E PAT NO. Nr.202016100572

MODEL NO.	TYPE	L	l ₁	l ₂	l ₃	l ₄	l ₅	d	d ₁	d ₂	d ₃	APPLICABLE TYPE	WEIGHT (KGS)
305.C4.TLE.OR	EOTP40 - OR	108.5	24.5	43.5	35	26	54	76	105	50	49	PSC40	2.81
305.C4.TLE.HAAS	EOTP40 - HA	101	24.5	44.1	45	26	54	70	90	50	49	PSC40	2.40
305.C4.TLE.MORI	EOTP40 - MO	108.5	24.5	44	35	26	54	76	105	50	49	PSC40	2.88
305.C4.TLE.MAZAK	EOTP40 - MA	104	24.5	32.75	60	33.5	45	84	104	49	47.75	PSC40	2.90
305.C4.TLE.GW	EOTP40 - GW	114	24.5	49	35	26	54	76	105	50	49	PSC40	2.99

Features:

- ▶ One-piece tool post with PSC interface, with high rigidity and great convenience. ▶ Quick change design.
- ▶ Needn't be connected with high-pressure coolant pipe: internal coolant supply 70BAR.

Product information: ▶ Refer to P.H-4 for turning tool.

IOTP ONE-PIECE INTERNAL TOOL POST

IOTP 一體式內徑刀座

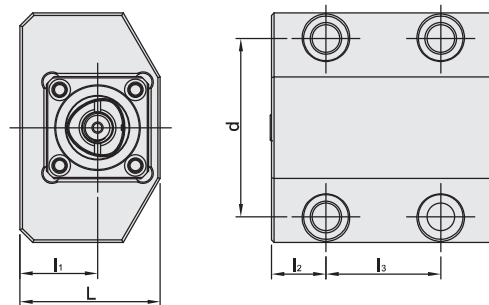

T W PAT NO. M507816
J P PAT NO. 3203371
D E PAT NO. Nr.202016100572

MODEL NO.	TYPE	L	l ₁	l ₂	l ₃	d	APPLICABLE TYPE	WEIGHT (KGS)
305.C4.HAAS	IOTP40 - HA	60	30.4	21.3	45	70	PSC40	2.70
305.C4.MAZAK	IOTP40 - MA	93.2	63	10	60	84	PSC40	4.41
305.C4.MORI	IOTP40 - MO	80	46	25	35	76	PSC40	4.10
305.C4.OR	IOTP40 - OR	81	46	25	35	76	PSC40	4.15
305.C4.GW	IOTP40 - GW	75	40	25	35	76	PSC40	4.20

Features:

- ▶ One-piece tool post with PSC interface, with high rigidity and great convenience.
- ▶ Quick change design.
- ▶ Needn't be connected with high-pressure coolant pipe: internal coolant supply 70BAR.

AL ADAPTER FOR PSC TOOL HOLDER

AL 車床套筒 [PSC 刀桿專用]

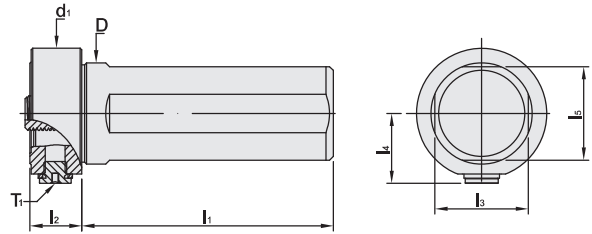

MODEL NO.	TYPE	l ₁	l ₂	l ₃	l ₄	l ₅	D	d ₁	T ₁	APPLICABLE MACHINE	WEIGHT (KGS)
161.C25.073	AL3 x C25 - 73	73	25	23	26	23	25	45.5	PF1/8	-	0.48
161.C32.080	AL3 x C32 - 80	80	18	30	26	30	32	45.5	PF1/8	-	0.53
161.C32.080A	AL3 x C32 - 80 - A	80	18	30	26	30	32	45.5	PF1/8	OR	0.57
161.C40.100	AL3 x C40 - 100	100	18	37	26	37	40	45.5	PF1/8	-	0.94
162.C40.100	AL4 x C40 - 100	99.5	20.5	37	28	37	40	51.5	PF1/8	-	0.99
162.C40.100A	AL4 x C40 - 100 - A	99.5	20.5	37	28	37	40	51.5	PF1/8	OR	0.98
162.C40.100B	AL4 x C40 - 100 - B	99.5	20.5	37	28	38.5	40	51.5	PF1/8	YIPC	0.99
163.C50.120	AL5 x C50 - 120	120	24	47	33	47	50	61.5	PF1/8	-	1.82

Wrench



P.W-66

Features:

- ▶ Used for lathe. ▶ Quick change design. ▶ Modular system: internal hole 25 32 40 50.

HIGH-PRESSURE COOLANT PIPE

PSC 高壓水管

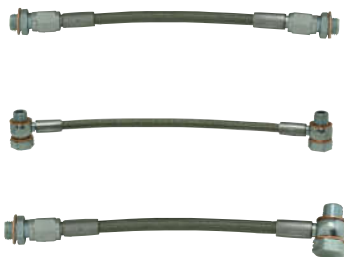

MODEL NO.	TYPE	LENGTH	MAX. WATER PRESSURE
310.A.150	HOSE - A - 150	150	80 bar
310.A.200	HOSE - A - 200	200	80 bar
310.B.150	HOSE - B - 150	150	80 bar
310.B.200	HOSE - B - 200	200	80 bar
310.C.150	HOSE - C - 150	150	80 bar
310.C.200	HOSE - C - 200	200	80 bar

REFERENCE DETAILS

DIN ISO 26623 - 1

- ▶ Shank body standard: **DIN ISO 26623-1**
- ▶ Taper tolerance < **AT3**
- ▶ Hardness > **HRC 56°**
- ▶ Surface roughness: Ra < **0.25 μm**
- ▶ Roundness < **0.8 μm**
- ▶ Carbon depth > **0.8mm**
- ▶ The shank has pre-balance at G6.3, and can provide precision balance at G2.5.
It can be ordered by request.

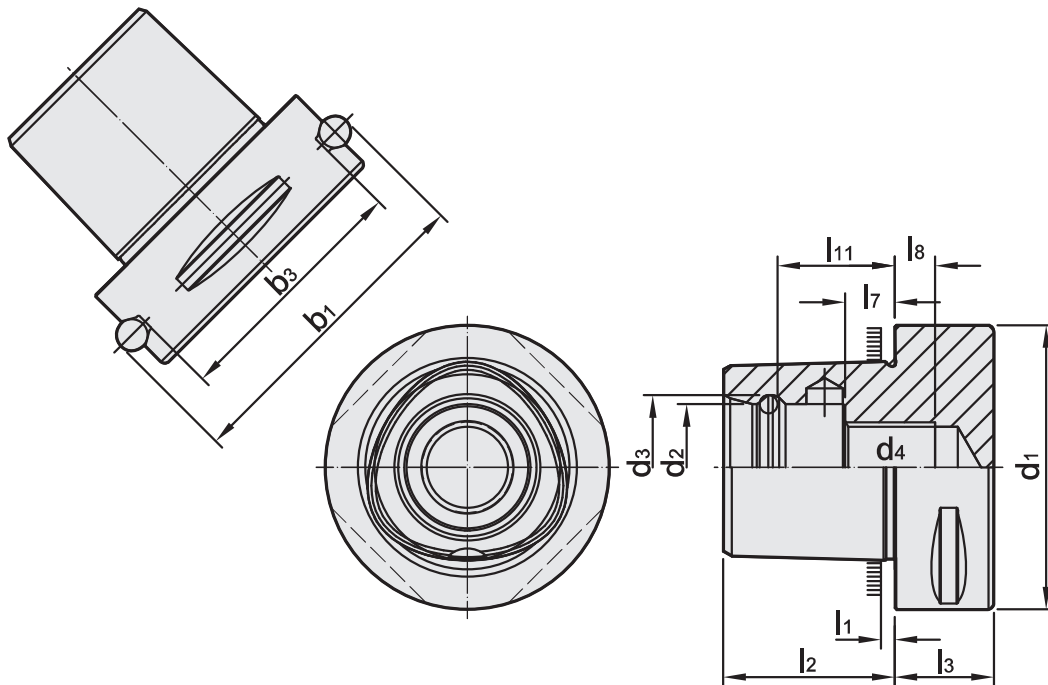

PSC	b ₁ ±0.1	b ₃ ±0.1	d ₁ ±0.1	d ₂ +0.1 -0.05	d ₃ ±0.05	d ₄
32	39	27.9	32	15	16.5	M12 x 1.5P
40	46	34.9	40	18	20	M14 x 1.5P
50	59.3	44	50	21	24	M16 x 1.5P
63	70.7	55.4	63	28	32	M20 x 2.0P
80	86	70.7	80	32	38	M20 x 2.0P
80X	110	88.3	100	32	38	M20 x 2.0P
PSC	l ₁	l ₂ ±0.1	l ₃ min	l ₇ ±0.15	l ₈ min	l ₁₁ ±0.1
32	2.5	19	15	6	6	13.5
40	2.5	24	20	9	6	17.5
50	3	30	20	10	7	22
63	3	38	22	11	9	26
80	3	48	30	20	0	34
80X	3	48	32	20	0	34

DESIGNATION OF PSC

PSC 編碼原則

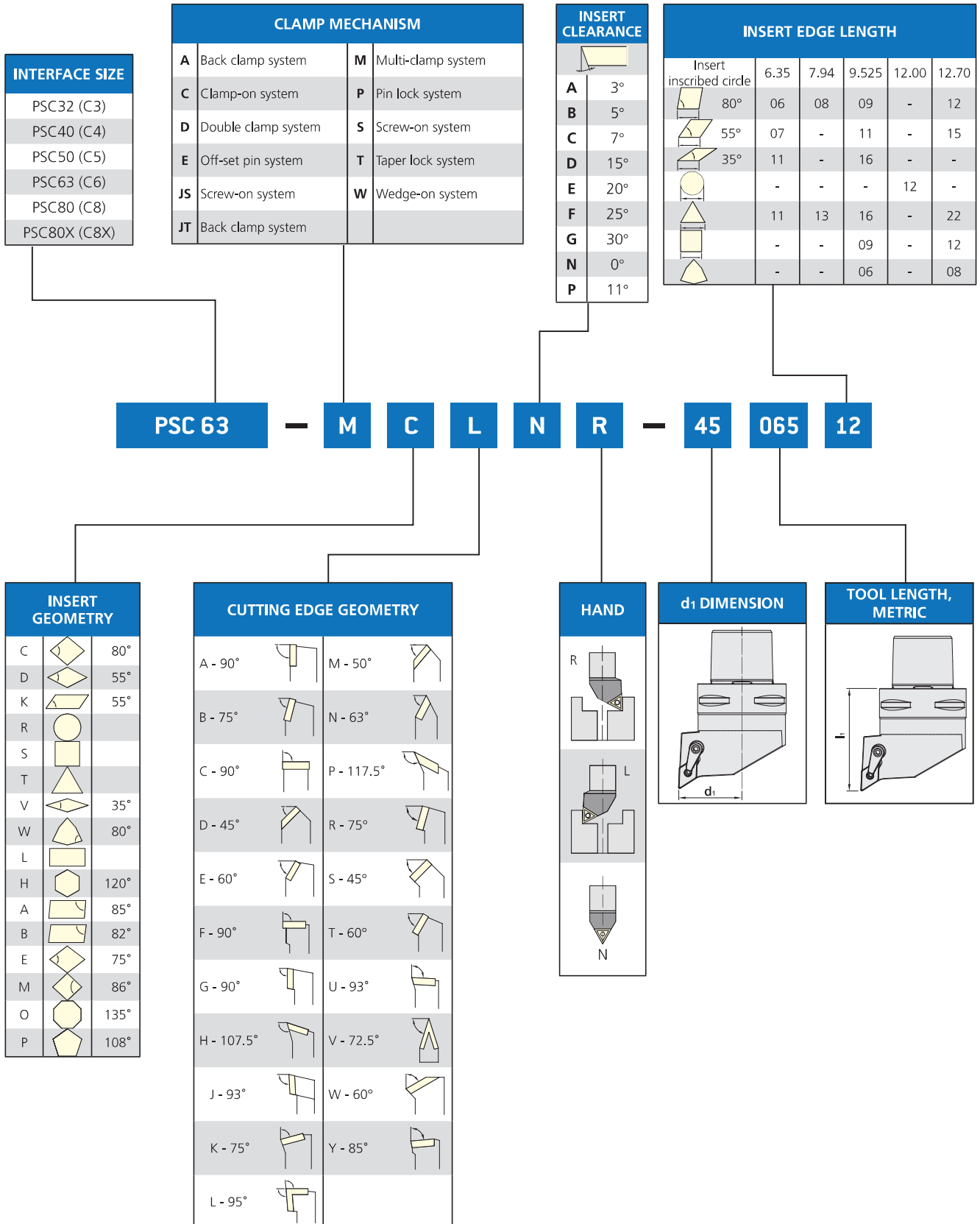

PSC / MWLN EXTERNAL TURNING TOOL

PSC / MWLN 外徑車刀



台灣精品 2012
TAIWAN EXCELLENCE

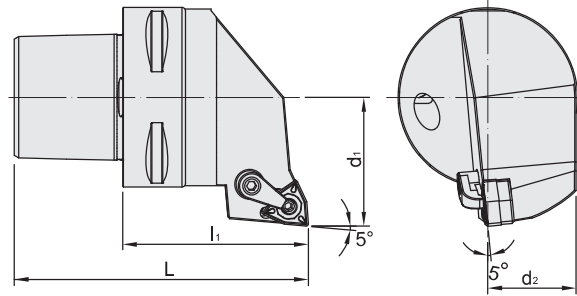

MODEL NO.	TYPE	L	l ₁	d ₁	d ₂	Insert	WEIGHT (KGS)
140.478.08R.045	PSC32 - MWLNR - 22045 - 08	64	45	22	18.1	WN..0804	0.22
140.478.08L.045	PSC32 - MWLNL - 22045 - 08	64	45	22	18.1	WN..0804	0.22
141.478.08R.050	PSC40 - MWLNR - 27050 - 08	74	50	27	22.5	WN..0804	0.42
141.478.08L.050	PSC40 - MWLNL - 27050 - 08	74	50	27	22.5	WN..0804	0.42
142.478.08R.060	PSC50 - MWLNR - 35060 - 08	90	60	35	28.65	WN..0804	0.78
142.478.08L.060	PSC50 - MWLNL - 35060 - 08	90	60	35	28.65	WN..0804	0.78
143.478.08R.065	PSC63 - MWLNR - 45065 - 08	103	65	45	31	WN..0804	0.80
143.478.08L.065	PSC63 - MWLNL - 45065 - 08	103	65	45	31	WN..0804	0.80

Product information:

- ▶ Inserts are optional accessories. Need to be purchased additionally.

Accessory:

Insert	Clamp	Shim	Screw	Screw
				
WN..0804	MC620	WMS432	MS630	MLP46L-A

PSC / MTJN EXTERNAL TURNING TOOL

PSC / MTJN 外徑車刀



台灣精品 2012
TAIWAN EXCELLENCE

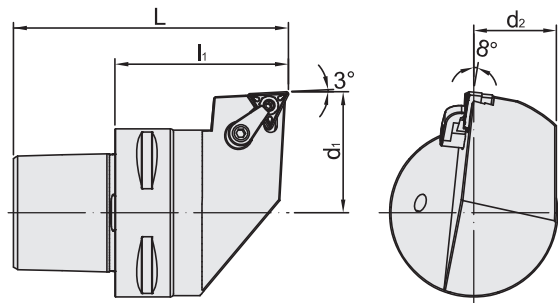

MODEL NO.	TYPE	L	l ₁	d ₁	d ₂	Insert	WEIGHT (KGS)
140.477.16R.045	PSC32 - MTJNR - 22045 - 16	64	45	22	18.1	TN..1604	0.22
140.477.16L.045	PSC32 - MTJNL - 22045 - 16	64	45	22	18.1	TN..1604	0.22
141.477.16R.050	PSC40 - MTJNR - 27050 - 16	74	50	27	22.5	TN..1604	0.42
141.477.16L.050	PSC40 - MTJNL - 27050 - 16	74	50	27	22.5	TN..1604	0.42
142.477.16R.060	PSC50 - MTJNR - 35060 - 16	90	60	35	28.65	TN..1604	0.78
142.477.16L.060	PSC50 - MTJNL - 35060 - 16	90	60	35	28.65	TN..1604	0.78
143.477.16R.065	PSC63 - MTJNR - 45065 - 16	103	65	45	31	TN..1604	0.80
143.477.16L.065	PSC63 - MTJNL - 45065 - 16	103	65	45	31	TN..1604	0.80

Product information:

- ▶ Inserts are optional accessories. Need to be purchased additionally.

Accessory:

Insert	Clamp	Shim	Screw	Screw
TN..1604	MC620	TMS322	MS630	MLP34L-A



PSC / MCLN EXTERNAL TURNING TOOL

PSC / MCLN 外徑車刀



台灣精品 2012
TAIWAN EXCELLENCE

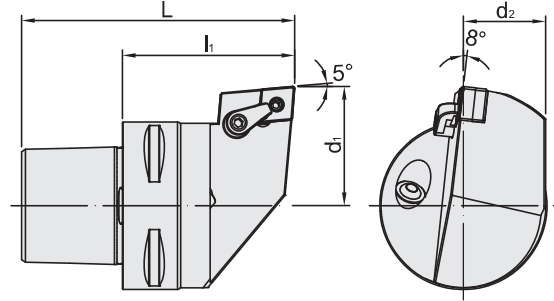

MODEL NO.	TYPE	L	l ₁	d ₁	d ₂	Insert	WEIGHT (KGS)
140.475.12R.045	PSC32 - MCLNR - 22045 - 12	64	45	22	18.1	CN..1204	0.22
140.475.12L.045	PSC32 - MCLNL - 22045 - 12	64	45	22	18.1	CN..1204	0.22
141.475.12R.050	PSC40 - MCLNR - 27050 - 12	74	50	27	22.5	CN..1204	0.42
141.475.12L.050	PSC40 - MCLNL - 27050 - 12	74	50	27	22.5	CN..1204	0.42
142.475.12R.060	PSC50 - MCLNR - 35060 - 12	90	60	35	28.65	CN..1204	0.78
142.475.12L.060	PSC50 - MCLNL - 35060 - 12	90	60	35	28.65	CN..1204	0.78
143.475.12R.065	PSC63 - MCLNR - 45065 - 12	103	65	45	31	CN..1204	0.80
143.475.12L.065	PSC63 - MCLNL - 45065 - 12	103	65	45	31	CN..1204	0.80

Product information:

► Inserts are optional accessories. Need to be purchased additionally.

Accessory:

Insert	Clamp	Shim	Screw	Screw
				
CN..1204	MC620	MCS432	MS620	MLP46L-A

PSC / MDJN EXTERNAL TURNING TOOL

PSC / MDJN 外徑車刀

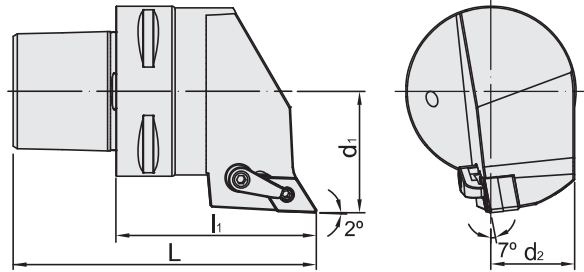

MODEL NO.	TYPE	L	l ₁	d ₁	d ₂	Insert	WEIGHT (KGS)
140.476.15R.045	PSC32 - MDJNR - 22045 - 15	64	45	22	18.1	DN..1504	0.22
140.476.15L.045	PSC32 - MDJNL - 22045 - 15	64	45	22	18.1	DN..1504	0.22
141.476.15R.050	PSC40 - MDJNR - 27050 - 15	74	50	27	22.5	DN..1504	0.42
141.476.15L.050	PSC40 - MDJNL - 27050 - 15	74	50	27	22.5	DN..1504	0.42
142.476.15R.060	PSC50 - MDJNR - 35060 - 15	90	60	35	28.65	DN..1504	0.78
142.476.15L.060	PSC50 - MDJNL - 35060 - 15	90	60	35	28.65	DN..1504	0.78
143.476.15R.075	PSC63 - MDJNR - 45075 - 15	113	75	45	31	DN..1504	0.80
143.476.15L.075	PSC63 - MDJNL - 45075 - 15	113	75	45	31	DN..1504	0.80

Product information:

► Inserts are optional accessories. Needs to be purchased additionally.

Accessory:

Insert	Clamp	Shim	Screw	Screw
DN..1504	MC622	DMS442	MS630	MLP46L-A



PSC / DWLN EXTERNAL TURNING TOOL

PSC / DWLN 外徑車刀

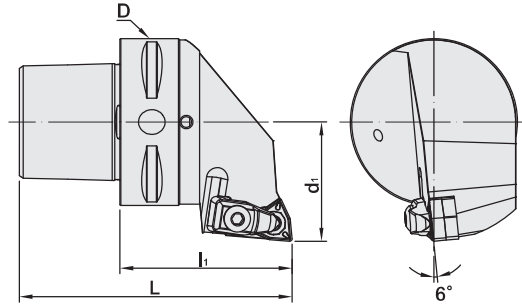







MODEL NO.	TYPE	L	li	D	di	Insert	WEIGHT (KGS)
141.93.08R.050	PSC40 - DWLNR - 27050 - 08	74	50	40	27	WN..0804	0.42
141.93.08L.050	PSC40 - DWLNL - 27050 - 08	74	50	40	27	WN..0804	0.42
142.93.08R.060	PSC50 - DWLNR - 35060 - 08	90	60	50	35	WN..0804	0.78
142.93.08L.060	PSC50 - DWLNL - 35060 - 08	90	60	50	35	WN..0804	0.78
143.93.08R.065	PSC63 - DWLNR - 45065 - 08	103	65	63	45	WN..0804	0.80
143.93.08L.065	PSC63 - DWLNL - 45065 - 08	103	65	63	45	WN..0804	0.80
144.93.08R.080	PSC80 - DWLNR - 55080 - 08	128	80	80	55	WN..0804	2.64
144.93.08L.080	PSC80 - DWLNL - 55080 - 08	128	80	80	55	WN..0804	2.64

Product information:

- ▶ Inserts are optional accessories. Needs to be purchased additionally.

Accessory:

Insert	Clamp	Shim	Screw	Screw	Spring
					
WN..0804	C2RA	W08BM	SM6x10xA1	CM6x25C	SPR4

PSC / DTJN EXTERNAL TURNING TOOL

PSC / DTJN 外徑車刀

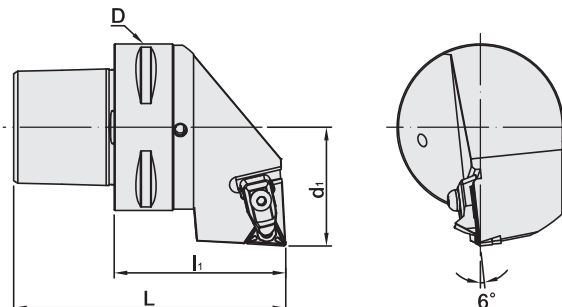

MODEL NO.	TYPE	L	li	D	di	Insert	WEIGHT (KGS)
140.92.16R.040	PSC32 - DTJNR - 22040 - 16	59	40	32	22	TN..1604	0.22
140.92.16L.040	PSC32 - DTJNL - 22040 - 16	59	40	32	22	TN..1604	0.22
141.92.16R.050	PSC40 - DTJNR - 27050 - 16	74	50	40	27	TN..1604	0.42
141.92.16L.050	PSC40 - DTJNL - 27050 - 16	74	50	40	27	TN..1604	0.42
142.92.16R.060	PSC50 - DTJNR - 35060 - 16	90	60	50	35	TN..1604	0.78
142.92.16L.060	PSC50 - DTJNL - 35060 - 16	90	60	50	35	TN..1604	0.78
143.92.16R.065	PSC63 - DTJNR - 45065 - 16	103	65	63	45	TN..1604	0.80
143.92.16L.065	PSC63 - DTJNL - 45065 - 16	103	65	63	45	TN..1604	0.80

Product information:

► Inserts are optional accessories. Needs to be purchased additionally.

Accessory:

Insert	Clamp	Shim	Screw	Screw	Spring
TN..1604	C1RA	T16BM	SM5x8.65xA1	CM5X22C	SPR6



PSC / DCLN EXTERNAL TURNING TOOL

PSC / DCLN 外徑車刀

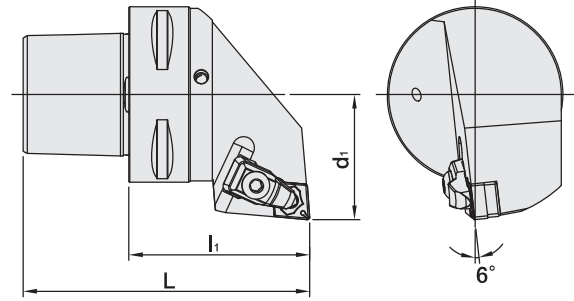







MODEL NO.	TYPE	L	li	di	Insert	WEIGHT (KGS)
140.90.12R.045	PSC32 - DCLNR - 22045 - 12	64	45	22	CN..1204	0.22
140.90.12L.045	PSC32 - DCLNL - 22045 - 12	64	45	22	CN..1204	0.22
141.90.12R.050	PSC40 - DCLNR - 27050 - 12	74	50	27	CN..1204	0.42
141.90.12L.050	PSC40 - DCLNL - 27050 - 12	74	50	27	CN..1204	0.42
142.90.12R.060	PSC50 - DCLNR - 35060 - 12	90	60	35	CN..1204	0.78
142.90.12L.060	PSC50 - DCLNL - 35060 - 12	90	60	35	CN..1204	0.78
143.90.12R.065	PSC63 - DCLNR - 45065 - 12	103	65	45	CN..1204	0.80
143.90.12L.065	PSC63 - DCLNL - 45065 - 12	103	65	45	CN..1204	0.80
144.90.12R.080	PSC80 - DCLNR - 55080 - 12	128	80	55	CN..1204	2.64
144.90.12L.080	PSC80 - DCLNL - 55080 - 12	128	80	55	CN..1204	2.64

Product information:

- Inserts are optional accessories. Needs to be purchased additionally.

Accessory:

Insert	Clamp	Shim	Screw	Screw	Spring
					
CN..1204	C2RA	C12BM	SM6x10xA1	CM6x25C	SPR4

PSC / MCMN EXTERNAL TURNING TOOL

PSC / MCMN 外徑車刀

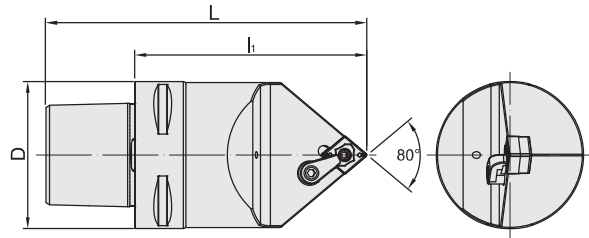

MODEL NO.	TYPE	L	l ₁	D	Insert	WEIGHT (KGS)
140.480.12N.050	PSC32 - MCMNN - 00050 - 12	69	50	32	CN..1204	0.24
141.480.12N.060	PSC40 - MCMNN - 00060 - 12	84	60	40	CN..1204	0.44
142.480.12N.070	PSC50 - MCMNN - 00070 - 12	100	70	50	CN..1204	0.76
143.480.12N.100	PSC63 - MCMNN - 00100 - 12	138	100	63	CN..1204	0.86

Accessory:

Insert	Clamp	Shim	Screw	Screw
				
CN..1204	MC620	SMC432	MS620	MLP46L-A

Product information:

► Inserts are optional accessories. Needs to be purchased additionally.

PSC / MDNN EXTERNAL TURNING TOOL

PSC / MDNN 外徑車刀

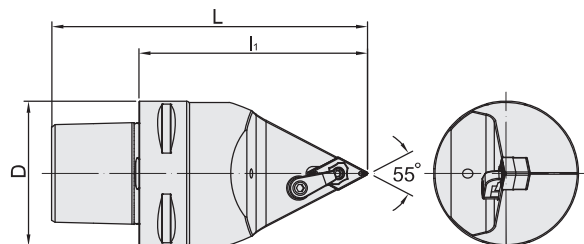

MODEL NO.	TYPE	L	l ₁	D	Insert	WEIGHT (KGS)
140.481.15N.050	PSC32 - MDNNN - 00050 - 15	69	50	32	DN..1504	0.22
141.481.15N.060	PSC40 - MDNNN - 00060 - 15	84	60	40	DN..1504	0.40
142.481.15N.070	PSC50 - MDNNN - 00070 - 15	100	70	50	DN..1504	0.70
143.481.15N.100	PSC63 - MDNNN - 00100 - 15	138	100	63	DN..1504	0.80

Accessory:

Insert	Clamp	Shim	Screw	Screw
				
DN..1504	MC622	SMD463	MS625	MLP46L-A

Product information:

► Inserts are optional accessories. Needs to be purchased additionally.



PSC / MVVN EXTERNAL TURNING TOOL

PSC / MVVN 外徑車刀

 台灣精品 2012
 TAIWAN EXCELLENCE

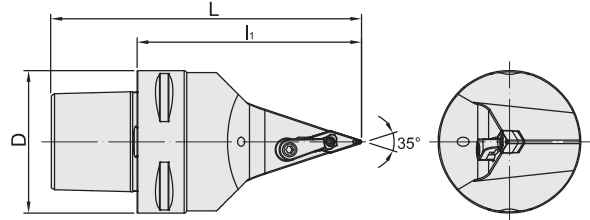

MODEL NO.	TYPE	L	l ₁	D	Insert	WEIGHT (KGS)
140.484.16N.055	PSC32 - MVVNN - 00055 - 16	74	55	32	VN..1604	0.22
141.484.16N.060	PSC40 - MVVNN - 00060 - 16	84	60	40	VN..1604	0.38
142.484.16N.070	PSC50 - MVVNN - 00070 - 16	100	70	50	VN..1604	0.68
143.484.16N.100	PSC63 - MVVNN - 00100 - 16	138	100	63	VN..1604	0.78

Product information:

► Inserts are optional accessories. Needs to be purchased additionally.

Accessory:

Insert	Clamp	Shim	Screw	Screw
				
VN..1604	MC622	SMV322	MS630	MLP34L-A

PSC / MVLN EXTERNAL TURNING TOOL

PSC / MVLN 外徑車刀



台灣精品 2012
TAIWAN EXCELLENCE

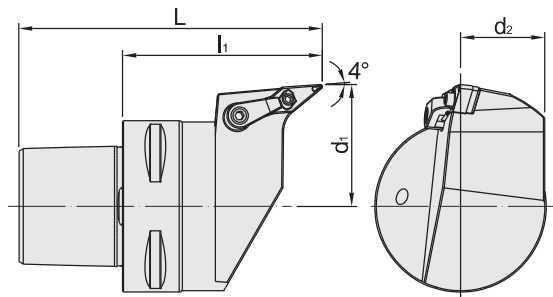

MODEL NO.	TYPE	L	l ₁	d ₁	d ₂	Insert	WEIGHT (KGS)
140.479.16R.050	PSC32 - MVLNR - 20050 - 16	69	50	20	18.1	VN..1604	0.22
140.479.16L.050	PSC32 - MVLNL - 20050 - 16	69	50	20	18.1	VN..1604	0.22
141.479.16R.055	PSC40 - MVLNR - 27055 - 16	79	55	27	22.5	VN..1604	0.42
141.479.16L.055	PSC40 - MVLNL - 27055 - 16	79	55	27	22.5	VN..1604	0.42
142.479.16R.060	PSC50 - MVLNR - 35060 - 16	90	60	35	28.65	VN..1604	0.78
142.479.16L.060	PSC50 - MVLNL - 35060 - 16	90	60	35	28.65	VN..1604	0.78
143.479.16R.075	PSC63 - MVLNR - 45075 - 16	113	75	45	31	VN..1604	0.80
143.479.16L.075	PSC63 - MVLNL - 45075 - 16	113	75	45	31	VN..1604	0.80

Product information:

► Inserts are optional accessories. Needs to be purchased additionally.

Accessory:

Insert	Clamp	Shim	Screw	Screw
VN..1604	MC622	SMV322	MS630	MLP34L-A



PSC / SV EXTERNAL TURNING TOOL HOLDER

PSC / SV 外徑車刀架



台灣精品 2012
TAIWAN EXCELLENCE

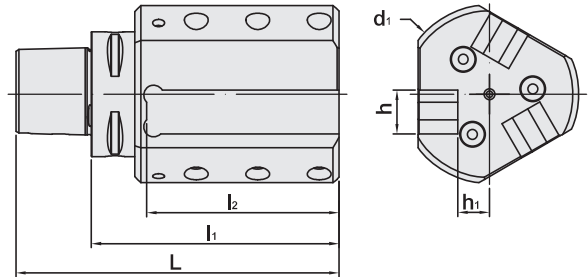

MODEL NO.	TYPE	L	l ₁	l ₂	d ₁	h	h ₁	WEIGHT (KGS)
142.SV20R.123	PSC50 x SV20R - 123	153	123	97	90	20	16	3.56
142.SV20L.123	PSC50 x SV20L - 123	153	123	97	90	20	16	3.56
143.SV20R.125	PSC63 x SV20R - 125	163	125	97	90	20	16	3.58
143.SV20L.125	PSC63 x SV20L - 125	163	125	97	90	20	16	3.58
144.SV32R.150	PSC80 x SV32R - 150	198	150	114	120	32	20	7.13
144.SV32L.150	PSC80 x SV32L - 150	198	150	114	120	32	20	7.13

PSC / SN EXTERNAL TURNING TOOL HOLDER

PSC / SN 外徑車刀架



台灣精品 2012
TAIWAN EXCELLENCE

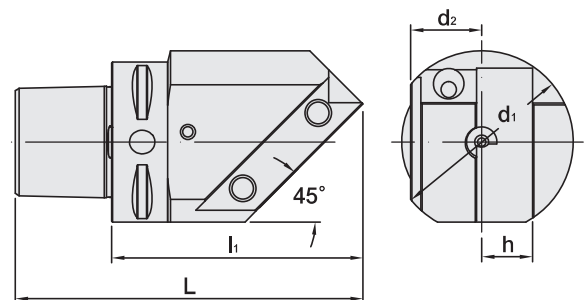

MODEL NO.	TYPE	L	l ₁	d ₁	d ₂	h	WEIGHT (KGS)
142.SN20R.097	PSC50 x SN20R - 97	127	97	72	31.5	20	1.66
142.SN20L.097	PSC50 x SN20L - 97	127	97	72	31.5	20	1.66
143.SN20R.099	PSC63 x SN20R - 99	137	99	72	31.5	20	2.10
143.SN20L.099	PSC63 x SN20L - 99	137	99	72	31.5	20	2.10
144.SN32R.135	PSC80 x SN32R - 135	183	135	140	45	32	6.51
144.SN32L.135	PSC80 x SN32L - 135	183	135	140	45	32	6.51

PSC / S EXTERNAL TURNING TOOL HOLDER

PSC / S 外徑車刀架



台灣精品 2012
TAIWAN EXCELLENCE

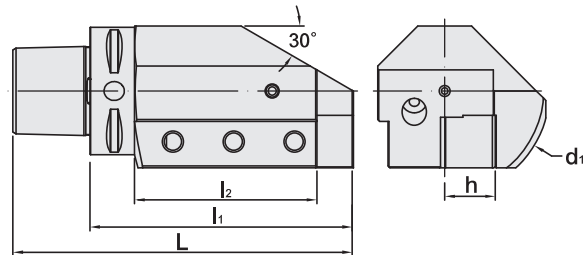

MODEL NO.	TYPE	L	l ₁	l ₂	d ₁	h	WEIGHT (KGS)
142.S20R.098	PSC50 x S20R - 98	128	98	68	90	20	2.22
142.S20L.098	PSC50 x S20L - 98	128	98	68	90	20	2.11
143.S20R.100	PSC63 x S20R - 100	138	100	75	90	20	2.34
143.S20L.100	PSC63 x S20L - 100	138	100	75	90	20	2.34
143.S25R.130	PSC63 x S25R - 130	168	130	102	103.5	25	3.93
143.S25L.130	PSC63 x S25L - 130	168	130	102	103.5	25	3.93
144.S32L.140	PSC80 x S32L - 140	188	140	130	110	32	5.05
144.S32R.140	PSC80 x S32R - 140	188	140	130	110	32	5.05
145.S32L.143	PSC80X x S32L - 143	191	143	133	145	32	7.75
145.S32R.143	PSC80X x S32R - 143	191	143	133	145	32	7.75

PSC / STUP INTERNAL BORING BAR

PSC / STUP 內徑車刀

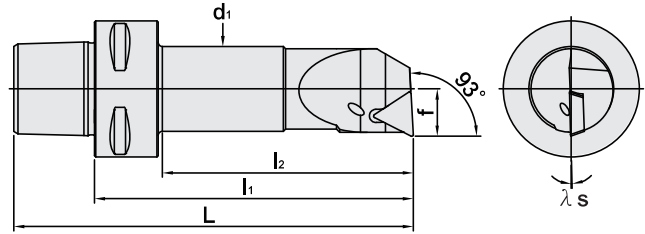



MODEL NO.	TYPE	L	l ₁	l ₂	d ₁	f	λ _s	INSERT	WEIGHT (KGS)
140.761i.16R.065	PSC32 - STUPR - 09065 - 11	84	65	48	16	09	-4	TP.1103	0.27
140.761i.16L.065	PSC32 - STUPL - 09065 - 11	84	65	48	16	09	-4	TP.1103	0.27
140.761i.20R.075	PSC32 - STUPR - 11075 - 11	94	75	59	20	11	-2	TP.1103	0.35
140.761i.20L.075	PSC32 - STUPL - 11075 - 11	94	75	59	20	11	-2	TP.1103	0.35
140.761i.25R.090	PSC32 - STUPR - 14090 - 16	109	90	74	25	14	-3	TP.1603	0.50
140.761i.25L.090	PSC32 - STUPL - 14090 - 16	109	90	74	25	14	-3	TP.1603	0.50
141.761i.16R.070	PSC40 - STUPR - 09070 - 11	94	70	47	16	09	-4	TP.1103	0.34
141.761i.16L.070	PSC40 - STUPL - 09070 - 11	94	70	47	16	09	-4	TP.1103	0.34
141.761i.20R.080	PSC40 - STUPR - 11080 - 11	104	80	57	20	11	-2	TP.1103	0.42
141.761i.20L.080	PSC40 - STUPL - 11080 - 11	104	80	57	20	11	-2	TP.1103	0.42
141.761i.25R.090	PSC40 - STUPR - 14090 - 16	114	90	69	25	14	-3	TP.1603	0.55
141.761i.25L.090	PSC40 - STUPL - 14090 - 16	114	90	69	25	14	-3	TP.1603	0.55
141.761i.32R.110	PSC40 - STUPR - 20110 - 16	134	110	89	32	20	-2	TP.1604	0.87
141.761i.32L.110	PSC40 - STUPL - 20110 - 16	134	110	89	32	20	-2	TP.1604	0.87

Product information:

- ▶ Inserts are optional accessories. Needs to be purchased additionally.

ACCESSORIES

Insert	Screw	Wrench
		
TP.1103	M3-8.0-4.0-46	T9
TP.1603	M4-10-5.0-43	T15

PSC / IAP INDEXABLE END MILL CUTTER

PSC / IAP 直角高速銑刀

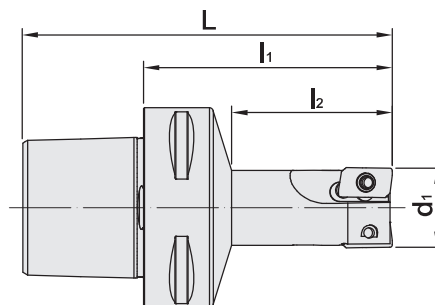



MODEL NO.	TYPE	L	l ₁	l ₂	d ₁	TEETH	INSERT	WEIGHT (KGS)
140.244.16.050	PSC32 x IAP16 - 50 - 2T	69	50	25	16	2	AP..1003	0.20
140.244.20.050	PSC32 x IAP20 - 50 - 2T	69	50	25	20	2	AP..1003	0.20
140.245.20.050	PSC32 x IAP20 - 50 - 3T	69	50	25	20	3	AP..1003	0.30
140.244.25.050	PSC32 x IAP25 - 50 - 2T	69	50	32	25	2	AP..1003	0.20
140.245.25.050	PSC32 x IAP25 - 50 - 3T	69	50	32	25	3	AP..1003	0.30
140.245.32.050	PSC32 x IAP32 - 50 - 3T	69	50	35	32	3	AP..1003	0.20
141.244.16.050	PSC40 x IAP16 - 50 - 2T	74	50	25	16	2	AP..1003	0.50
141.244.20.050	PSC40 x IAP20 - 50 - 2T	74	50	25	20	2	AP..1003	0.50
141.244.25.055	PSC40 x IAP25 - 55 - 2T	79	55	32	25	2	AP..1003	0.50
141.245.25.055	PSC40 x IAP25 - 55 - 3T	79	55	32	25	3	AP..1003	0.50
141.245.32.065	PSC40 x IAP32 - 65 - 3T	89	65	40	32	3	AP..1003	0.60
142.245.20.095	PSC50 x IAP20 - 95 - 3T	125	95	40	20	3	AP..1003	1.00
142.245.25.095	PSC50 x IAP25 - 95 - 3T	125	95	45	25	3	AP..1003	1.10
142.245.32.065	PSC50 x IAP32 - 65 - 3T	95	65	40	32	3	AP..1003	1.50
142.245.40.080	PSC50 x IAP40 - 80 - 3T	110	80	40	40	3	AP..1604	1.10
142.247.50.060	PSC50 x IAP50 - 60 - 5T	90	60	60	50	5	AP..1604	1.00
142.247.63.060	PSC50 x IAP63 - 60 - 5T	90	60	60	63	5	AP..1604	1.40
143.245.20.110	PSC63 x IAP20 - 110 - 3T	148	110	40	20	3	AP..1003	1.60
143.244.20.165	PSC63 x IAP20 - 165 - 2T	203	165	60	20	2	AP..1003	1.60
143.245.25.110	PSC63 x IAP25 - 110 - 3T	148	110	45	25	3	AP..1003	1.60
143.245.32.080	PSC63 x IAP32 - 80 - 3T	118	80	40	32	3	AP..1003	1.50
143.245.32.110	PSC63 x IAP32 - 110 - 3T	148	110	50	32	3	AP..1003	1.70
143.246.40.080	PSC63 x IAP40 - 80 - 4T	118	80	40	40	4	AP..1003	1.60
143.247.40.080	PSC63 x IAP40 - 80 - 5T	118	80	40	40	5	AP..1003	1.60
143.245.40.100	PSC63 x IAP40 - 100 - 3T	138	100	50	40	3	AP..1604	1.80
143.246.50.080	PSC63 x IAP50 - 80 - 4T	118	80	40	50	4	AP..1604	1.80
143.247.63.060	PSC63 x IAP63 - 60 - 5T	98	60	38	63	5	AP..1604	2.20
143.247.66.060	PSC63 x IAP66 - 60 - 5T	98	60	60	66	5	AP..1604	1.90
143.247.66.080	PSC63 x IAP66 - 80 - 5T	118	80	80	66	5	AP..1604	2.30
143.248.80.060	PSC63 x IAP80 - 60 - 6T	98	60	60	80	6	AP..1604	2.20

Product information:

- ▶ One-piece design improves rigidity.
- ▶ Stable insert seat and excellent metal chips removal capacity.
- ▶ Inserts are optional accessories. Needs to be purchased additionally.

ACCESSORIES

Insert	Screw	Wrench
 AP..1003	 M2.5-6.45-3.7-60	 T8
AP..1604	M4-10-5.7-60	T15



PSC / CIAP INDEXABLE END MILL CUTTER

PSC / CIAP 直角高速銑刀

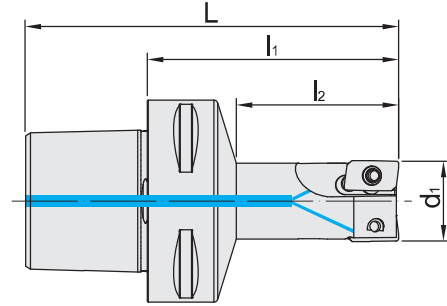



MODEL NO.	TYPE	L	l ₁	l ₂	d ₁	TEETH	INSERT	WEIGHT (KGS)
140.244C.16.050	PSC32 x CIAP16 - 50 - 2T	69	50	25	16	2	AP..1003	0.20
140.244C.20.050	PSC32 x CIAP20 - 50 - 2T	69	50	25	20	2	AP..1003	0.20
140.245C.20.050	PSC32 x CIAP20 - 50 - 3T	69	50	25	20	3	AP..1003	0.30
140.244C.25.050	PSC32 x CIAP25 - 50 - 2T	69	50	32	25	2	AP..1003	0.20
140.245C.25.050	PSC32 x CIAP25 - 50 - 3T	69	50	32	25	3	AP..1003	0.30
140.245C.32.050	PSC32 x CIAP32 - 50 - 3T	69	50	35	32	3	AP..1003	0.20
141.244C.16.050	PSC40 x CIAP16 - 50 - 2T	74	50	25	16	2	AP..1003	0.50
141.244C.20.050	PSC40 x CIAP20 - 50 - 2T	74	50	25	20	2	AP..1003	0.50
141.244C.25.055	PSC40 x CIAP25 - 55 - 2T	79	55	32	25	2	AP..1003	0.50
141.245C.25.055	PSC40 x CIAP25 - 55 - 3T	79	55	32	25	3	AP..1003	0.50
141.245C.32.065	PSC40 x CIAP32 - 65 - 3T	89	65	40	32	3	AP..1003	0.60
142.245C.20.095	PSC50 x CIAP20 - 95 - 3T	125	95	40	20	3	AP..1003	1.00
142.245C.25.095	PSC50 x CIAP25 - 95 - 3T	125	95	45	25	3	AP..1003	1.10
142.245C.32.065	PSC50 x CIAP32 - 65 - 3T	95	65	40	32	3	AP..1003	1.50
142.245C.40.080	PSC50 x CIAP40 - 80 - 3T	110	80	40	40	3	AP..1604	1.10
142.247C.50.060	PSC50 x CIAP50 - 60 - 5T	90	60	60	50	5	AP..1604	1.00
142.247C.63.060	PSC50 x CIAP63 - 60 - 5T	90	60	60	63	5	AP..1604	1.40
143.245C.20.110	PSC63 x CIAP20 - 110 - 3T	148	110	40	20	3	AP..1003	1.60
143.244C.20.165	PSC63 x CIAP20 - 165 - 2T	203	165	60	20	2	AP..1003	1.60
143.245C.25.110	PSC63 x CIAP25 - 110 - 3T	148	110	45	25	3	AP..1003	1.60
143.245C.32.080	PSC63 x CIAP32 - 80 - 3T	118	80	40	32	3	AP..1003	1.50
143.245C.32.110	PSC63 x CIAP32 - 110 - 3T	148	110	50	32	3	AP..1003	1.70
143.246C.40.080	PSC63 x CIAP40 - 80 - 4T	118	80	40	40	4	AP..1003	1.60
143.247C.40.080	PSC63 x CIAP40 - 80 - 5T	118	80	40	40	5	AP..1003	1.60
143.245C.40.100	PSC63 x CIAP40 - 100 - 3T	138	100	50	40	3	AP..1604	1.80
143.246C.50.080	PSC63 x CIAP50 - 80 - 4T	118	80	40	50	4	AP..1604	1.80
143.247C.63.060	PSC63 x CIAP63 - 60 - 5T	98	60	38	63	5	AP..1604	2.20
143.247C.66.060	PSC63 x CIAP66 - 60 - 5T	98	60	60	66	5	AP..1604	1.90
143.247C.66.080	PSC63 x CIAP66 - 80 - 5T	118	80	80	66	5	AP..1604	2.30
143.248C.80.060	PSC63 x CIAP80 - 60 - 6T	98	60	60	80	6	AP..1604	2.20

Product information:

- ▶ One-piece design improves rigidity.
- ▶ Stable insert seat and excellent metal chips removal capacity.
- ▶ Inserts are optional accessories. Needs to be purchased additionally.

ACCESSORIES

Insert	Screw	Wrench
 AP..1003 AP..1604	 M2.5-6.45-3.7-60 M4-10-5.7-60	 T8 T15

PSC / MAP INDEXABLE END MILL CUTTER

PSC / MAP 直角高速銑刀

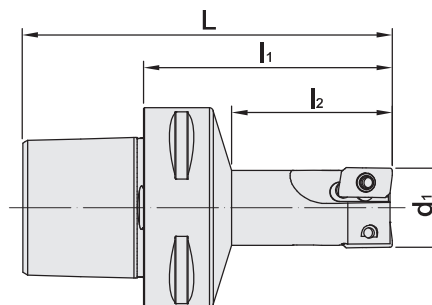



MODEL NO.	TYPE	L	l ₁	l ₂	d ₁	TEETH	INSERT	WEIGHT (KGS)
140.468.16.050	PSC32 x MAP16 - 50 - 2T	69	50	25	16	2	AP.1135	0.20
140.468.20.050	PSC32 x MAP20 - 50 - 2T	69	50	25	20	2	AP.1135	0.20
140.469.20.050	PSC32 x MAP20 - 50 - 3T	69	50	25	20	3	AP.1135	0.30
140.468.25.050	PSC32 x MAP25 - 50 - 2T	69	50	32	25	2	AP.1604	0.20
140.469.25.050	PSC32 x MAP25 - 50 - 3T	69	50	32	25	3	AP.1135	0.30
140.468.32.050	PSC32 x MAP32 - 50 - 2T	69	50	35	32	2	AP.1604	0.20
141.468.16.050	PSC40 x MAP16 - 50 - 2T	74	50	25	16	2	AP.1135	0.50
141.468.20.050	PSC40 x MAP20 - 50 - 2T	74	50	25	20	2	AP.1135	0.50
141.468.25.055	PSC40 x MAP25 - 55 - 2T	79	55	32	25	2	AP.1604	0.50
141.469.25.055	PSC40 x MAP25 - 55 - 3T	79	55	32	25	3	AP.1135	0.50
141.468.32.065	PSC40 x MAP32 - 65 - 2T	89	65	40	32	2	AP.1604	0.60
142.469.20.095	PSC50 x MAP20 - 95 - 3T	125	95	40	20	3	AP.1135	1.00
142.469.25.095	PSC50 x MAP25 - 95 - 3T	125	95	45	25	3	AP.1135	1.10
142.468.32.065	PSC50 x MAP32 - 65 - 2T	95	65	40	32	2	AP.1604	1.50
142.471.50.060	PSC50 x MAP50 - 60 - 5T	90	60	60	50	5	AP.1604	1.00
142.471.63.060	PSC50 x MAP63 - 60 - 5T	90	60	60	63	5	AP.1604	1.40
143.469.20.110	PSC63 x MAP20 - 110 - 3T	148	110	40	20	3	AP.1135	1.60
143.468.20.165	PSC63 x MAP20 - 165 - 2T	203	165	60	20	2	AP.1135	1.60
143.469.25.110	PSC63 x MAP25 - 110 - 3T	148	110	45	25	3	AP.1135	1.60
143.469.32.080	PSC63 x MAP32 - 80 - 3T	118	80	40	32	3	AP.1135	1.50
143.469.32.110	PSC63 x MAP32 - 110 - 3T	148	110	50	32	3	AP.1135	1.70
143.470.40.080	PSC63 x MAP40 - 80 - 4T	118	80	40	40	4	AP.1135	1.60
143.471.40.080	PSC63 x MAP40 - 80 - 5T	118	80	40	40	5	AP.1135	1.60
143.469.40.100	PSC63 x MAP40 - 100 - 3T	138	100	50	40	3	AP.1604	1.80
143.470.50.080	PSC63 x MAP50 - 80 - 4T	118	80	40	50	4	AP.1604	1.80
143.471.63.060	PSC63 x MAP63 - 60 - 5T	98	60	38	63	5	AP.1604	2.20
143.471.66.060	PSC63 x MAP66 - 60 - 5T	98	60	60	66	5	AP.1604	1.90
143.471.66.080	PSC63 x MAP66 - 80 - 5T	118	80	80	66	5	AP.1604	2.30
143.472.80.060	PSC63 x MAP80 - 60 - 6T	98	60	60	80	6	AP.1604	2.20

Product information:

- ▶ One-piece design improves rigidity.
- ▶ Stable insert seat and excellent metal chips removal capacity.
- ▶ Inserts are optional accessories. Needs to be purchased additionally.

ACCESSORIES

Insert	Screw	Wrench
 AP.1135	 M2.5-6.0-3.5-60	 T8
AP.1604	M4-10-5.7-60	T15



PSC / CMAP INDEXABLE END MILL CUTTER

PSC / CMAP 直角高速銑刀

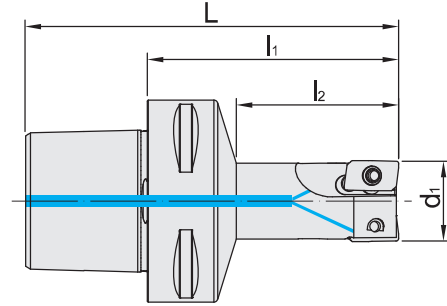



MODEL NO.	TYPE	L	l ₁	l ₂	d ₁	TEETH	INSERT	WEIGHT (KGS)
140.468C.16.050	PSC32 x CMAP16 - 50 - 2T	69	50	25	16	2	AP.1135	0.20
140.468C.20.050	PSC32 x CMAP20 - 50 - 2T	69	50	25	20	2	AP.1135	0.20
140.469C.20.050	PSC32 x CMAP20 - 50 - 3T	69	50	25	20	3	AP.1135	0.30
140.468C.25.050	PSC32 x CMAP25 - 50 - 2T	69	50	32	25	2	AP.1604	0.20
140.469C.25.050	PSC32 x CMAP25 - 50 - 3T	69	50	32	25	3	AP.1135	0.30
140.468C.32.050	PSC32 x CMAP32 - 50 - 2T	69	50	35	32	2	AP.1604	0.20
141.468C.16.050	PSC40 x CMAP16 - 50 - 2T	74	50	25	16	2	AP.1135	0.50
141.468C.20.050	PSC40 x CMAP20 - 50 - 2T	74	50	25	20	2	AP.1135	0.50
141.468C.25.055	PSC40 x CMAP25 - 55 - 2T	79	55	32	25	2	AP.1604	0.50
141.469C.25.055	PSC40 x CMAP25 - 55 - 3T	79	55	32	25	3	AP.1135	0.50
141.468C.32.065	PSC40 x CMAP32 - 65 - 2T	89	65	40	32	2	AP.1604	0.60
142.469C.20.095	PSC50 x CMAP20 - 95 - 3T	125	95	40	20	3	AP.1135	1.00
142.469C.25.095	PSC50 x CMAP25 - 95 - 3T	125	95	45	25	3	AP.1135	1.10
142.468C.32.065	PSC50 x CMAP32 - 65 - 2T	95	65	40	32	2	AP.1604	1.50
142.471C.50.060	PSC50 x CMAP50 - 60 - 5T	90	60	60	50	5	AP.1604	1.00
142.471C.63.060	PSC50 x CMAP63 - 60 - 5T	90	60	60	63	5	AP.1604	1.40
143.469C.20.110	PSC63 x CMAP20 - 110 - 3T	148	110	40	20	3	AP.1135	1.60
143.468C.20.165	PSC63 x CMAP20 - 165 - 2T	203	165	60	20	2	AP.1135	1.60
143.469C.25.110	PSC63 x CMAP25 - 110 - 3T	148	110	45	25	3	AP.1135	1.60
143.469C.32.080	PSC63 x CMAP32 - 80 - 3T	118	80	40	32	3	AP.1135	1.50
143.469C.32.110	PSC63 x CMAP32 - 110 - 3T	148	110	50	32	3	AP.1135	1.70
143.470C.40.080	PSC63 x CMAP40 - 80 - 4T	118	80	40	40	4	AP.1135	1.60
143.471C.40.080	PSC63 x CMAP40 - 80 - 5T	118	80	40	40	5	AP.1135	1.60
143.469C.40.100	PSC63 x CMAP40 - 100 - 3T	138	100	50	40	3	AP.1604	1.80
143.470C.50.080	PSC63 x CMAP50 - 80 - 4T	118	80	40	50	4	AP.1604	1.80
143.471C.63.060	PSC63 x CMAP63 - 60 - 5T	98	60	38	63	5	AP.1604	2.20
143.471C.66.060	PSC63 x CMAP66 - 60 - 5T	98	60	60	66	5	AP.1604	1.90
143.471C.66.080	PSC63 x CMAP66 - 80 - 5T	118	80	80	66	5	AP.1604	2.30
143.472C.80.060	PSC63 x CMAP80 - 60 - 6T	98	60	60	80	6	AP.1604	2.20

Product information:

- ▶ One-piece design improves rigidity.
- ▶ Stable insert seat and excellent metal chips removal capacity.
- ▶ Inserts are optional accessories. Needs to be purchased additionally.

ACCESSORIES

Insert	Screw	Wrench
 AP.1135	 M2.5-6.0-3.5-60	 T8
AP.1604	M4-10-5.7-60	T15

PSC / SPD HIGH SPEED DRILL

ONE-PIECE TYPE

3D

PSC / SPD 一體式快速鑽頭

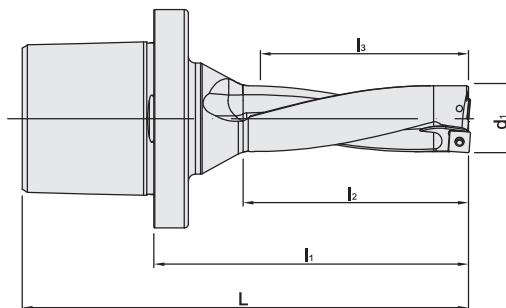

MODEL NO.	TYPE	L	l ₁	l ₂	l ₃	d ₁	INSERT	WEIGHT (KGS)
141.685.15.045	PSC40 x SPD15 - 3D - 45	82	70	50	45	15	SP.0502	0.30
141.685.16.048	PSC40 x SPD16 - 3D - 48	86	74	53	48	16	SP.0602	0.40
141.685.17.051	PSC40 x SPD17 - 3D - 51	89	77	56	51	17	SP.0602	0.42
141.685.18.054	PSC40 x SPD18 - 3D - 54	93	81	59	54	18	SP.0602	0.44
141.685.19.057	PSC40 x SPD19 - 3D - 57	96	84	62	57	19	SP.0602	0.45
141.685.20.060	PSC40 x SPD20 - 3D - 60	101	89	65	60	20	SP.0602	0.47
141.685.21.063	PSC40 x SPD21 - 3D - 63	104	92	68	63	21	SP.0602	0.48
141.685.22.066	PSC40 x SPD22 - 3D - 66	107	95	71	66	22	SP.07T3	0.49
141.685.23.069	PSC40 x SPD23 - 3D - 69	111	99	74	69	23	SP.07T3	0.66
141.685.24.072	PSC40 x SPD24 - 3D - 72	115	103	77	72	24	SP.07T3	0.67
141.685.25.075	PSC40 x SPD25 - 3D - 75	119	107	80	75	25	SP.07T3	0.72
141.685.26.078	PSC40 x SPD26 - 3D - 78	122	110	83	78	26	SP.07T3	0.73
141.685.27.081	PSC40 x SPD27 - 3D - 81	125	113	86	81	27	SP.07T3	0.75
141.685.28.084	PSC40 x SPD28 - 3D - 84	129	117	89	84	28	SP.0904	0.78
141.685.29.087	PSC40 x SPD29 - 3D - 87	132	120	92	87	29	SP.0904	0.81
141.685.30.090	PSC40 x SPD30 - 3D - 90	135	123	95	90	30	SP.0904	0.83

INCHES

MODEL NO.	TYPE	L	l ₁	l ₂	l ₃	d ₁	INSERT	WEIGHT (KGS)
141.685.15.5.047	PSC40 x SPD15.5 - 3D - 47	96	84	52	47	15.5	SP.0602	0.28
141.685.16.5.050	PSC40 x SPD16.5 - 3D - 50	100	88	55	50	16.5	SP.0602	0.31
141.685.17.5.053	PSC40 x SPD17.5 - 3D - 53	104	92	58	53	17.5	SP.0602	0.42
141.685.18.5.056	PSC40 x SPD18.5 - 3D - 56	107	95	61	56	18.5	SP.0602	0.43
141.685.20.62.062	PSC40 x SPD20.62 - 3D - 62	115	103	67	62	20.62	SP.0602	0.43
141.685.22.23.067	PSC40 x SPD22.23 - 3D - 67	120	108	72	67	22.23	SP.07T3	0.45
141.685.25.4.077	PSC40 x SPD25.4 - 3D - 77	133	121	82	77	25.4	SP.07T3	0.48
141.685.28.59.086	PSC40 x SPD28.59 - 3D - 86	143	131	91	86	28.59	SP.0904	0.50

Features:

- ▶ Drilling depth is three times longer than the diameter of the High Speed Drill. ▶ The material is anti-vibration tool steel.
- ▶ The whole body is treated with fine grinding after hardening in order to raise the rigidity and stability and prevent from deformation.
- ▶ There is special coating on the surface of the high speed drill, which decreases the wear rate and extends the use life of the drill.

Product information:

- ▶ Inserts are optional accessories. Needs to be purchased additionally.

ACCESSORIES

Insert	Screw	Wrench
SP.0502	M2-4.3-2.7-60	T6
SP.0602	M2.2-5.2-3.1-60	T7
SP.07T3	M2.5-6.33-3.5-48	T8
SP.0904	M3.5-8.4-5.0-60	T10



PSC / SPD HIGH SPEED DRILL

ONE-PIECE TYPE

4D

PSC / SPD 一體式快速鑽頭

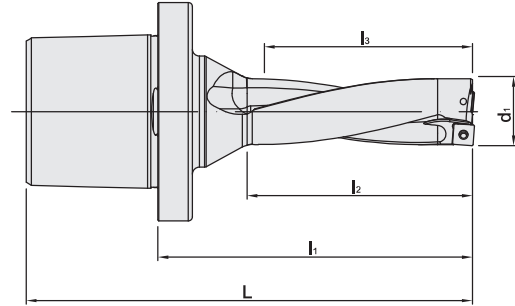

MODEL NO.	TYPE	L	l ₁	l ₂	l ₃	d ₁	INSERT	WEIGHT (KGS)
141.685.17.068	PSC40 x SPD17 - 4D - 68	118	106	73	68	17	SP..0602	0.45
141.685.18.072	PSC40 x SPD18 - 4D - 72	123	111	77	72	18	SP..0602	0.47
141.685.19.076	PSC40 x SPD19 - 4D - 76	127	115	81	76	19	SP..0602	0.48
141.685.20.080	PSC40 x SPD20 - 4D - 80	133	121	85	80	20	SP..0602	0.50
141.685.21.084	PSC40 x SPD21 - 4D - 84	137	125	89	84	21	SP..0602	0.51
141.685.22.088	PSC40 x SPD22 - 4D - 88	141	129	93	88	22	SP..07T3	0.74
141.685.23.092	PSC40 x SPD23 - 4D - 92	146	134	97	92	23	SP..07T3	0.56
141.685.24.096	PSC40 x SPD24 - 4D - 96	151	139	101	96	24	SP..07T3	0.58
141.685.25.100	PSC40 x SPD25 - 4D - 100	156	144	105	100	25	SP..07T3	0.61
141.685.26.104	PSC40 x SPD26 - 4D - 104	160	148	109	104	26	SP..07T3	0.65
141.685.27.108	PSC40 x SPD27 - 4D - 108	164	152	113	108	27	SP..07T3	0.69
141.685.28.112	PSC40 x SPD28 - 4D - 112	169	157	117	112	28	SP..0904	0.73
141.685.29.116	PSC40 x SPD29 - 4D - 116	173	161	121	116	29	SP..0904	0.75
141.685.30.120	PSC40 x SPD30 - 4D - 120	177	165	125	120	30	SP..0904	0.81

INCHES

MODEL NO.	TYPE	L	l ₁	l ₂	l ₃	d ₁	INSERT	WEIGHT (KGS)
141.685.17.5.070	PSC40 x SPD17.5 - 4D - 70	121	109	75	70	17.5	SP..0602	0.47
141.685.18.5.074	PSC40 x SPD18.5 - 4D - 74	125	113	79	74	18.5	SP..0602	0.49
141.685.20.62.083	PSC40 x SPD20.62 - 4D - 83	136	124	88	83	20.62	SP..0602	0.52
141.685.22.23.089	PSC40 x SPD22.23 - 4D - 89	142	130	94	89	22.23	SP..07T3	0.76
141.685.25.4.102	PSC40 x SPD25.4 - 4D - 102	158	146	107	102	25.4	SP..07T3	0.63
141.685.28.59.115	PSC40 x SPD28.59 - 4D - 115	172	160	120	115	28.59	SP..0904	0.75



Features:

- ▶ Drilling depth is four times longer than the diameter of the High Speed Drill. ▶ The material is anti-vibration tool steel.
- ▶ The whole body is treated with fine grinding after hardening in order to raise the rigidity and stability and prevent from deformation.
- ▶ There is special coating on the surface of the high speed drill, which decreases the wear rate and extends the use life of the drill.

Product information:

- ▶ Inserts are optional accessories. Needs to be purchased additionally.

ACCESSORIES

Insert	Screw	Wrench
		
SP.0502	M2-4.3-2.7-60	T6
SP.0602	M2.2-5.2-3.1-60	T7
SP.07T3	M2.5-6.33-3.5-48	T8
SP.0904	M3.5-8.4-5.0-60	T10

PSC / PNER COLLET CHUCK



PSC / PNER 立銑刀夾頭



台灣精品 2012
TAIWAN EXCELLENCE



台灣精品 2017
TAIWAN EXCELLENCE



T W PAT NO. M298033
T W PAT NO. M311791
T W PAT NO. M501316
J P PAT NO. 3128766
J P PAT NO. 3200356
K R PAT NO. 20-0433603
C N PAT NO. ZL200620132661.0
C H PAT NO. 696550
T R PAT NO. TR 2007 02942 Y
I T PAT NO. N.0000266731
D E PAT NO. Nr.202015005621

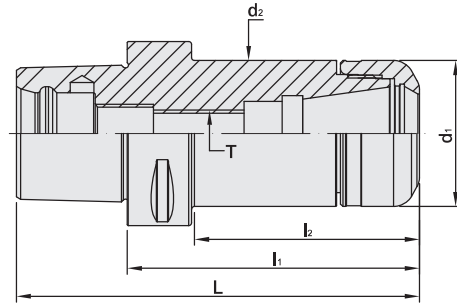

MODEL NO.	TYPE	L	l ₁	l ₂	d ₁	d ₂	T	SIZE RANGE	WEIGHT (KGS)
140.273.16.045	PSC32 x PNER16 - 45	64	45	29	30	30	-	3 ~ 10	0.21
140.273.20.045	PSC32 x PNER20 - 45	64	45	30	32	32	-	3 ~ 13	0.21
141.273.16.055	PSC40 x PNER16 - 55	79	55	30	30	30	-	3 ~ 10	0.36
141.273.20.055	PSC40 x PNER20 - 55	79	55	31	32	32	-	3 ~ 13	0.36
142.273.16.060	PSC50 x PNER16 - 60	90	60	34	30	30	-	3 ~ 10	0.56
142.273.16.100	PSC50 x PNER16 - 100	130	100	74	30	30	M10 x 1.5P	3 ~ 10	0.75
142.273.20.060	PSC50 x PNER20 - 60	90	60	34	32	32	-	3 ~ 13	0.57
142.273.25.060	PSC50 x PNER25 - 60	90	60	37	40	40	-	3 ~ 16	0.63
142.273.32.060	PSC50 x PNER32 - 60	90	60	37	50	50	-	3 ~ 20	0.70
143.273.16.060	PSC63 x PNER16 - 60	98	60	35	30	30	-	3 ~ 10	0.87
143.273.16.100	PSC63 x PNER16 - 100	138	100	75	30	30	M10 x 1.5P	3 ~ 10	1.07
143.273.20.060	PSC63 x PNER20 - 60	98	60	35	32	32	-	3 ~ 13	0.88
143.273.20.100	PSC63 x PNER20 - 100	138	100	75	32	32	M12 x 1.75P	3 ~ 13	1.10
143.273.25.060	PSC63 x PNER25 - 60	98	60	35	40	40	-	3 ~ 16	0.94
143.273.25.100	PSC63 x PNER25 - 100	138	100	75	40	40	M16 x 2.0P	3 ~ 16	1.28
143.273.25.130	PSC63 x PNER25 - 130	168	130	105	40	40	M16 x 2.0P	3 ~ 16	1.53
143.273.25.160	PSC63 x PNER25 - 160	198	160	135	40	40	M16 x 2.0P	3 ~ 16	1.79
143.273.32.060	PSC63 x PNER32 - 60	98	60	35	50	50	-	3 ~ 20	1.00
143.273.32.100	PSC63 x PNER32 - 100	138	100	75	50	50	M16 x 2.0P	3 ~ 20	1.55
143.273.32.130	PSC63 x PNER32 - 130	168	130	105	50	50	M16 x 2.0P	3 ~ 20	1.97
143.273.40.060	PSC63 x PNER40 - 60	98	60	38	63	63	-	6 ~ 26	1.18
143.273.40.100	PSC63 x PNER40 - 100	138	100	68	63	63	M20 x 2.0P	6 ~ 26	2.03
144.273.32.100	PSC80 x PNER32 - 100	148	100	65	50	50	M16 x 2.0P	3 ~ 20	2.38
144.273.40.100	PSC80 x PNER40 - 100	148	100	69	63	63	M20 x 2.0P	6 ~ 26	2.73

Product information:

- ▶ Balance: G2.5 25,000 rpm. Higher balancing grade and revolution can be done upon request but additional charge is needed.
- ▶ Use PNER 3µm collet.

Standard Accessory: • NUT

Collet	Nut	Coolant Supply unit	Preset Screw	Spanner
P.W-4	P.W-39	P.W-60	P.W-82	P.W-62~67



PSC / PTER COLLET CHUCK



PSC / PTER 立銑刀夾頭



台灣精品 2012
TAIWAN EXCELLENCE



T W PAT NO. M298033
T W PAT NO. M311791
J P PAT NO. 3128766
J P PAT NO. 3200356
K R PAT NO. 20-0433603
C N PAT NO. ZL200620132661.0
C H PAT NO. 696550
T R PAT NO. TR.2007.02942 Y
I T PAT NO. N.0000266731

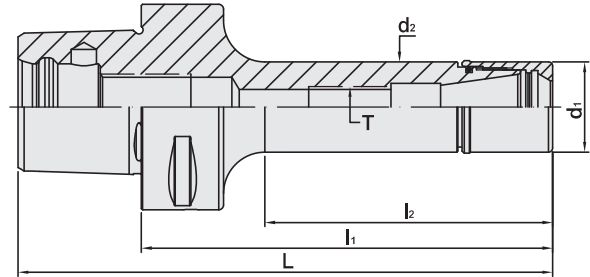

MODEL NO.	TYPE	L	l ₁	l ₂	d ₁	d ₂	T	SIZE RANGE	WEIGHT (KGS)
140.528.16.040	PSC32 x PTER16 - 40	59	40	24	22	22	-	3 - 10	0.15
140.528.16.050	PSC32 x PTER16 - 50	69	50	34	22	22	-	3 - 10	0.18
140.528.20.050	PSC32 x PTER20 - 50	69	50	33	28	28	-	3 - 13	0.21
140.528.25.065	PSC32 x PTER25 - 65	84	65	49	35	34	-	3 - 16	0.32
141.528.16.050	PSC40 x PTER16 - 50	74	50	29	22	22	-	3 - 10	0.30
141.528.20.050	PSC40 x PTER20 - 50	74	50	29	28	28	-	3 - 13	0.30
141.528.25.065	PSC40 x PTER25 - 65	89	65	42	35	34	-	3 - 16	0.41
142.528.11.070	PSC50 x PTER11 - 70	100	70	40	16	16	M6 x 1.0P	3 - 7	0.49
142.528.11.100	PSC50 x PTER11 - 100	130	100	70	16	16	M6 x 1.0P	3 - 7	0.52
142.528.11.125	PSC50 x PTER11 - 125	155	125	95	16	16	M6 x 1.0P	3 - 7	0.55
142.528.11.150	PSC50 x PTER11 - 150	180	150	120	16	16	M6 x 1.0P	3 - 7	0.59
142.528.16.070	PSC50 x PTER16 - 70	100	70	40	22	22	-	3 - 10	0.52
142.528.16.100	PSC50 x PTER16 - 100	130	100	70	22	22	M10 x 1.5P	3 - 10	0.60
142.528.16.125	PSC50 x PTER16 - 125	155	125	95	22	22	M10 x 1.5P	3 - 10	0.66
142.528.16.150	PSC50 x PTER16 - 150	180	150	120	22	22	M10 x 1.5P	3 - 10	0.72
142.528.20.070	PSC50 x PTER20 - 70	100	70	45	28	28	-	3 - 13	0.57
142.528.20.100	PSC50 x PTER20 - 100	130	100	75	28	28	M12 x 1.75P	3 - 13	0.68
142.528.20.125	PSC50 x PTER20 - 125	155	125	100	28	28	M12 x 1.75P	3 - 13	0.79
142.528.20.150	PSC50 x PTER20 - 150	180	150	125	28	28	M12 x 1.75P	3 - 13	0.89

Product information:

- ▶ Balance: G2.5 25,000 rpm. Higher balancing grade and revolution can be done upon request but additional charge is needed.
- ▶ Use PNER-U 5µm collet.

Standard Accessory: • NUT

Collet	Nut	Coolant Supply unit	Preset Screw	Spanner
P.W-4	P.W-41	P.W-60	P.W-82	P.W-62~67

PSC / PTER COLLET CHUCK



PSC / PTER 立銑刀夾頭



T W PAT NO. M298033
 T W PAT NO. M311791
 J P PAT NO. 3128766
 J P PAT NO. 3200356
 K R PAT NO. 20-0433603
 C N PAT NO. ZL200620132661.0
 C H PAT NO. 696550
 T R PAT NO. TR.2007.02942 Y
 I T PAT NO. N.0000266731

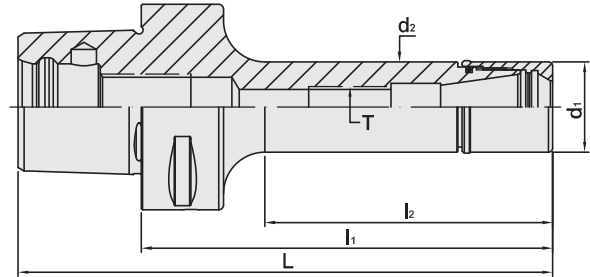

MODEL NO.	TYPE	L	l ₁	l ₂	d ₁	d ₂	T	SIZE RANGE	WEIGHT (KGS)
143.528.11.070	PSC63 x PTER11 - 70	108	70	43	16	16	M6 x 1.0P	3 ~ 7	0.79
143.528.11.100	PSC63 x PTER11 - 100	138	100	68	16	16	M6 x 1.0P	3 ~ 7	0.84
143.528.11.125	PSC63 x PTER11 - 125	163	125	88	16	16	M6 x 1.0P	3 ~ 7	0.89
143.528.11.150	PSC63 x PTER11 - 150	188	150	113	16	16	M6 x 1.0P	3 ~ 7	0.93
143.528.16.070	PSC63 x PTER16 - 70	108	70	38	22	22	-	3 ~ 10	0.84
143.528.16.100	PSC63 x PTER16 - 100	138	100	68	22	22	M10 x 1.5P	3 ~ 10	0.92
143.528.16.125	PSC63 x PTER16 - 125	163	125	93	22	22	M10 x 1.5P	3 ~ 10	0.98
143.528.16.150	PSC63 x PTER16 - 150	188	150	118	22	22	M10 x 1.5P	3 ~ 10	1.04
143.528.20.070	PSC63 x PTER20 - 70	108	70	38	28	28	-	3 ~ 13	0.89
143.528.20.100	PSC63 x PTER20 - 100	138	100	68	28	28	M12 x 1.75P	3 ~ 13	1.00
143.528.20.125	PSC63 x PTER20 - 125	163	125	93	28	28	M12 x 1.75P	3 ~ 13	1.12
143.528.20.150	PSC63 x PTER20 - 150	188	150	118	28	28	M12 x 1.75P	3 ~ 13	1.22

Product information:

- ▶ Balance: G2.5 25,000 rpm. Higher balancing grade and revolution can be done upon request but additional charge is needed.
- ▶ Use PNER-U 5µm collet.

Standard Accessory: • NUT

Collet	Nut	Coolant Supply unit	Preset Screw	Spanner
P.W-4	P.W-41	P.W-60	P.W-82	P.W-62~67



PSC / UT COLLET CHUCK



PSC / UT 立銑刀夾頭



T W PAT NO. M298033
 T W PAT NO. M311791
 J P PAT NO. 3128766
 K R PAT NO. 20-0433603
 C N PAT NO. ZL200620132661.0
 C H PAT NO. 696550
 T R PAT NO. TR 2007 02942 Y
 I T PAT NO. N.0000266731

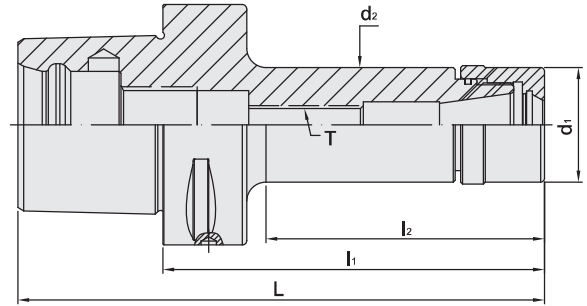

MODEL NO.	TYPE	L	l ₁	l ₂	d ₁	d ₂	T	SIZE RANGE	WEIGHT (KGS)
140.753.16.045	PSC32 x UT16 - 45	64	45	29	30	30	-	1 ~ 10	0.23
141.753.16.070	PSC40 x UT16 - 70	94	70	47	30	30	M10 x 1.5P	1 ~ 10	0.46
141.753.20.052	PSC40 x UT20 - 52	76	52	31.2	35	36	-	1 ~ 13	0.40
141.753.25.055	PSC40 x UT25 - 55	79	55	35	42	42	-	1 ~ 16	0.70
141.753.32.060	PSC40 x UT32 - 60	84	60	40	48	48	-	2 ~ 20	0.80
142.753.16.100	PSC50 x UT16 - 100	130	100	75	30	30	M10 x 1.5P	1 ~ 10	0.78
142.753.16.130	PSC50 x UT16 - 130	160	130	105	30	30	M10 x 1.5P	1 ~ 10	0.90
142.753.20.055	PSC50 x UT20 - 55	85	55	32	35	36	-	1 ~ 13	0.60
142.753.20.100	PSC50 x UT20 - 100	130	100	77	35	36	M12 x 1.75P	1 ~ 13	0.91
142.753.20.130	PSC50 x UT20 - 130	160	130	107	35	36	M12 x 1.75P	1 ~ 13	1.10
142.753.25.060	PSC50 x UT25 - 60	90	60	39	42	42	-	1 ~ 16	0.70
142.753.25.100	PSC50 x UT25 - 100	130	100	79	42	42	M16 x 2.0P	1 ~ 16	1.10
142.753.25.130	PSC50 x UT25 - 130	160	130	109	42	42	M16 x 2.0P	1 ~ 16	1.40
142.753.32.057	PSC50 x UT32 - 57	87	57	36	48	48	-	2 ~ 20	0.70
142.753.32.100	PSC50 x UT32 - 100	130	100	79	48	48	M16 x 2.0P	2 ~ 20	1.18

Product information:

- ▶ Balance: G2.5 25,000 rpm. Higher balancing grade and revolution can be done upon request but additional charge is needed.
- ▶ Use standard ER collets.

Standard Accessory: • NUT

Collet	Nut	Coolant Supply unit	Preset Screw	Spanner
P.W-6~9	P.W-41	P.W-60	P.W-82	P.W-62~67

PSC / UT COLLET CHUCK



PSC / UT 立銑刀夾頭



T W PAT NO. M298033
 T W PAT NO. M311791
 J P PAT NO. 3128766
 K R PAT NO. 20-0433603
 C N PAT NO. ZL200620132661.0
 C H PAT NO. 696550
 T R PAT NO. TR 2007 02942 Y
 I T PAT NO. N.0000266731

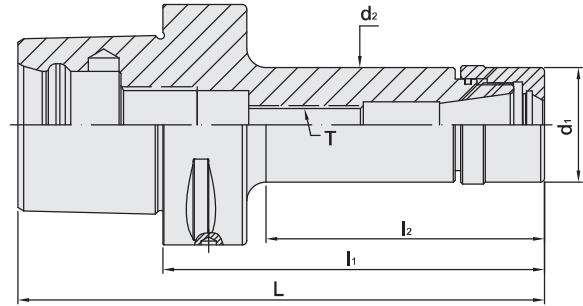

MODEL NO.	TYPE	L	l ₁	l ₂	d ₁	d ₂	T	SIZE RANGE	WEIGHT (KGS)
143.753.16.100	PSC63 x UT16 - 100	138	100	73	30	30	M10 x 1.5P	1 ~ 10	1.09
143.753.16.130	PSC63 x UT16 - 130	168	130	103	30	30	M10 x 1.5P	1 ~ 10	1.19
143.753.16.160	PSC63 x UT16 - 160	198	160	133	30	30	M10 x 1.5P	1 ~ 10	1.30
143.753.20.060	PSC63 x UT20 - 60	98	60	33	35	36	-	1 ~ 13	0.95
143.753.20.100	PSC63 x UT20 - 100	138	100	70	35	36	M12 x 1.75P	1 ~ 13	1.23
143.753.20.130	PSC63 x UT20 - 130	168	130	100	35	36	M12 x 1.75P	1 ~ 13	1.41
143.753.20.160	PSC63 x UT20 - 160	198	160	130	35	36	M12 x 1.75P	1 ~ 13	1.58
143.753.25.065	PSC63 x UT25 - 65	103	65	38	42	42	-	1 ~ 16	0.95
143.753.25.100	PSC63 x UT25 - 100	138	100	73	42	42	M16 x 2.0P	1 ~ 16	1.25
143.753.25.130	PSC63 x UT25 - 130	168	130	103	42	42	M16 x 2.0P	1 ~ 16	1.54
143.753.25.160	PSC63 x UT25 - 160	198	160	133	42	42	M16 x 2.0P	1 ~ 16	1.82
143.753.32.070	PSC63 x UT32 - 70	108	70	43	48	48	-	2 ~ 20	1.15
143.753.32.100	PSC63 x UT32 - 100	138	100	73	48	48	M16 x 2.0P	2 ~ 20	1.48
143.753.32.130	PSC63 x UT32 - 130	168	130	103	48	48	M16 x 2.0P	2 ~ 20	1.87
143.753.32.160	PSC63 x UT32 - 160	198	160	133	48	48	M16 x 2.0P	2 ~ 20	2.23
144.753.16.070	PSC80 x UT16 - 70	118	70	35	30	30	-	1 ~ 10	2.10
144.753.16.100	PSC80 x UT16 - 100	148	100	65	30	30	M10 x 1.5P	1 ~ 10	2.70
144.753.16.160	PSC80 x UT16 - 160	208	160	120	30	30	M10 x 1.5P	1 ~ 10	2.90
144.753.20.070	PSC80 x UT20 - 70	118	70	35	35	35	-	1 ~ 13	2.60
144.753.20.100	PSC80 x UT20 - 100	148	100	65	35	35	M12 x 1.75P	1 ~ 13	2.90
144.753.20.160	PSC80 x UT20 - 160	208	160	120	35	35	M12 x 1.75P	1 ~ 13	3.20
144.753.25.070	PSC80 x UT25 - 70	118	70	35	42	42	-	1 ~ 16	2.70
144.753.25.100	PSC80 x UT25 - 100	148	100	65	42	42	M16 x 2.0P	1 ~ 16	2.90
144.753.25.160	PSC80 x UT25 - 160	208	160	120	42	42	M16 x 2.0P	1 ~ 16	3.50
144.753.32.070	PSC80 x UT32 - 70	118	70	39	48	48	-	2 ~ 20	1.96
144.753.32.100	PSC80 x UT32 - 100	148	100	65	48	48	M16 x 2.0P	2 ~ 20	2.32
144.753.32.160	PSC80 x UT32 - 160	208	160	125	48	48	M16 x 2.0P	2 ~ 20	3.06

Product information:

- ▶ Balance: G2.5 25,000 rpm. Higher balancing grade and revolution can be done upon request but additional charge is needed.
- ▶ Use standard ER collets.

Standard Accessory: • NUT

Collet	Nut	Coolant Supply unit	Preset Screw	Spanner
P.W-6~9	P.W-41	P.W-60	P.W-82	P.W-62~67



PSC / ER COLLET CHUCK



PSC / ER 立銑刀夾頭



T W PAT NO. M298033
 T W PAT NO. M311791
 J P PAT NO. 3128766
 K R PAT NO. 20-0433603
 C N PAT NO. ZL200620132661.0
 C H PAT NO. 696550
 T R PAT NO. TR 2007 02942 Y
 I T PAT NO. N.0000266731

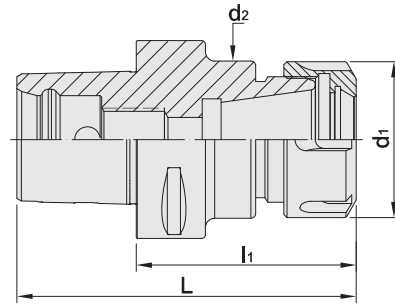

MODEL NO.	TYPE	L	l ₁	d ₁	d ₂	SIZE RANGE	WEIGHT (KGS)
140.122.16.045	PSC32 x ER16A - 45	64	45	28	28	1 ~ 10	0.20
140.122.20.045	PSC32 x ER20A - 45	64	45	34	34	1 ~ 13	0.30
141.122.16.070	PSC40 x ER16A - 70	94	70	28	28	1 ~ 10	0.40
141.122.20.052	PSC40 x ER20A - 52	76	52	34	34	1 ~ 13	0.30
141.122.25.052	PSC40 x ER25 - 52	76	52	42	42	1 ~ 16	0.40
141.122.32.054	PSC40 x ER32 - 54	78	54	50	50	2 ~ 20	0.50
142.122.16.100	PSC50 x ER16A - 100	130	100	28	28	1 ~ 10	0.90
142.122.20.055	PSC50 x ER20A - 55	85	55	34	34	1 ~ 13	0.50
142.122.20.100	PSC50 x ER20A - 100	130	100	34	34	1 ~ 13	0.80
142.122.25.055	PSC50 x ER25 - 55	85	55	42	42	1 ~ 16	0.50
142.122.32.057	PSC50 x ER32 - 57	87	57	50	50	2 ~ 20	0.60
142.122.32.100	PSC50 x ER32 - 100	130	100	50	50	2 ~ 20	0.90
143.122.16.100	PSC63 x ER16A - 100	138	100	28	28	1 ~ 10	1.30
143.122.20.060	PSC63 x ER20A - 60	98	60	34	34	1 ~ 13	0.80
143.122.20.100	PSC63 x ER20A - 100	138	100	34	34	1 ~ 13	1.29
143.122.25.060	PSC63 x ER25 - 60	98	60	42	42	1 ~ 16	0.90
143.122.25.100	PSC63 x ER25 - 100	138	100	42	42	1 ~ 16	1.30
143.122.32.070	PSC63 x ER32 - 70	108	70	50	50	2 ~ 20	0.80
143.122.32.100	PSC63 x ER32 - 100	138	100	50	50	2 ~ 20	1.50
143.122.40.065	PSC63 x ER40 - 65	103	65	63	63	3 ~ 26	1.10
144.122.20.065	PSC80 x ER20A - 65	113	65	34	34	1 ~ 13	1.40
144.122.25.070	PSC80 x ER25 - 70	118	70	42	42	1 ~ 16	1.60
144.122.32.070	PSC80 x ER32 - 70	118	70	50	50	2 ~ 20	1.80
144.122.32.160	PSC80 x ER32 - 160	208	160	50	50	2 ~ 20	2.00
144.122.40.070	PSC80 x ER40 - 70	118	70	63	63	3 ~ 26	2.30
144.122.40.160	PSC80 x ER40 - 160	208	160	63	63	3 ~ 26	4.10
144.122.50.080	PSC80 x ER50 - 80	128	80	78	78	6 ~ 34	4.60

Product information:

- ▶ Balance: G2.5 25,000 rpm. Higher balancing grade and revolution can be done upon request but additional charge is needed.

Standard Accessory: • NUT

Collet	Nut	Coolant Supply unit	Preset Screw	Spanner
P.W-6~24	P.W-42	P.W-60	P.W-82	P.W-62~65

PSC / SKX COLLET CHUCK

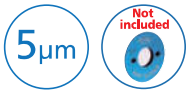

PSC / SKX 立銑刀夾頭

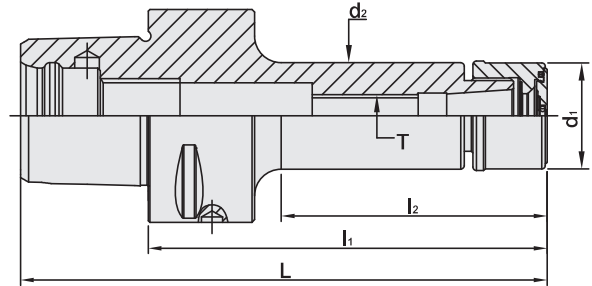

MODEL NO.	TYPE	L	l ₁	l ₂	d ₁	d ₂	T	SIZE RANGE	WEIGHT (KGS)
141.790.06.060	PSC40 x SKX6 - 60	84	60	35	18	18	M8 x 1.25P	3 ~ 6	0.28
141.790.10.075	PSC40 x SKX10 - 75	99	75	50	30	30	M12 x 1.75P	3 ~ 10	0.43
141.790.16.080	PSC40 x SKX16 - 80	104	80	55	40	40	M18 x 1.5P	3 ~ 16	0.54
142.790.06.060	PSC50 x SKX6 - 60	90	60	35	18	18	M8 x 1.25P	3 ~ 6	0.45
142.790.06.080	PSC50 x SKX6 - 80	110	80	55	18	18	M8 x 1.25P	3 ~ 6	0.52
142.790.10.060	PSC50 x SKX10 - 60	90	60	35	30	30	M12 x 1.75P	3 ~ 10	0.53
142.790.10.090	PSC50 x SKX10 - 90	120	90	65	30	30	M12 x 1.75P	3 ~ 10	0.63
142.790.16.080	PSC50 x SKX16 - 80	110	80	55	40	40	M18 x 1.5P	3 ~ 16	0.72
142.790.16.105	PSC50 x SKX16 - 105	135	105	80	40	40	M18 x 1.5P	3 ~ 16	1.27
143.790.06.060	PSC63 x SKX6 - 60	98	60	33	18	18	M8 x 1.25P	3 ~ 6	0.81
143.790.06.100	PSC63 x SKX6 - 100	138	100	73	18	18	M8 x 1.25P	3 ~ 6	0.88
143.790.06.120	PSC63 x SKX6 - 120	158	120	93	18	18	M8 x 1.25P	3 ~ 6	0.92
143.790.10.060	PSC63 x SKX10 - 60	98	60	33	30	30	M12 x 1.75P	3 ~ 10	0.87
143.790.10.105	PSC63 x SKX10 - 105	143	105	78	30	30	M12 x 1.75P	3 ~ 10	1.12
143.790.10.120	PSC63 x SKX10 - 120	158	120	93	30	30	M12 x 1.75P	3 ~ 10	1.19
143.790.16.080	PSC63 x SKX16 - 80	118	80	53	40	40	-	3 ~ 16	1.06
143.790.16.105	PSC63 x SKX16 - 105	143	105	83	40	40	M18 x 1.5P	3 ~ 16	1.28
143.790.16.120	PSC63 x SKX16 - 120	158	120	98	40	40	M18 x 1.5P	3 ~ 16	1.41
143.790.20.090	PSC63 x SKX20 - 90	128	90	60	48.5	48.5	-	3 ~ 20	1.32
143.790.20.105	PSC63 x SKX20 - 105	143	105	80	48.5	48.5	M22 x 1.5P	3 ~ 20	1.48
143.790.20.135	PSC63 x SKX20 - 135	173	135	95	48.5	48.5	M22 x 1.5P	3 ~ 20	1.80
143.790.25.090	PSC63 x SKX25 - 90	128	90	65	55	55	-	3 ~ 25.4	1.32
143.790.25.135	PSC63 x SKX25 - 135	173	135	110	55	55	M22 x 1.5P	3 ~ 25.4	1.82
144.790.10.075	PSC80 x SKX10 - 75	123	75	22	30	30	M28 x 2.0P	3 ~ 10	1.84
144.790.10.090	PSC80 x SKX10 - 90	138	90	42	30	30	-	3 ~ 10	1.91
144.790.16.075	PSC80 x SKX16 - 75	123	75	37	40	40	M12 x 1.75P	3 ~ 16	1.89
144.790.16.090	PSC80 x SKX16 - 90	138	90	57	40	40	M18 x 1.5P	3 ~ 16	2.01

Features:

- ▶ SKX sealed cap is optional. Please order SKX sealed cap additionally.
- ▶ With the design of SKX sealed cap, coolant pressure capable up to 70 bar.
- ▶ Used with coolant-through tools.
- ▶ Balance: G2.5 25,000rpm.

Standard Accessory: • NUT

Collet	Nut	Cap	Coolant Supply unit	Preset Screw	Spanner	Sealed Cap Spanner
P.W-25	P.W-49	P.W-50	P.W-60	P.W-82	P.W-62~67	P.W-66



PSC / SK3 COLLET CHUCK

5 μ m

PSC / SK3 高速機專用夾頭

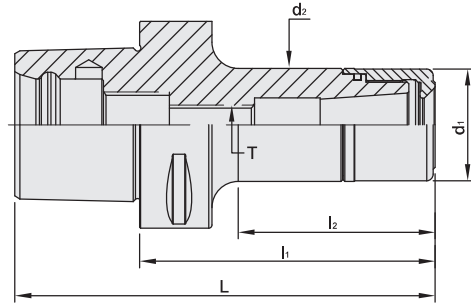

台灣精品 2012
TAWAN EXCELLENCE

MODEL NO.	TYPE	L	l ₁	l ₂	d ₁	d ₂	T	SIZE RANGE	WEIGHT (KGS)
141.763.06.075	PSC40 x SK306 - 75	99	75	48	19.5	19.5	M8 x 1.25P	3 ~ 6	0.20
141.763.10.075	PSC40 x SK310 - 75	99	75	28	27.5	27.5	M12 x 1.75P	3 ~ 10	0.20
141.763.13.075	PSC40 x SK313 - 75	99	75	54	33	33	M12 x 1.75P	3 ~ 13	0.30
142.763.06.060	PSC50 x SK306 - 60	90	60	34	19.5	19.5	M8 x 1.25P	3 ~ 6	0.50
142.763.06.075	PSC50 x SK306 - 75	105	75	49	19.5	19.5	M8 x 1.25P	3 ~ 6	0.60
142.763.06.090	PSC50 x SK306 - 90	120	90	62	19.5	19.5	M8 x 1.25P	3 ~ 6	0.70
142.763.10.075	PSC50 x SK310 - 75	105	75	49	27.5	27.5	M12 x 1.75P	3 ~ 10	0.70
142.763.10.090	PSC50 x SK310 - 90	120	90	64	27.5	27.5	M12 x 1.75P	3 ~ 10	0.80
142.763.13.075	PSC50 x SK313 - 75	105	75	49	33	33	M12 x 1.75P	3 ~ 13	0.70
142.763.13.090	PSC50 x SK313 - 90	120	90	64	33	33	M12 x 1.75P	3 ~ 13	0.90
142.763.16.075	PSC50 x SK316 - 75	105	75	53	40	40	M18 x 1.5P	3 ~ 16	0.90
142.763.16.090	PSC50 x SK316 - 90	120	90	69	40	40	M18 x 1.5P	3 ~ 16	1.10
143.763.06.060	PSC63 x SK306 - 60	98	60	30	19.5	19.5	M8 x 1.25P	3 ~ 6	0.80
143.763.06.075	PSC63 x SK306 - 75	113	75	43	19.5	19.5	M8 x 1.25P	3 ~ 6	0.90
143.763.06.090	PSC63 x SK306 - 90	128	90	58	19.5	19.5	M8 x 1.25P	3 ~ 6	1.00
143.763.10.075	PSC63 x SK310 - 75	98	75	43	27.5	27.5	M12 x 1.75P	3 ~ 10	0.90
143.763.10.090	PSC63 x SK310 - 90	128	90	58	27.5	27.5	M12 x 1.75P	3 ~ 10	1.10
143.763.13.075	PSC63 x SK313 - 75	98	75	45	33	33	M12 x 1.75P	3 ~ 13	1.00
143.763.13.090	PSC63 x SK313 - 90	128	90	60	33	33	M12 x 1.75P	3 ~ 13	1.20
143.763.16.075	PSC63 x SK316 - 75	98	75	47	40	40	M18 x 1.5P	3 ~ 16	1.10
143.763.16.090	PSC63 x SK316 - 90	128	90	60	40	40	M18 x 1.5P	3 ~ 16	1.30
144.763.06.060	PSC80 x SK306 - 60	108	60	27	19.5	19.5	M8 x 1.25P	3 ~ 6	1.80
144.763.06.075	PSC80 x SK306 - 75	123	75	42	19.5	19.5	M8 x 1.25P	3 ~ 6	1.90
144.763.06.090	PSC80 x SK306 - 90	138	90	57	19.5	19.5	M8 x 1.25P	3 ~ 6	2.00
144.763.10.075	PSC80 x SK310 - 75	123	75	42	27.5	27.5	M12 x 1.75P	3 ~ 10	2.10
144.763.10.090	PSC80 x SK310 - 90	138	90	57	27.5	27.5	M12 x 1.75P	3 ~ 10	2.20
144.763.13.075	PSC80 x SK313 - 75	123	75	42	33	33	M12 x 1.75P	3 ~ 13	2.10
144.763.13.090	PSC80 x SK313 - 90	138	90	57	33	33	M12 x 1.75P	3 ~ 13	2.30
144.763.16.075	PSC80 x SK316 - 75	123	75	42	40	40	M18 x 1.5P	3 ~ 16	2.20
144.763.16.090	PSC80 x SK316 - 90	138	90	57	40	40	M18 x 1.5P	3 ~ 16	2.40

Product information:

- ▶ Balance: G2.5 25,000 rpm. Higher balancing grade and revolution can be done upon request but additional charge is needed.
- ▶ Patent number: TW PAT NO. M270871.

Standard Accessory: • NUT

Collet	Nut	Coolant Supply unit	Preset Screw	Spanner
				
P.W-25~28	P.W-46	P.W-60	P.W-82	P.W-62~67

PSC / SKS COLLET CHUCK

5 μ m

PSC / SKS 高速機專用夾頭



台灣精品 2012
TAIWAN EXCELLENCE

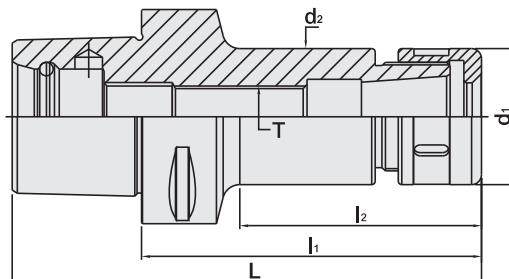

T W PAT NO. M270871

MODEL NO.	TYPE	L	l ₁	l ₂	d ₁	d ₂	T	SIZE RANGE	WEIGHT (KGS)
140.658.06.045	PSC32 x SKS6 - 45	64	45	28	18	18	M8 x 1.25P	3 ~ 6	0.20
140.658.10.045	PSC32 x SKS10 - 45	64	45	29	30	30	-	3 ~ 10	0.20
141.658.06.050	PSC40 x SKS6 - 50	74	50	28	18	18	M8 x 1.25P	3 ~ 6	0.50
141.658.10.050	PSC40 x SKS10 - 50	74	50	28	30	30	-	3 ~ 10	0.60
141.658.13.050	PSC40 x SKS13 - 50	74	50	29	35	33	-	3 ~ 13	0.70
141.658.16.050	PSC40 x SKS16 - 50	74	50	31.3	40	40	-	3 ~ 16	0.80
142.658.06.060	PSC50 x SKS6 - 60	90	60	35	18	18	M8 x 1.25P	3 ~ 6	0.50
142.658.10.060	PSC50 x SKS10 - 60	90	60	35	30	27.6	M12 x 1.75P	3 ~ 10	0.60
142.658.13.060	PSC50 x SKS13 - 60	90	60	35	35	33	-	3 ~ 13	0.70
142.658.16.060	PSC50 x SKS16 - 60	90	60	38	40	40	-	3 ~ 16	0.80
143.658.06.090	PSC63 x SKS6 - 90	128	90	46	18	18	M8 x 1.25P	3 ~ 6	1.00
143.658.10.090	PSC63 x SKS10 - 90	128	90	60	30	30	M12 x 1.75P	3 ~ 10	1.10
143.658.13.090	PSC63 x SKS13 - 90	128	90	63	35	33	M12 x 1.75P	3 ~ 13	1.20
143.658.16.100	PSC63 x SKS16 - 100	138	100	71	40	40	M18 x 1.5P	3 ~ 16	1.30
143.658.20.100	PSC63 x SKS20 - 100	138	100	75	48.5	48.5	M22 x 1.5P	3 ~ 20	1.40

Product information:

► Balance: G2.5 25,000 rpm. Higher balancing grade and revolution can be done upon request but additional charge is needed.

Standard Accessory: • NUT

Collet	Nut	Coolant Supply unit	Preset Screw	Spanner
P.W-25~28	P.W-47~48	P.W-60	P.W-82	P.W-62~67



PSC / SBL SLIM-FIT COLLET CHUCK

PSC / SBL 後拉式立銑刀夾頭

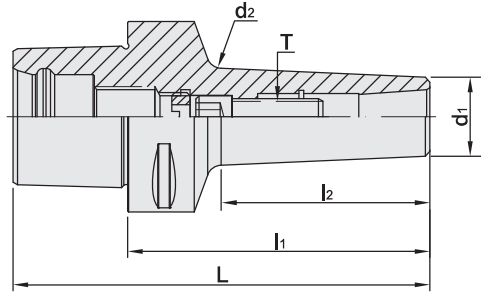

T W PAT NO. M274178

MODEL NO.	TYPE	L	l ₁	l ₂	d ₁	d ₂	T	TORQUE		SIZE RANGE	WEIGHT (KGS)
								N.m	lbf-ft		
140.648.06.075	PSC32 x SBL6 - 75	94	75	58	14	20.1	M6 x 1.0P	12	9	3 ~ 6	0.50
140.648.12.090	PSC32 x SBL12 - 90	109	90	74	26	31.2	M10 x 1.5P	45	33	3 ~ 12	0.70
141.648.06.075	PSC40 x SBL6 - 75	99	75	43	14	18.5	M6 x 1.0P	12	9	3 ~ 6	0.60
141.648.12.090	PSC40 x SBL12 - 90	114	90	68	26	31.9	M10 x 1.5P	45	33	3 ~ 12	0.70
141.648.20.105	PSC40 x SBL20 - 105	129	105	57	35	40	M12 x 1.75P	60	44	3 ~ 20	0.80
142.648.06.080	PSC50 x SBL6 - 80	110	80	45	14	18.8	M6 x 1.0P	12	9	3 ~ 6	0.60
142.648.08.100	PSC50 x SBL8 - 100	130	100	70.5	20	27.3	M8 x 1.25P	29	21	3 ~ 8	0.65
142.648.12.105	PSC50 x SBL12 - 105	135	105	80	26	33	M10 x 1.5P	45	33	3 ~ 12	0.70
142.648.20.115	PSC50 x SBL20 - 115	145	115	94	35	43.2	M12 x 1.75P	60	44	3 ~ 20	0.80
143.648.06.080	PSC63 x SBL6 - 80	118	80	43	14	18.5	M6 x 1.0P	12	9	3 ~ 6	1.00
143.648.08.100	PSC63 x SBL8 - 100	138	100	68.5	20	27.1	M8 x 1.25P	29	21	3 ~ 8	0.98
143.648.12.100	PSC63 x SBL12 - 100	138	100	69	26	32	M10 x 1.5P	45	33	3 ~ 12	1.20
143.648.20.120	PSC63 x SBL20 - 120	158	120	91	35	42.9	M12 x 1.75P	60	44	3 ~ 20	1.40
144.648.06.080	PSC80 x SBL6 - 80	128	80	40.5	14	18.2	M6 x 1.0P	12	9	3 ~ 6	2.10
144.648.08.100	PSC80 x SBL8 - 100	148	100	60.5	20	26.3	M8 x 1.25P	29	21	3 ~ 8	1.9
144.648.12.100	PSC80 x SBL12 - 100	148	100	31.2	26	60.4	M10 x 1.5P	45	33	3 ~ 12	2.40
144.648.20.120	PSC80 x SBL20 - 120	168	120	42	35	80.4	M12 x 1.75P	60	44	3 ~ 20	2.60

Product information:

► Balance: G2.5 25,000 rpm. Higher balancing grade and revolution can be done upon request but additional charge is needed.

Collet	Coolant Supply unit	Screw	Spanner
P.W-29	P.W-60	P.W-85	P.W-66

PSC / SBLC SLIM-FIT COLLET CHUCK

PSC / SBLC 後拉式立銑刀夾頭



T W PAT NO. M274178

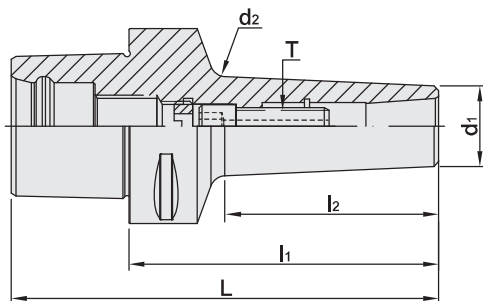

MODEL NO.	TYPE	L	l ₁	l ₂	d ₁	d ₂	T	TORQUE		SIZE RANGE	WEIGHT (KGS)
								N.m	lbf-ft		
140.648C.06.075	PSC32 x SBLC6 - 75	94	75	58	14	20.1	M6 x 1.0P	12	9	3 ~ 6	0.50
140.648C.12.090	PSC32 x SBLC12 - 90	109	90	74	26	31.2	M10 x 1.5P	45	33	3 ~ 12	0.70
141.648C.06.075	PSC40 x SBLC6 - 75	99	75	43	14	18.5	M6 x 1.0P	12	9	3 ~ 6	0.60
141.648C.12.090	PSC40 x SBLC12 - 90	114	90	68	26	31.9	M10 x 1.5P	45	33	3 ~ 12	0.70
141.648C.20.105	PSC40 x SBLC20 - 105	129	105	57	35	40	M12 x 1.75P	60	44	3 ~ 20	0.80
142.648C.06.080	PSC50 x SBLC6 - 80	110	80	45	14	18.8	M6 x 1.0P	12	9	3 ~ 6	0.60
142.648C.08.100	PSC50 x SBLC8 - 100	130	100	70.5	20	27.3	M8 x 1.25P	29	21	3 ~ 8	0.65
142.648C.12.105	PSC50 x SBLC12 - 105	135	105	80	26	33	M10 x 1.5P	45	33	3 ~ 12	0.70
142.648C.20.115	PSC50 x SBLC20 - 115	145	115	94	35	43.2	M12 x 1.75P	60	44	3 ~ 20	0.80
143.648C.06.080	PSC63 x SBLC6 - 80	118	80	43	14	18.5	M6 x 1.0P	12	9	3 ~ 6	1.00
143.648C.08.100	PSC63 x SBLC8 - 100	138	100	68.5	20	27.1	M8 x 1.25P	29	21	3 ~ 8	0.98
143.648C.12.100	PSC63 x SBLC12 - 100	138	100	69	26	32	M10 x 1.5P	45	33	3 ~ 12	1.20
143.648C.20.120	PSC63 x SBLC20 - 120	158	120	91	35	42.9	M12 x 1.75P	60	44	3 ~ 20	1.40
144.648C.06.080	PSC80 x SBLC6 - 80	128	80	40.5	14	18.2	M6 x 1.0P	12	9	3 ~ 6	2.10
144.648C.08.100	PSC80 x SBLC8 - 100	148	100	60.5	20	26.3	M8 x 1.25P	29	21	3 ~ 8	1.9
144.648C.12.100	PSC80 x SBLC12 - 100	148	100	31.2	26	60.4	M10 x 1.5P	45	33	3 ~ 12	2.40
144.648C.20.120	PSC80 x SBLC20 - 120	168	120	42	35	80.4	M12 x 1.75P	60	44	3 ~ 20	2.60

Product information:

- ▶ Balance: G2.5 25,000 rpm. Higher balancing grade and revolution can be done upon request but additional charge is needed.
- ▶ Used with SLC sealed collet and coolant through cutters.

Collet	Coolant Supply unit	Screw	Spanner
P.W-30	P.W-60	P.W-85	P.W-66



PSC / MLD MULTI-LOCK MILLING CHUCK

PSC / MLD 直式筒夾銑床夾頭



T W PAT NO. M447277
T W PAT NO. M430337
T W PAT NO. M451185
C N PAT NO. ZL201220749784.4
C H PAT NO. ZL201220749942.6

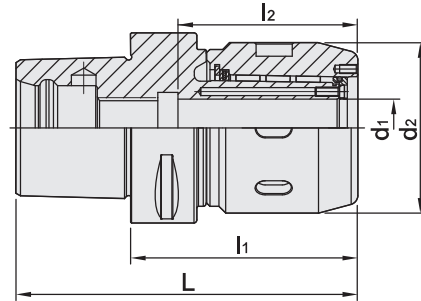

METRIC

MODEL NO.	TYPE	L	l ₁	l ₂	d ₁	d ₂	WEIGHT (KGS)
142.463G.16.065	PSC50 x MLD16 - 65	95	65	56.7	16	48	1.00
142.463G.16.090	PSC50 x MLD16 - 90	120	90	56.7	16	48	1.50
142.463G.20.075	PSC50 x MLD20 - 75	105	75	59.3	20	56.5	1.20
142.463G.20.090	PSC50 x MLD20 - 90	120	90	59.3	20	56.5	1.40
142.463G.25.085	PSC50 x MLD25 - 85	115	85	58.2	25	60	1.60
142.463G.25.105	PSC50 x MLD25 - 105	135	105	58.2	25	60	1.80
142.463G.32.090	PSC50 x MLD32 - 90	120	90	71.7	32	71	1.90
143.463G.16.070	PSC63 x MLD16 - 70	108	70	56.7	16	48	1.20
143.463G.16.090	PSC63 x MLD16 - 90	128	90	59.3	16	48	1.40
143.463G.20.075	PSC63 x MLD20 - 75	113	75	59.3	20	56.5	1.40
143.463G.20.090	PSC63 x MLD20 - 90	128	90	59.3	20	56.5	1.60
143.463G.25.080	PSC63 x MLD25 - 80	118	80	58.2	25	60	1.70
143.463G.25.090	PSC63 x MLD25 - 90	128	90	58.2	25	60	1.90
143.463G.32.085	PSC63 x MLD32 - 85	123	85	71.7	32	71	2.20
143.463G.32.105	PSC63 x MLD32 - 105	143	105	71.7	32	71	2.40
144.463G.16.070	PSC80 x MLD16 - 70	118	70	56.7	16	48	2.30
144.463G.16.105	PSC80 x MLD16 - 105	153	105	56.7	16	48	2.50
144.463G.20.080	PSC80 x MLD20 - 80	128	80	59.3	20	56.5	2.60
144.463G.20.105	PSC80 x MLD20 - 105	153	105	59.3	20	56.5	2.80
144.463G.25.085	PSC80 x MLD25 - 85	133	85	58.2	25	60	2.80
144.463G.25.105	PSC80 x MLD25 - 105	153	105	58.2	25	60	3.10
144.463G.32.090	PSC80 x MLD32 - 90	138	90	71.7	32	71	2.90
144.463G.32.105	PSC80 x MLD32 - 105	153	105	71.7	32	71	3.10

Features:

- ▶ Good clamping power. The clamping power of MLD32 type is around 1000 N-m.
- ▶ Runout accuracy of MLD holder body: within 0.005mm.
- ▶ Runout accuracy with collet: within 0.02mm.
- ▶ The tolerance requirement of tool shank diameter is h6.
- ▶ Internal bearing cage helps increase the clamping force.
- ▶ After fastening, the nuts and tool holders contact tight to enhance the cutting rigidity.
- ▶ Coolant options: through the center of holder or cutter. Use sealed caps and SR rings for coolant through cutter.

Product information:

- ▶ The pre-balance reaches G6.3 8,000 rpm. Higher balancing grade and revolution can be done upon request but additional charge is needed.
- ▶ AD+B type is available, please inform us when making an order.
- ▶ MAS/BT30 tool holders are without coolant supply over collars.

Standard Accessory: • NUT • SET SCREW

Collet	Sealed Cap	SR Sealed Ring	Coolant Supply unit	Set Screw	Spanner	Spanner
P.W-32~33	P.W-52	P.W-53	P.W-60	P.W-82	P.W-65~66	P.W-67

PSC / MLD MULTI-LOCK MILLING CHUCK

PSC / MLD 直式筒夾銑床夾頭



T W PAT NO. M447277
T W PAT NO. M430337
T W PAT NO. M451185
C N PAT NO. ZL201220749784.4
C H PAT NO. ZL201220749942.6

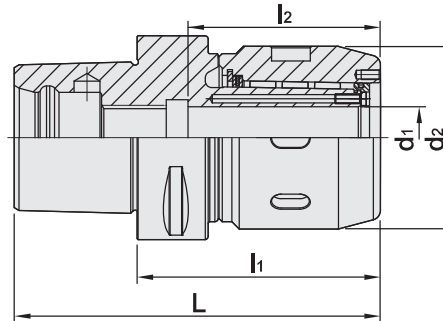

INCHES

MODEL NO.	TYPE	L	l ₁	l ₂	d ₁	d ₂	WEIGHT (KGS)
142.463G.61.250	PSC50 x MLD5/8" - 2.5"	3.681	2.5	2.23	0.625	1.889	1.00
142.463G.61.350	PSC50 x MLD5/8" - 3.5"	4.681	3.5	2.23	0.625	1.889	1.50
142.463G.64.300	PSC50 x MLD3/4" - 3"	4.181	3	2.34	0.75	2.224	1.20
142.463G.64.350	PSC50 x MLD3/4" - 3.5"	4.681	3.5	2.34	0.75	2.224	1.40
142.463G.68.335	PSC50 x MLD1" - 3.35"	4.531	3.35	2.49	1	2.362	1.60
142.463G.68.413	PSC50 x MLD1" - 4.13"	5.314	4.13	2.49	1	2.362	1.80
142.463G.72.350	PSC50 x MLD1-1/4" - 3.5"	4.681	3.5	2.8	1.25	2.795	1.90
143.463G.61.275	PSC63 x MLD5/8" - 2.75"	4.246	2.75	2.23	0.625	1.889	1.20
143.463G.61.350	PSC63 x MLD5/8" - 3.5"	4.996	3.5	2.23	0.625	1.889	1.40
143.463G.64.300	PSC63 x MLD3/4" - 3"	4.496	3	2.34	0.75	2.224	1.40
143.463G.64.350	PSC63 x MLD3/4" - 3.5"	4.996	3.5	2.34	0.75	2.224	1.60
143.463G.68.315	PSC63 x MLD1" - 3.15"	4.645	3.15	2.49	1	2.362	1.70
143.463G.68.350	PSC63 x MLD1" - 3.5"	4.996	3.5	2.49	1	2.362	1.90
143.463G.72.335	PSC63 x MLD1-1/4" - 3.35"	4.846	3.35	2.8	1.25	2.795	2.20
143.463G.72.413	PSC63 x MLD1-1/4" - 4.13"	5.626	4.13	2.8	1.25	2.795	2.40
144.463G.61.275	PSC80 x MLD5/8" - 2.75"	4.639	2.75	2.23	0.625	1.889	2.30
144.463G.61.413	PSC80 x MLD5/8" - 4.13"	6.019	4.13	2.23	0.625	1.889	2.50
144.463G.64.315	PSC80 x MLD3/4" - 3.15"	5.039	3.15	2.34	0.75	2.224	2.60
144.463G.64.413	PSC80 x MLD3/4" - 4.13"	6.019	4.13	2.34	0.75	2.224	2.80
144.463G.68.335	PSC80 x MLD1" - 3.35"	5.239	3.35	2.49	1	2.362	2.80
144.463G.68.413	PSC80 x MLD1" - 4.13"	6.019	4.13	2.49	1	2.362	3.10
144.463G.72.350	PSC80 x MLD1-1/4" - 3.5"	5.389	3.5	2.8	1.25	2.795	2.90
144.463G.72.413	PSC80 x MLD1-1/4" - 4.13"	6.019	4.13	2.8	1.25	2.795	3.10

Features:

- ▶ Good clamping power. The clamping power of MLD32 type is around 1000 N-m.
- ▶ Runout accuracy of MLD holder body: within 0.005mm.
- ▶ Runout accuracy with collet: within 0.02mm.
- ▶ The tolerance requirement of tool shank diameter is h6.
- ▶ Internal bearing cage helps increase the clamping force.
- ▶ After fastening, the nuts and tool holders contact tight to enhance the cutting rigidity.
- ▶ Coolant options: through the center of holder or cutter. Use sealed caps and SR rings for coolant through cutter.

Product information:

- ▶ The pre-balance reaches G6.3 8,000 rpm. Higher balancing grade and revolution can be done upon request but additional charge is needed.
- ▶ AD+B type is available, please inform us when making an order.
- ▶ MAS/BT30 tool holders are without coolant supply over collars.

Standard Accessory: • NUT • SET SCREW

Collet	Sealed Cap	SR Sealed Ring	Coolant Supply unit	Set Screw	Spanner	Spanner
P.W-32~33	P.W-52	P.W-53	P.W-60	P.W-82	P.W-65~66	P.W-67



PSC / SLN SIDE LOCK END MILL HOLDER

PSC / SLN 側固式立銑刀柄

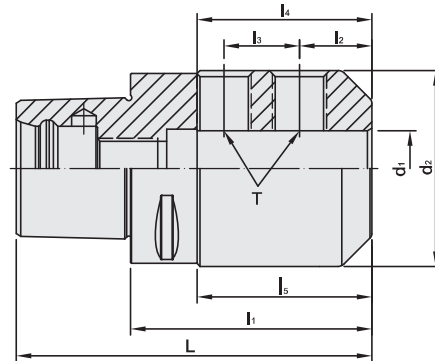

METRIC

MODEL NO.	TYPE	L	l ₁	l ₂	l ₃	l ₄	l ₅	d ₁	d ₂	T	WEIGHT (KGS)
140.653.06.045	PSC32 x SLN6 - 45	64	45	18	-	35	29	6	25	M6	0.30
140.653.08.045	PSC32 x SLN8 - 45	64	45	18	-	35	29.5	8	28	M8	0.30
140.653.10.050	PSC32 x SLN10 - 50	69	50	20	-	39	35	10	35	M10	0.40
140.653.12.055	PSC32 x SLN12 - 55	74	55	22.5	-	38	40	12	42	M12	0.30
141.653.06.050	PSC40 x SLN6 - 50	74	50	18	-	35	25	6	25	M6	0.40
141.653.08.050	PSC40 x SLN8 - 50	74	50	18	-	35	26	8	28	M8	0.40
141.653.10.050	PSC40 x SLN10 - 50	74	50	20	-	39	27.5	10	35	M10	0.50
141.653.12.055	PSC40 x SLN12 - 55	79	55	22.5	-	44	35	12	42	M12	0.60
141.653.14.055	PSC40 x SLN14 - 55	79	55	22.5	-	39	35	14	44	M12	0.60
141.653.16.055	PSC40 x SLN16 - 55	79	55	24	-	37	35	16	47	M14	0.70
142.653.06.050	PSC50 x SLN6 - 50	80	50	18	-	35	25	6	25	M6	0.60
142.653.08.050	PSC50 x SLN8 - 50	80	50	18	-	35	25	8	28	M8	0.70
142.653.10.055	PSC50 x SLN10 - 55	85	55	20	-	39	30	10	35	M10	0.70
142.653.12.060	PSC50 x SLN12 - 60	90	60	22.5	-	44	38	12	42	M12	0.90
142.653.14.060	PSC50 x SLN14 - 60	90	60	22.5	-	44	37	14	44	M12	0.80
142.653.16.060	PSC50 x SLN16 - 60	90	60	24	-	43	39	16	48	M14	1.00
142.653.18.060	PSC50 x SLN18 - 60	90	60	24	-	45	-	18	50	M14	1.00
142.653.20.060	PSC50 x SLN20 - 60	90	60	25	-	43	40	20	52	M16	1.00
142.653.25.080	PSC50 x SLN25 - 80	110	80	24	25	58	60	25	65	M18	1.80

Product information:

- ▶ Internal hole tolerance: H5 (DIN-1835-B standard).
- ▶ The tolerance requirement of tool shank diameter is h6.
- ▶ The pre-balance reaches G6.3 10,000 rpm. Higher balancing grade and revolution can be done upon request but additional charge is needed.

Coolant Supply unit Lock Screw



P.W-60



P.W-84

PSC / SLN SIDE LOCK END MILL HOLDER

PSC / SLN 側固式立銑刀柄



台灣精品 2012
TAIWAN EXCELLENCE

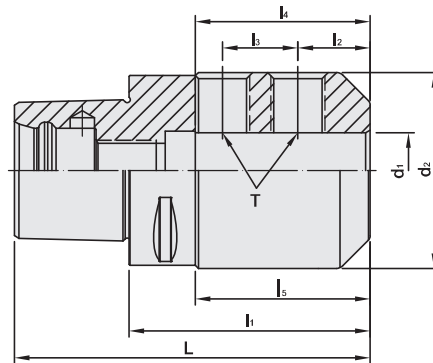

METRIC

MODEL NO.	TYPE	L	l ₁	l ₂	l ₃	l ₄	l ₅	d ₁	d ₂	T	WEIGHT (KGS)
143.653.06.055	PSC63 x SLN6 - 55	93	55	18	-	35	28	6	25	M6	0.90
143.653.08.055	PSC63 x SLN8 - 55	93	55	18	-	39	28	8	28	M8	0.90
143.653.10.060	PSC63 x SLN10 - 60	98	60	20	-	39	33	10	35	M10	1.00
143.653.12.060	PSC63 x SLN12 - 60	98	60	22.5	-	44	33	12	42	M12	1.10
143.653.14.060	PSC63 x SLN14 - 60	98	60	22.5	-	44	33	14	44	M12	1.10
143.653.16.065	PSC63 x SLN16 - 65	103	65	24	-	47	40	16	48	M14	1.20
143.653.18.065	PSC63 x SLN18 - 65	103	65	24	-	44	40	18	50	M14	1.20
143.653.20.065	PSC63 x SLN20 - 65	103	65	25	-	49	40	20	52	M16	1.50
143.653.25.080	PSC63 x SLN25 - 80	118	80	24	25	58	58	25	65	M18	1.90
143.653.32.090	PSC63 x SLN32 - 90	128	90	24	28	58	63	32	72	M20	2.40
143.653.40.100	PSC63 x SLN40 - 100	138	100	30	32	75	78	40	90	M20	3.70
144.653.06.070	PSC80 x SLN6 - 70	118	70	18	-	35	35	6	25	M6	2.10
144.653.08.070	PSC80 x SLN8 - 70	118	70	18	-	35	35	8	28	M8	2.10
144.653.10.070	PSC80 x SLN10 - 70	118	70	20	-	39	35	10	35	M10	2.20
144.653.12.070	PSC80 x SLN12 - 70	118	70	22.5	-	44	35	12	42	M12	2.20
144.653.14.070	PSC80 x SLN14 - 70	118	70	22.5	-	44	35	14	44	M12	2.30
144.653.16.070	PSC80 x SLN16 - 70	118	70	24	-	47	35	16	48	M14	2.30
144.653.18.070	PSC80 x SLN18 - 70	118	70	24	-	44	35	18	50	M14	2.30
144.653.20.070	PSC80 x SLN20 - 70	118	70	25	-	49	37	20	52	M16	2.30
144.653.25.090	PSC80 x SLN25 - 90	138	90	24	25	58	59	25	65	M18	2.40
144.653.32.095	PSC80 x SLN32 - 95	143	95	24	28	63	63.5	32	72	M20	2.90
144.653.40.110	PSC80 x SLN40 - 110	158	110	30	32	75	79.5	40	90	M20	4.50
144.653.50.120	PSC80 x SLN50 - 120	168	120	35	35	78	90	50	98	M24	5.50

Product information:

- ▶ Internal hole tolerance: H5 (DIN-1835-B standard).
- ▶ The tolerance requirement of tool shank diameter is h6.
- ▶ The pre-balance reaches G6.3 10,000 rpm. Higher balancing grade and revolution can be done upon request but additional charge is needed.

Coolant Supply unit Lock Screw



P.W-60



P.W-84



PSC / SLN SIDE LOCK END MILL HOLDER

PSC / SLN 側固式立銑刀柄

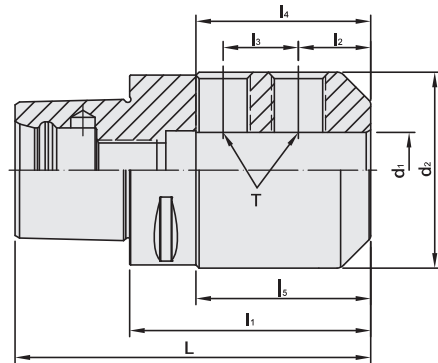

INCHES

MODEL NO.	TYPE	L	l ₁	l ₂	l ₃	l ₄	l ₅	d ₁	d ₂	T	WEIGHT (KGS)
140.653.54.177	PSC32 x SLN1/4" - 1.77"	2.52	1.77	0.63	-	1.38	0.984	0.25	0.78	1/4 - 28	0.30
140.653.55.177	PSC32 x SLN5/16" - 1.77"	2.52	1.77	0.63	-	1.38	1.06	0.3125	0.88	5/16 - 24	0.30
140.653.56.197	PSC32 x SLN3/8" - 1.97"	2.72	1.97	0.75	-	1.38	1.34	0.375	1	3/8 - 24	0.40
140.653.58.217	PSC32 x SLN1/2" - 2.17"	2.91	2.17	0.875	-	1.732	1.57	0.5	1.25	7/6 - 20	0.30
141.653.54.197	PSC40 x SLN1/4" - 1.97"	2.91	1.97	0.63	-	1.38	0.984	0.25	0.78	1/4 - 28	0.40
141.653.55.197	PSC40 x SLN5/16" - 1.97"	2.91	1.97	0.6	-	1.38	1.06	0.3125	0.88	5/16 - 24	0.40
141.653.56.197	PSC40 x SLN3/8" - 1.97"	2.91	1.97	0.75	-	1.38	1.08	0.375	1	3/8 - 24	0.50
141.653.58.217	PSC40 x SLN1/2" - 2.17"	3.11	2.17	0.875	-	1.732	1.34	0.5	1.25	7/6 - 20	0.60
141.653.59.217	PSC40 x SLN9/16" - 2.17"	3.11	2.17	0.937	-	1.81	1.38	0.5625	1.75	1/2 - 20	0.60
141.653.61.217	PSC40 x SLN5/8" - 2.17"	3.11	2.17	0.937	-	1.73	1.34	0.625	1.5	1/2 - 20	0.70
142.653.54.200	PSC50 x SLN1/4" - 2"	3.18	2	0.63	-	1.38	1	0.25	0.78	1/4 - 28	0.60
142.653.55.200	PSC50 x SLN5/16" - 2"	3.18	2	0.6	-	1.38	1.02	0.3125	0.88	5/16 - 24	0.70
142.653.56.217	PSC50 x SLN3/8" - 2.17"	3.35	2.17	0.75	-	1.38	1.18	0.375	1	3/8 - 24	0.70
142.653.58.236	PSC50 x SLN1/2" - 2.36"	3.54	2.36	0.875	-	1.732	1.38	0.5	1.25	7/6 - 20	0.90
142.653.59.236	PSC50 x SLN9/16" - 2.36"	3.54	2.36	0.937	-	1.77	1.46	0.5625	1.75	1/2 - 20	0.80
142.653.61.236	PSC50 x SLN5/8" - 2.36"	3.54	2.36	0.937	-	1.69	1.46	0.625	1.5	1/2 - 20	1.00
142.653.64.236	PSC50 x SLN3/4" - 2.36"	3.54	2.36	1	-	1.69	1.53	0.75	1.75	5/8 - 18	1.00
142.653.68.315	PSC50 x SLN1" - 3.15"	4.33	3.15	1.125	1	2.559	2.36	1	2	3/4 - 16	1.00
143.653.54.217	PSC63 x SLN1/4" - 2.17"	3.66	2.17	0.63	-	1.38	1.102	0.25	0.78	1/4 - 28	1.80
143.653.55.217	PSC63 x SLN5/16" - 2.17"	3.66	2.17	0.6	-	1.38	1.102	0.3125	0.88	5/16 - 24	0.90
143.653.56.236	PSC63 x SLN3/8" - 2.36"	3.86	2.36	0.75	-	1.38	1.299	0.375	1	3/8 - 24	0.90
143.653.58.236	PSC63 x SLN1/2" - 2.36"	3.86	2.36	0.875	-	1.732	1.299	0.5	1.25	7/6 - 20	1.00
143.653.59.236	PSC63 x SLN9/16" - 2.36"	3.86	2.36	0.937	-	1.85	1.338	0.5625	1.75	1/2 - 20	1.10
143.653.61.256	PSC63 x SLN5/8" - 2.56"	4.06	2.56	0.937	-	1.85	1.496	0.625	1.5	1/2 - 20	1.10
143.653.64.256	PSC63 x SLN3/4" - 2.56"	4.06	2.56	1	-	1.929	1.496	0.75	1.75	5/8 - 18	1.20
143.653.68.315	PSC63 x SLN1" - 3.15"	4.65	3.15	1.125	-	2.559	2.283	1	2	3/4 - 16	1.20
143.653.72.354	PSC63 x SLN1-1/4" - 3.54"	5.04	3.54	1.125	1	2.559	2.677	1.25	2.5	3/4 - 16	1.50
143.653.77.394	PSC63 x SLN1-1/2" - 3.94"	5.43	3.94	1.125	1	2.56	3.07	1.5	2.5	3/4 - 16	1.90

Product information:

- ▶ Internal hole tolerance: H5(DIN-1835-B standard).
- ▶ The tolerance requirement of tool shank diameter is h6.
- ▶ The pre-balance reaches G6.3 10,000 rpm. Higher balancing grade and revolution can be done upon request but additional charge is needed.

Coolant Supply unit Lock Screw



P.W-60



P.W-84

PSC FACE MILL ARBOR

FMA TYPE

PSC / FMA 平面銑刀柄



台灣精品 2012
TAIWAN EXCELLENCE

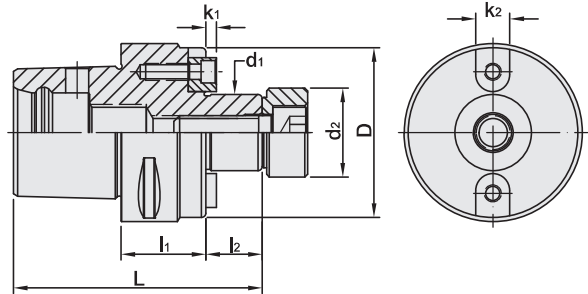

INCHES

MODEL NO.	TYPE	L	l ₁	l ₂	d ₁	d ₂	D	k ₁	k ₂	WEIGHT (KGS)
142.151.64.150	PSC50 x FMA3/4" - 1.5"	3.49	1.5	0.69	0.75	0.875	1.69	0.19	0.31	0.50
142.151.68.157	PSC50 x FMA1" - 1.57"	3.44	1.57	0.69	1	1.187	2.19	0.19	0.375	0.80
143.151.68.200	PSC63 x FMA1" - 2"	4.18	2	0.69	1	1.187	2.19	0.19	0.375	0.90
143.151.72.200	PSC63 x FMA1-1/4" - 2"	4.18	2	0.69	1.25	1.5	2.75	0.25	0.5	1.00
143.151.77.200	PSC63 x FMA1-1/2" - 2"	4.48	2	0.99	1.5	1.75	2.95	0.35	0.63	1.60
144.151.64.118	PSC80 x FMA3/4" - 1.18"	3.76	1.18	0.69	0.75	0.875	3.15	0.19	0.31	1.70
144.151.68.118	PSC80 x FMA1" - 1.18"	3.76	1.18	0.69	1	1.187	3.15	0.19	0.375	1.80
144.151.72.118	PSC80 x FMA1-1/4" - 1.18"	3.76	1.18	0.69	1.25	1.5	3.15	0.25	0.5	2.00
144.151.77.236	PSC80 x FMA1-1/2" - 2.36"	5.23	2.36	0.99	1.5	1.75	2.95	0.32	0.63	2.10

Features:

- ▶ d1 tolerance: h6.

Coolant Supply unit	Screw
 P.W-60	 P.W-84



PSC FACE MILL ARBOR

FMB TYPE

PSC / FMB 平面銑刀柄

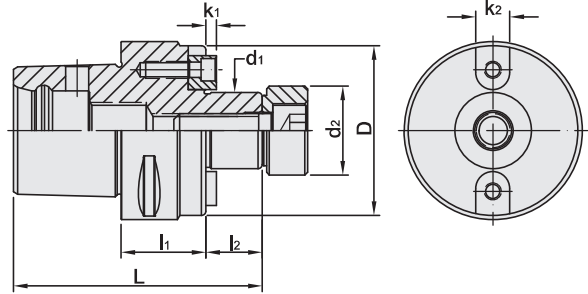

 台灣精品 2012
 TAIWAN EXCELLENCE

METRIC

MODEL NO.	TYPE	L	l ₁	l ₂	D	d ₁	d ₂	k ₁	k ₂	WEIGHT (KGS)
140.153.16.030	PSC32 x FMB16 - 30	65	30	16	32	16	-	4	8	0.30
141.153.16.032	PSC40 x FMB16 - 32	72	32	16	34	16	-	4	8	0.30
141.153.16.055	PSC40 x FMB16 - 55	95	55	16	34	16	-	4	8	0.40
141.153.22.025	PSC40 x FMB22 - 25	68	25	19	40	22	26	4.8	10	0.40
141.153.22.055	PSC40 x FMB22 - 55	98	55	19	48	22	26	4.8	10	0.70
142.153.16.035	PSC50 x FMB16 - 35	81	35	16	34	16	-	4	8	0.60
142.153.16.070	PSC50 x FMB16 - 70	116	70	16	34	16	-	4	8	0.70
142.153.22.025	PSC50 x FMB22 - 25	74	25	19	48	22	26	4.8	10	0.60
142.153.22.070	PSC50 x FMB22 - 70	119	70	19	48	22	26	4.8	10	1.00
142.153.27.025	PSC50 x FMB27 - 25	75	25	20	50	27	31.5	5.8	12	0.70
142.153.32.040	PSC50 x FMB32 - 40	92	40	22	63	32	41	6.8	14	1.20
143.153.16.040	PSC63 x FMB16 - 40	94	40	16	34	16	-	4	8	0.90
143.153.22.040	PSC63 x FMB22 - 40	97	40	19	48	22	26	4.8	10	0.90
143.153.27.030	PSC63 x FMB27 - 30	88	30	20	60	27	31.5	5.8	12	1.00
143.153.32.045	PSC63 x FMB32 - 45	105	45	22	78	32	41	6.8	14	1.60
143.153.40.045	PSC63 x FMB40 - 45	108	45	25	80	40	48	8.3	16	1.60
144.153.16.050	PSC80 x FMB16 - 50	114	50	16	34	16	-	4	8	1.80
144.153.22.030	PSC80 x FMB22 - 30	97	30	19	48	22	26	4.8	10	1.80
144.153.27.030	PSC80 x FMB27 - 30	98	30	20	60	27	31.5	5.8	12	2.00
144.153.32.030	PSC80 x FMB32 - 30	100	30	22	78	32	41	6.8	14	2.10
144.153.40.030	PSC80 x FMB40 - 30	103	30	25	80	40	48	8.3	16	2.10
144.153.60.060	PSC80 x FMB60 - 60	148	60	40	129	60	-	12.5	25.4	5.30
145.153.40.040	PSC80X x FMB40 - 40	113	40	25	80	40	48	8.3	16	3.20
145.153.60.070	PSC80X x FMB60 - 70	158	70	40	129	60	-	12.5	25.4	6.90

Features:

- ▶ d₁ tolerance: h6.

Coolant Supply unit	Screw
	
P.W-60	P.W-84

PSC FACE MILL ARBOR

FMC TYPE

PSC / FMC 平面銑刀柄



台灣精品 2012
TAIWAN EXCELLENCE

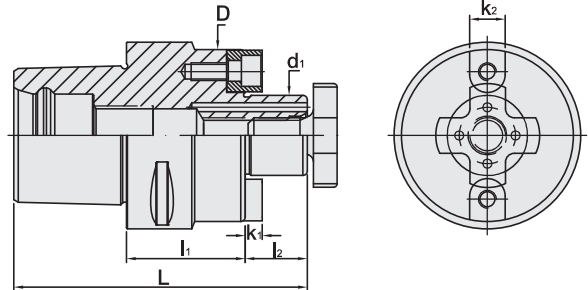

MODEL NO.	TYPE	L	l ₁	l ₂	D	d ₁	k ₁	k ₂	WEIGHT (KGS)
140.157.16.030	PSC32 x FMC16 - 30	66	30	17	38	16	5	8	0.30
141.157.16.035	PSC40 x FMC16 - 35	79	35	17	38	16	5	8	0.30
141.157.22.040	PSC40 x FMC22 - 40	83	40	19	48	22	4.8	10	0.60
142.157.16.035	PSC50 x FMC16 - 35	82	35	17	38	16	5	8	0.70
142.157.22.040	PSC50 x FMC22 - 40	89	40	19	48	22	4.8	10	0.60
142.157.27.040	PSC50 x FMC27 - 40	91	40	21	58	27	5.8	12	0.70
142.157.32.040	PSC50 x FMC32 - 40	94	40	24	78	32	6.8	14	1.20
143.157.16.035	PSC63 x FMC16 - 35	90	35	17	38	16	5	8	0.90
143.157.22.040	PSC63 x FMC22 - 40	92	40	19	48	22	4.8	10	0.90
143.157.27.040	PSC63 x FMC27 - 40	99	40	21	58	27	5.8	12	0.90
143.157.32.040	PSC63 x FMC32 - 40	102	40	24	78	32	6.8	14	1.00
143.157.40.045	PSC63 x FMC40 - 45	110	45	27	89	40	8.3	16	1.60
144.157.27.050	PSC80 x FMC27 - 50	119	50	21	58	27	5.8	12	1.80
144.157.32.050	PSC80 x FMC32 - 50	122	50	24	78	32	6.8	14	2.00
144.157.40.055	PSC80 x FMC40 - 55	130	55	27	89	40	8.3	16	2.10



Features:

- ▶ With four coolant holes at the end of holder.

Nut	Coolant Supply unit	Spanner
P.W-61	P.W-60	P.W-61



PSC / SCA SIDE CUTTER ADAPTER

PSC / SCA 側銑刀柄



台灣精品 2012
TAIWAN EXCELLENCE

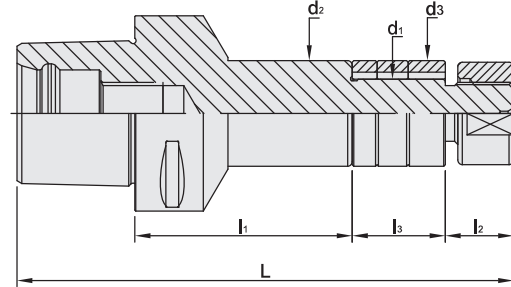

MODEL NO.	TYPE	L	l ₁	l ₂	l ₃	d ₁	d ₂	d ₃	WEIGHT (KGS)
140.649.16.020	PSC32 x SCA16 - 20	85	20	16	30	16	26	26	0.20
141.649.16.025	PSC40 x SCA16 - 25	95	25	16	30	16	26	26	0.30
141.649.22.025	PSC40 x SCA22 - 25	101	25	22	30	22	34	34	0.40
141.649.27.025	PSC40 x SCA27 - 25	107	25	28	30	27	41	40	0.60
142.649.16.025	PSC50 x SCA16 - 25	101	25	16	30	16	26	26	0.60
142.649.22.025	PSC50 x SCA22 - 25	107	25	22	30	22	34	34	0.70
142.649.27.025	PSC50 x SCA27 - 25	113	25	28	30	27	41	40	0.80
142.649.32.025	PSC50 x SCA32 - 25	117	25	32	30	32	47	46	0.90
143.649.16.060	PSC63 x SCA16 - 60	144	60	16	30	16	26	26	0.90
143.649.22.070	PSC63 x SCA22 - 70	160	70	22	30	22	34	34	1.00
143.649.27.090	PSC63 x SCA27 - 90	186	90	28	30	27	41	40	1.20
143.649.32.085	PSC63 x SCA32 - 85	185	85	32	30	32	47	46	1.40
144.649.16.040	PSC80 x SCA16 - 40	134	40	16	30	16	26	26	1.80
144.649.22.040	PSC80 x SCA22 - 40	140	40	22	30	22	34	34	2.00
144.649.27.030	PSC80 x SCA27 - 30	136	30	28	30	27	41	40	2.10
144.649.32.030	PSC80 x SCA32 - 30	140	30	32	30	32	47	46	2.20
144.649.40.030	PSC80 x SCA40 - 30	148	30	40	30	40	55	55	2.50

PSC EXTENSION ADAPTER FOR SAME DIAMETER

PSC 等徑套筒



台灣精品 2012
TAIWAN EXCELLENCE

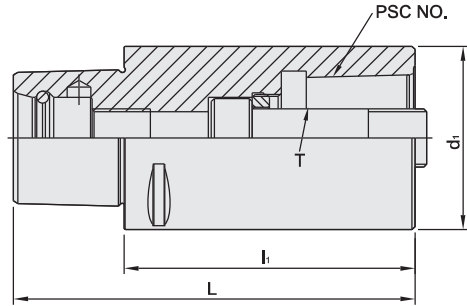

MODEL NO.	TYPE	PSC NO.	L	li	di	T	TORQUE		WEIGHT (KGS)
							MIN.	MAX.	
140.501.32.060	PSC32 x PSC32 - 60	PSC32	79	60	32	M12 x 1.5P	45Nm	55Nm	0.40
140.501.32.080	PSC32 x PSC32 - 80	PSC32	99	80	32	M12 x 1.5P	45Nm	55Nm	0.50
141.501.40.060	PSC40 x PSC40 - 60	PSC40	84	60	40	M14 x 1.5P	45Nm	55Nm	0.50
141.501.40.080	PSC40 x PSC40 - 80	PSC40	104	80	40	M14 x 1.5P	45Nm	55Nm	0.70
142.501.50.080	PSC50 x PSC50 - 80	PSC50	110	80	50	M16 x 1.5P	45Nm	55Nm	1.10
142.501.50.100	PSC50 x PSC50 - 100	PSC50	130	100	50	M16 x 1.5P	45Nm	55Nm	1.40
143.501.63.080	PSC63 x PSC63 - 80	PSC63	118	80	63	M20 x 2.0P	65Nm	75Nm	2.00
143.501.63.100	PSC63 x PSC63 - 100	PSC63	138	100	63	M20 x 2.0P	65Nm	75Nm	2.20
144.501.80.065	PSC80 x PSC80 - 65	PSC80	113	65	80	M20 x 2.0P	65Nm	75Nm	3.10
144.501.80.100	PSC80 x PSC80 - 100	PSC80	148	100	80	M20 x 2.0P	65Nm	75Nm	3.60
144.501.80.125	PSC80 x PSC80 - 125	PSC80	173	125	80	M20 x 2.0P	65Nm	75Nm	4.60
145.501.80.065	PSC80X x PSC80 - 65	PSC80	113	65	80	M20 x 2.0P	65Nm	75Nm	4.00
145.501.80.100	PSC80X x PSC80 - 100	PSC80	148	100	80	M20 x 2.0P	65Nm	75Nm	4.40
145.501.80.150	PSC80X x PSC80 - 150	PSC80	198	150	80	M20 x 2.0P	65Nm	75Nm	7.30
145.501.80X.100	PSC80X x PSC80X - 100	PSC80X	148	100	100	M20 x 2.0P	65Nm	75Nm	5.80

PSC EXTENSION ADAPTER

FOR DIFFERENT DIAMETER

PSC 異徑套筒



台灣精品 2012
TAIWAN EXCELLENCE

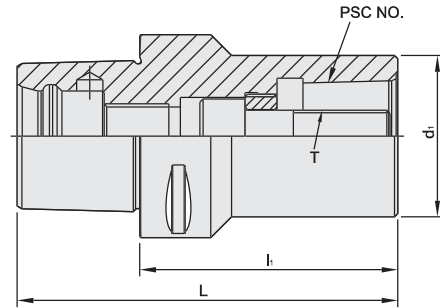

MODEL NO.	TYPE	NO.	L	l ₁	d ₁	T	TORQUE		WEIGHT (KGS)
							MIN.	MAX.	
141.501.32.055	PSC40 x PSC32 - 55	PSC32	79	55	32	M12 x 1.5P	45 Nm	55 Nm	0.50
141.501.32.070	PSC40 x PSC32 - 70	PSC32	94	70	32	M12 x 1.5P	45 Nm	55 Nm	0.60
142.501.32.060	PSC50 x PSC32 - 60	PSC32	90	60	32	M12 x 1.5P	45 Nm	55 Nm	0.60
142.501.40.065	PSC50 x PSC40 - 65	PSC40	95	65	40	M14 x 1.5P	45 Nm	55 Nm	0.80
142.501.40.085	PSC50 x PSC40 - 85	PSC40	115	85	40	M14 x 1.5P	45 Nm	55 Nm	1.10
143.501.32.070	PSC63 x PSC32 - 70	PSC32	108	70	32	M12 x 1.5P	45 Nm	55 Nm	1.10
143.501.40.080	PSC63 x PSC40 - 80	PSC40	118	80	40	M14 x 1.5P	45 Nm	55 Nm	1.20
143.501.50.080	PSC63 x PSC50 - 80	PSC50	118	80	50	M16 x 1.5P	45 Nm	55 Nm	1.50
143.501.50.110	PSC63 x PSC50 - 110	PSC50	148	110	50	M16 x 1.5P	45 Nm	55 Nm	2.20
144.501.32.060	PSC80 x PSC32 - 60	PSC32	108	60	32	M12 x 1.5P	45 Nm	55 Nm	1.70
144.501.40.070	PSC80 x PSC40 - 70	PSC40	118	70	40	M14 x 1.5P	45 Nm	55 Nm	1.90
144.501.50.045	PSC80 x PSC50 - 45	PSC50	93	45	50	M16 x 1.5P	45 Nm	55 Nm	1.50
144.501.50.080	PSC80 x PSC50 - 80	PSC50	128	80	50	M16 x 1.5P	45 Nm	55 Nm	2.20
144.501.63.055	PSC80 x PSC63 - 55	PSC63	103	55	63	M20 x 2.0P	65 Nm	75 Nm	2.30
144.501.63.080	PSC80 x PSC63 - 80	PSC63	128	80	63	M20 x 2.0P	65 Nm	75 Nm	2.50
144.501.63.120	PSC80 x PSC63 - 120	PSC63	168	120	63	M20 x 2.0P	65 Nm	75 Nm	4.00
145.501.63.055	PSC80X x PSC63 - 55	PSC63	103	55	63	M20 x 2.0P	65 Nm	75 Nm	3.00
145.501.63.080	PSC80X x PSC63 - 80	PSC63	128	80	63	M20 x 2.0P	65 Nm	75 Nm	3.40

PSC BLANK

PSC 素材

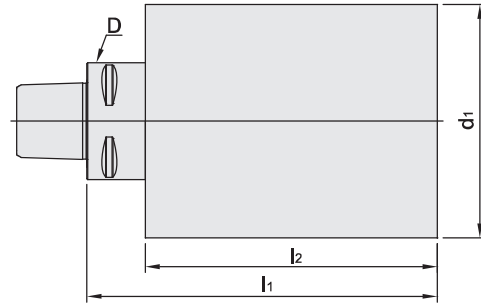

MODEL NO.	TYPE	D	d ₁	l ₁	l ₂	WEIGHT (KGS)
140.001.32.090	PSC32 x ϕ 32 - 90	32	32	90	-	0.53
140.001.60.060	PSC32 x ϕ 60 - 90	32	60	90	75	1.65
141.001.40.120	PSC40 x ϕ 40 - 120	40	40	120	-	1.30
141.001.80.120	PSC40 x ϕ 80 - 120	40	80	120	100	4.12
142.001.50.150	PSC50 x ϕ 50 - 150	50	50	150	-	2.38
142.001.95.150	PSC50 x ϕ 95 - 150	50	95	150	130	7.60
143.001.63.180	PSC63 x ϕ 63 - 180	63	63	180	-	4.56
143.001.120.180	PSC63 x ϕ 120 - 180	63	120	180	158	14.5
144.001.80.200	PSC80 x ϕ 80 - 200	80	80	200	-	8.30
144.001.145.200	PSC80 x ϕ 145 - 200	80	145	200	170	23.3
145.001.145.200	PSC80X x ϕ 145 - 200	100	145	200	168	23.2