

NT.MT CATEGORY

ER COLLET CHUCK SYSTEM	K-3
MLD MULTI - LOCK MILLING CHUCK	K-4
EOC COLLET CHUCK	K-5
TG COLLET CHUCK	K-6
SLN SIDE LOCK END MILL HOLDER	K-7
FACE MILL ARBOR	K-8
COMBI SHELL END MILL ARBOR	K-9
SPU DRILL CHUCK	K-10
DRILL CHUCK ARBOR	K-11
MORSE TAPER ADAPTER	K-12
ADAPTER	K-13

REFERENCE DETAILS

DIN 2080

- ▶ Shank body standard: **DIN 2080**
- ▶ Taper tolerance < **AT3**
- ▶ Hardness > **HRC 56°**
- ▶ Surface roughness: Ra < **0.25 μm**
- ▶ Roundness < **0.8 μm**
- ▶ Carbon depth > **0.8mm**
- ▶ The shank has pre-balance at G6.3, and can provide precision balance at G2.5. It can be ordered by request.

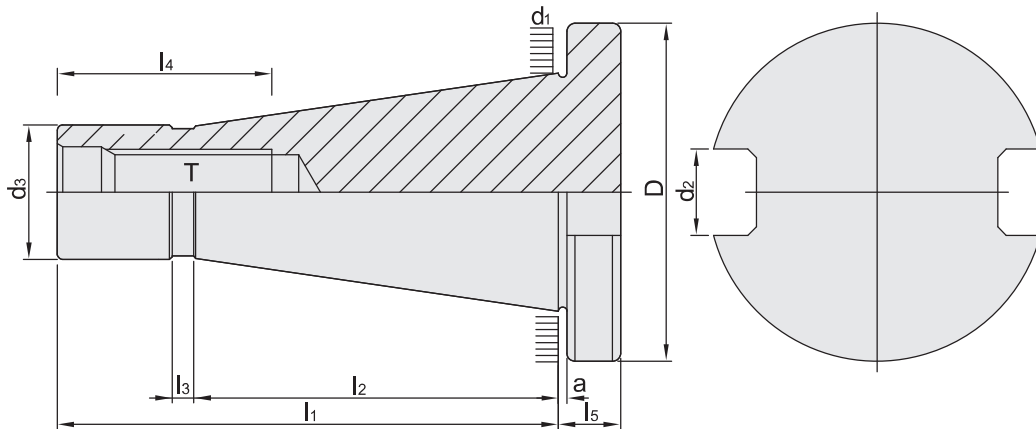

NT	D 0 -0.4	d ₁	d ₂ H12	d ₃ min	a ±0.2	l ₁	l ₂
30	50	31.75	16.1	17.04	1.6	68.4	48.4
40	63	44.45	16.1	24.92	1.6	93.4	65.4
50	97.5	69.85	25.7	39.19	3.2	126.8	101.8
NT	l ₃	l ₄	l ₅ ±0.15	T			
30	3	24	8	1/2" - 12W, M12 x 1.75P, 1/2" - 13UNC			
40	5	32	10	5/8" - 11W, M16 x 2.0P			
50	8	47	12	1" - 8W, M24 x 3.0P			

NT / ER COLLET HOLDER



NT / ER 銑夾頭柄

(DIN ISO 15488)



T W PAT NO. M298033
 T W PAT NO. M311791
 J P PAT NO. 3128766
 K R PAT NO. 20-0433603
 C N PAT NO. ZL200620132661.0
 C H PAT NO. 696550
 T R PAT NO. TR 2007 02942 Y
 I T PAT NO. N.0000266731

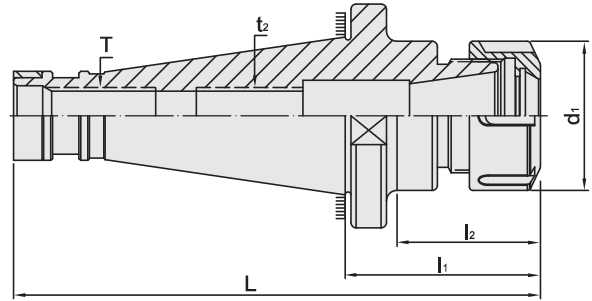

MODEL NO.	TYPE	L	l ₁	l ₂	d ₁	t ₂	T DRAW BAR		WEIGHT (KGS)
04732	NT30 x ER16A - 45	113.4	45	29.4	28	M10 x 1.5P	M12 x 1.75P	1/2" - 12	0.50
04733	NT30 x ER20A - 45	113.4	45	32	34	M12 x 1.75P	M12 x 1.75P	1/2" - 12	0.60
04734	NT30 x ER25 - 55	123.4	55	42	42	M16 x 2.0P	M12 x 1.75P	1/2" - 12	0.65
04735	NT30 x ER32 - 60	128.4	60	48	50	M16 x 2.0P	M12 x 1.75P	1/2" - 12	0.80
04736	NT30 x ER40 - 75	143.4	75	63	63	M16 x 2.0P	M12 x 1.75P	1/2" - 12	0.90
04738	NT40 x ER16A - 45	138.4	45	30	28	M10 x 1.5P	M16 x 2.0P	5/8" - 11	0.95
04740	NT40 x ER20A - 45	138.4	45	30	34	M12 x 1.75P	M16 x 2.0P	5/8" - 11	1.20
04742	NT40 x ER25 - 55	148.4	55	40	42	M16 x 2.0P	M16 x 2.0P	5/8" - 11	1.25
04743	NT40 x ER32 - 60	153.4	60	45	50	M16 x 2.0P	M16 x 2.0P	5/8" - 11	1.30
04745	NT40 x ER40 - 70	161.8	70	53.8	63	M20 x 2.0P	M16 x 2.0P	5/8" - 11	1.35
04746	NT40 x ER50 - 80	173.4	80	68	78	M24 x 2.0P	M16 x 2.0P	5/8" - 11	2.00
04748	NT50 x ER32 - 75	201.8	75	49	50	M16 x 2.0P	M24 x 3.0P	1" - 8	3.20
04749	NT50 x ER40 - 80	206.8	80	59	63	M20 x 2.0P	M24 x 3.0P	1" - 8	3.40
04750	NT50 x ER50 - 80	206.8	80	62	78	M24 x 2.0P	M24 x 3.0P	1" - 8	3.70

Fig.1

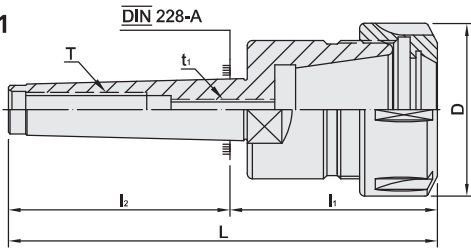
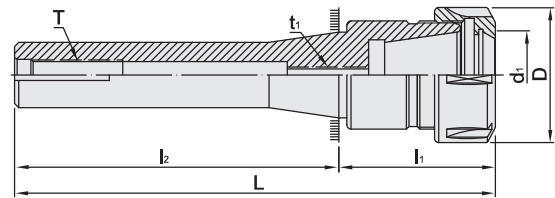

Fig.2



MODEL NO.	TYPE MTB x ER x l ₁	l ₂	L	D	t ₁	T DRAW BAR		Fig.	WEIGHT (KGS)
04700	MTB2 x ER20A - 52	64	116	35	M10 x 1.5P	M10 x 1.5P	3/8" W16	1	0.45
04701	MTB2 x ER25 - 55	64	119	42	M10 x 1.5P	M10 x 1.5P	3/8" W16	1	0.50
04702	MTB3 x ER25 - 55	81	136	42	M12 x 1.75P	M12 x 1.75P	1/2" W12	1	0.60
04703	MTB3 x ER32 - 60	81	141	50	M12 x 1.75P	M12 x 1.75P	1/2" W12	1	0.80
04704	MTB3 x ER40 - 70	81	151	63	M12 x 1.75P	M12 x 1.75P	1/2" W12	1	1.30
04705	MTB4 x ER32 - 60	102.5	162.5	50	M16 x 2.0P	M16 x 2.0P	5/8" W11	1	0.95
04706	MTB4 x ER40 - 70	102.5	172.5	63	M16 x 2.0P	M16 x 2.0P	5/8" W11	1	1.50
04717	R8 x ER16A - 38	101	136	28	16	M10 x 1.5P	7/16" NF20	2	0.65
04718	R8 x ER32 - 60	101	161	50	32	M12 x 1.75P	7/16" NF20	2	0.90
04719	R8 x ER40 - 65	101	168	63	40	M16 x 2.0P	7/16" NF20	2	1.15

Standard Accessory: • NUT

Collet	Nut	Preset Screw	Spanner
P.W-6~24	P.W-42	P.W-82	P.W-62~65



MLD MULTI-LOCK MILLING CHUCK

MLD 直式筒夾 銑床夾頭



台灣精品 2007
TAIWAN EXCELLENCE



T W PAT NO. M447277
T W PAT NO. M430337
T W PAT NO. M451185
C N PAT NO. ZL201220749784.4
C H PAT NO. ZL201220749942.6

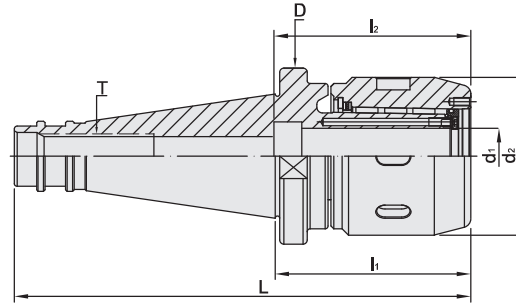

MODEL NO.	TYPE	L	l ₁	l ₂	D	d ₁	d ₂	T		WEIGHT (KGS)
85930G	NT30 x MLD20 - 70	138.4	70	63.5	50	20	56.5	1/2" - 12	M12 x 1.75P	1.90
85932G	NT40 x MLD20 - 70	163.4	70	63.5	52	20	56.5	5/8" - 11	M16 x 2.0P	2.30
85934G	R8 x MLD20 - 70	174	70	63.5	52	20	56.5	7/16" - 20		1.90
85938G	MTB5 x MLD32 - 90	218.5	90	71.8	67	32	71	1" - 8	M24 x 3.0P	3.80
85940G	NT40 x MLD32 - 85	178.4	85	71.8	67	32	71	5/8" - 11	M16 x 2.0P	2.60
85942G	NT50 x MLD32 - 90	216.8	90	71.8	67	32	71	1" - 8	M24 x 3.0P	4.90







Features:

- ▶ Good clamping power. The clamping power of MLD32 type is around 1000 N-m.
- ▶ Runout accuracy of MLD holder body: within 0.005mm.
- ▶ Runout accuracy with collet: within 0.02mm.
- ▶ The tolerance of the cutting tool must be less than h6.
- ▶ Internal bearing cage helps increase the clamping force.
- ▶ After fastening, the nuts and tool holders contact tight to enhance the cutting rigidity.
- ▶ Coolant options: through the center of holder or cutter. Use sealed caps and SR rings for coolant through cutter.

Product information:

- ▶ The pre-balance reaches G6.3 8,000 rpm. Higher balancing grade and revolution can be done upon request but additional charge is needed.
- ▶ AD+B type is available, please inform us when making an order.
- ▶ MAS/BT30 tool holders are without coolant supply over collars.

Standard Accessory: • NUT • SET SCREW

Collet	Sealed Cap	SR Sealed Ring	Set Screw	Spanner	Spanner
					
P.W-32~33	P.W-52	P.W-53	P.W-82	P.W-65~66	P.W-67

EOC COLLET CHUCK



EOC 立銑刀夾頭

(DIN ISO 10897)



T W PAT NO. M298033
 T W PAT NO. M311791
 J P PAT NO. 3128766
 K R PAT NO. 20-0433603
 C N PAT NO. ZL200620132661.0
 C H PAT NO. 696550
 T R PAT NO. TR 2007 02942 Y
 I T PAT NO. N.0000266731

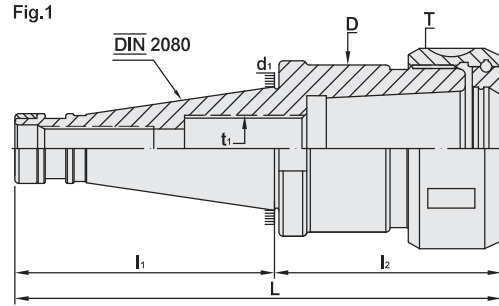

MODEL NO.	TYPE	L	l ₁	l ₂	D	d ₁	t ₁	T	Fig	WEIGHT (KGS)
83676	NT30 x EOC25	140	68.4	71.6	49	31.75	M12 x 1.75P	M48 x 2.0P	1	1.35
83677	NT40 x EOC25	160	93.4	66.6	63	44.45	M16 x 2.0P	M48 x 2.0P	1	1.65
83678	NT50 x EOC25	197	126.8	70.2	97.5	69.85	M24 x 2.0P	M48 x 2.0P	1	3.45
83685	NT40 x EOC32	175	93.4	81.6	63	44.45	M24 x 2.0P	M60 x 2.5P	1	2.25
83686	NT50 x EOC32	196.8	126.8	70	97.5	69.85	M24 x 2.0P	M60 x 2.5P	1	3.95

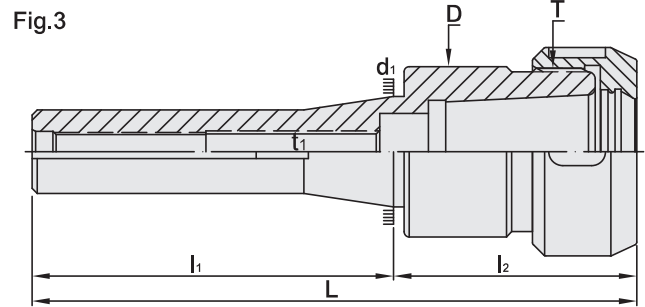
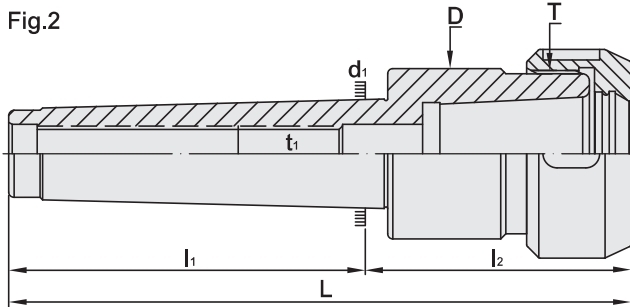

MODEL NO.	TYPE	L	l ₁	l ₂	D	d ₁	t ₁	T	Fig	WEIGHT (KGS)
83672	MTB2 x EOC25	139	64	75	49	17.78	M6 x 1.0P	M48 x 2.0P	2	1.30
83673	MTB3 x EOC25	156	81	75	49	23.825	M12 x 1.75P	M48 x 2.0P	2	1.40
83674	MTB4 x EOC25	179	102.5	76.5	49	31.267	M16 x 2.0P	M48 x 2.0P	2	1.55
83675	R8 x EOC25	174	104	70	49	31.75	M12 x 1.75P	M48 x 2.0P	3	1.55
83682	MTB4 x EOC32	187	102.5	84.5	63	31.267	M16 x 2.0P	M60 x 2.5P	2	2.25
83683	MTB5 x EOC32	213	128.5	78	63	44.399	M24 x 2.0P	M60 x 2.5P	2	2.45

Standard Accessory: • NUT • SPANNER

Collet	Nut	Tang	Preset Screw	Spanner
P.W-35	P.W-51	P.W-75	P.W-82	P.W-62~66



TG COLLET CHUCK



TG 立銑刀夾頭

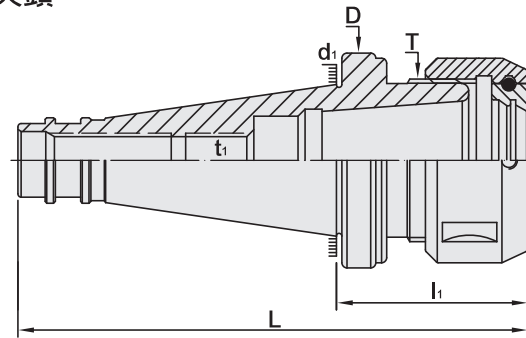

T W PAT NO. M298033
 T W PAT NO. M311791
 J P PAT NO. 3128766
 K R PAT NO. 20-0433603
 C N PAT NO. ZL200620132661.0
 C H PAT NO. 696550
 T R PAT NO. TR 2007 02942 Y
 I T PAT NO. N.0000266731

MODEL NO.	TYPE	L	li	D	di	t ₁	T	SIZE RANGE	WEIGHT (KGS)
84024	MTB3 x TG75	136	55	40	23.825	M12 x 1.75P	TW 1-1/2" - 12	3 ~ 16	0.95
84025	MTB4 x TG75	159.5	57	40	31.267	M16 x 2.0P	TW 1-1/2" - 12	3 ~ 16	1.20
84026	R8 x TG75	154	70	40	31.75	M12 x 1.75P	TW 1-1/2" - 12	3 ~ 16	1.10
84027	NT30 x TG75	123.4	55	49	31.75	M12 x 1.75P	TW 1-1/2" - 12	3 ~ 16	0.90
84028	NT40 x TG75	162	68.6	63	44.45	M16 x 2.0P	TW 1-1/2" - 12	3 ~ 16	1.20
84033	MTB3 x TG100	161	80	49	23.825	M12 x 1.75P	TW 1-7/8" - 12	3 ~ 25	1.05
84034	MTB4 x TG100	182.5	80	49	31.267	M16 x 2.0P	TW 1-7/8" - 12	3 ~ 25	1.30
84035	R8 x TG100	181	80	49	31.75	M12 x 1.75P	TW 1-7/8" - 12	3 ~ 25	1.20
84036	NT30 x TG100	148.4	80	49	31.75	M12 x 1.75P	TW 1-7/8" - 12	3 ~ 25	1.00
84037	NT40 x TG100	163.4	70	63	44.45	M16 x 2.0P	TW 1-7/8" - 12	3 ~ 25	1.30
84038	NT50 x TG100	206.8	80	97.5	69.85	M24 x 2.0P	TW 1-7/8" - 12	3 ~ 25	3.15
84043	MTB4 x TG150	197.5	95	67	31.267	M16 x 2.0P	TW 2-5/8" - 12	4 ~ 38	2.90
84045	MTB5 x TG150	223.5	95	67	44.399	M24 x 2.0P	TW 2-5/8" - 12	4 ~ 38	3.50
84047	NT40 x TG150	191.8	98.36	63	44.45	M24 x 2.0P	TW 2-5/8" - 12	4 ~ 38	2.90
84049	NT50 x TG150	206.8	80	97.5	69.85	M24 x 2.0P	TW 2-5/8" - 12	4 ~ 38	4.75

Features:

- ▶ The body thread treated with grinding.
- ▶ Including nut and spanner.
- ▶ MTB=Draw Bar Type=DIN 228-A.

Standard Accessory: • NUT

Collet	Nut	Tang	Preset Screw	Spanner
P.W-36~38	P.W-51	P.W-75	P.W-82	P.W-66

NT / SLN SIDE LOCK END MILL HOLDER

NT / SLN 側固式立銑刀柄

(DIN 1835)
(DIN 6359)
(DIN 1835-C)

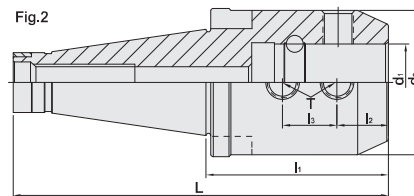
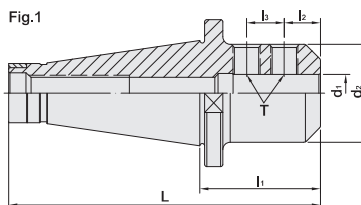

MODEL NO.	TYPE	L	l ₁	l ₂	l ₃	d ₁	d ₂	T	Fig.	WEIGHT (KGS)
83230	NT30 x SLN6 - 40	108.4	40	18	-	6	25	M6 x 1.0P	1	0.50
83231	NT30 x SLN8 - 40	108.4	40	18	-	8	28	M8 x 1.25P	1	0.60
83232	NT30 x SLN10 - 40	108.4	40	20	-	10	35	M10 x 1.5P	1	0.60
83233	NT30 x SLN12 - 50	118.4	50	22.5	-	12	42	M12 x 1.75P	1	0.65
83234	NT30 x SLN16 - 50	118.4	50	24	-	16	48	M14 x 2.0P	1	0.75
83235	NT30 x SLN20 - 63	131.4	63	25	-	20	52	M16 x 2.0P	1	1.10
83236	NT30 x SLN25 - 80	148.4	80	24	25	25	63.5	M18 x 2.0P	1	1.20
83240	NT40 x SLN6 - 50	143.4	50	18	-	6	25	M6 x 1.0P	1	0.90
83241	NT40 x SLN8 - 50	143.4	50	18	-	8	28	M8 x 1.25P	1	0.95
83242	NT40 x SLN10 - 50	143.4	50	20	-	10	35	M10 x 1.5P	1	1.10
83243	NT40 x SLN12 - 50	143.4	50	22.5	-	12	42	M12 x 1.75P	1	1.00
83244	NT40 x SLN16 - 63	156.4	63	24	-	16	48	M14 x 2.0P	1	1.40
83245	NT40 x SLN20 - 63	156.4	63	25	-	20	52	M16 x 2.0P	1	1.45
83246	NT40 x SLN25 - 80	173.4	80	24	25	25	65	M18 x 2.0P	1	2.10
83247	NT40 x SLN32 - 80	173.4	80	24	28	32	72	M20 x 2.0P	1	2.50
83250	NT50 x SLN6 - 63	189.8	63	18	-	6	25	M6 x 1.0P	1	2.90
83251	NT50 x SLN8 - 63	189.8	63	18	-	8	28	M8 x 1.25P	1	3.00
83252	NT50 x SLN10 - 63	189.8	63	20	-	10	35	M10 x 1.5P	1	3.20
83253	NT50 x SLN12 - 63	189.8	63	22.5	-	12	42	M12 x 1.75P	1	3.30
83254	NT50 x SLN16 - 63	189.8	63	24	-	16	48	M14 x 2.0P	1	3.50
83255	NT50 x SLN20 - 63	189.8	63	25	-	20	52	M16 x 2.0P	1	3.60
83256	NT50 x SLN25 - 80	206.8	80	24	25	25	65	M18 x 2.0P	1	4.20
83257	NT50 x SLN32 - 80	206.8	80	24	28	32	72	M20 x 2.0P	1	4.40
83258	NT50 x SLN40 - 100	226.8	100	30	32	40	90	M20 x 2.0P	1	4.40
83261	NT50 x SLN40 - 120	246.8	120	30	32	40	90	M20 x 2.0P	1	4.20
83259	NT50 x SLN42 - 100	226.8	100	30	32	42	90	M20 x 2.0P	1	4.60
83263	NT50 x SLN50 - 120	246.8	120	35	35	50	95	M24 x 2.0P	1	4.80
83265	NT50 x SLN63 - 120	246.8	120	40	40	63	125	M20 x 2.0P	1	5.40
83267	NT50 x SLN50.8 - 120	246.8	120	33.1	28.58	50.8	95	M20 x 2.0P	1	5.00
83269	NT50 x SLN50.8 - 120	246.8	120	33.1	28.58	50.8	95	M20 x 2.0P	2	5.00

Features:

- ▶ Tolerance of internal hole: H5.

Lock Screw



P.W-84



NT FACE MILL ARBOR

NT 平面銑刀柄

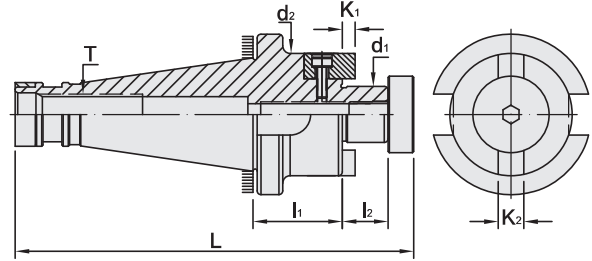

MODEL NO.	TYPE	L	l ₁	l ₂	d ₁	d ₂	K ₁	K ₂	T	WEIGHT (KGS)	
82802	NT30 x FMA25.40	139.4	35	20	25.4	46	4.5	9.52	1/2" - 12	M12 x 1.75P	0.55
82803	NT30 x FMA31.75	141.4	35	22	31.75	60	5.7	12.7	1/2" - 12	M12 x 1.75P	0.75
82804	NT30 x FMA38.10	148.9	35	25	38.1	70	6.87	15.87	1/2" - 12	M12 x 1.75P	2.10
82807	NT40 x FMA25.40	164.4	35	20	25.4	63	4.5	9.52	5/8" - 11	M16 x 2.0P	1.45
82808	NT40 x FMA31.75	166.4	35	22	31.75	63	5.7	12.7	5/8" - 11	M16 x 2.0P	1.75
82809	NT40 x FMA38.10	173.4	35	25	38.1	70	6.87	15.87	5/8" - 11	M16 x 2.0P	2.00
82810	NT40 x FMA50.80	178.4	35	36	50.8	98	9.75	19.05	5/8" - 11	M16 x 2.0P	2.55
82811	NT40 x FMA47.62	149.4	24	32	47.62	128.75	12.5	25.4	5/8" - 11	M16 x 2.0P	2.90
82813	NT50 x FMA25.40	207.8	45	20	25.4	50	4.5	9.52	1" - 8	M24 x 3.0P	3.52
82814	NT50 x FMA31.75	200.8	45	22	31.75	60	5.7	12.7	1" - 8	M24 x 3.0P	3.40
82815	NT50 x FMA38.10	217.3	45	25	38.1	70	6.87	15.87	1" - 8	M24 x 3.0P	3.60
82816	NT50 x FMA50.80	221.8	45	36	50.8	90	9.75	19.05	1" - 8	M24 x 3.0P	6.00
82817	NT50 x FMA47.62	182.8	24	32	47.62	128.75	12.5	25.4	1" - 8	M24 x 3.0P	4.90
82827	NT30 x FMB22mm	136.4	35	19	22	42	4	10	1/2" - 12	M12 x 1.75P	0.67
82828	NT30 x FMB27mm	139.4	35	20	27	60	5	12	1/2" - 12	M12 x 1.75P	1.00
82829	NT30 x FMB32mm	141.4	35	22	32	65	6	14	1/2" - 12	M12 x 1.75P	1.20
82830	NT30 x FMB40mm	148.9	35	25	40	80	7	16	1/2" - 12	M12 x 1.75P	1.40
82831	NT40 x FMB22mm	161.4	35	19	22	48	4	10	5/8" - 11	M16 x 2.0P	1.25
82832	NT40 x FMB27mm	164.4	35	20	27	58	5	12	5/8" - 11	M16 x 2.0P	1.45
82833	NT40 x FMB32mm	166.4	35	22	32	65	6	14	5/8" - 11	M16 x 2.0P	1.70
82834	NT40 x FMB40mm	173.9	35	25	40	80	7	16	5/8" - 11	M16 x 2.0P	4.54
82835	NT50 x FMB22mm	204.8	45	19	22	48	4	10	1" - 8	M24 x 3.0P	3.50
82836	NT50 x FMB27mm	207.8	45	20	27	58	5	12	1" - 8	M24 x 3.0P	3.90
82837	NT50 x FMB32mm	209.8	45	22	32	65	6	14	1" - 8	M24 x 3.0P	4.00
82838	NT50 x FMB40mm	217.3	45	25	40	80	7	16	1" - 8	M24 x 3.0P	4.83

Features:

- ▶ d₁=the external dia. of face mill cutter.
- ▶ There's a plastic ring at the end of the shank to protect machine spindle.
- ▶ When making an order, please inform draw bar size.

NT COMBI SHELL END MILL ARBOR

NT 聯結式銑刀柄

[DIN 6358]

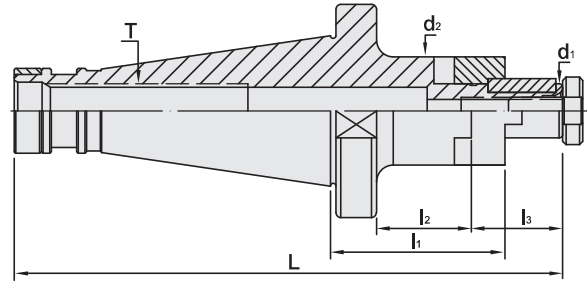

MODEL NO.	TYPE	L	l ₁	l ₂	l ₃	d ₁	d ₂	T		WEIGHT (KGS)
83362	NT30 x CSR16 - 25	120	25	17	27	16	32	1/2" - 12	M12 x 1.75P	1.40
83364	NT30 x CSR22 - 25	122	25	19	31	22	40	1/2" - 12	M12 x 1.75P	1.60
83366	NT30 x CSR27 - 25	124	25	21	33	27	48	1/2" - 12	M12 x 1.75P	1.80
83372	NT40 x CSR16 - 40	162	40	17	27	16	32	5/8" - 11	M16 x 2.0P	2.20
83374	NT40 x CSR22 - 40	164	40	19	31	22	40	5/8" - 11	M16 x 2.0P	2.40
83376	NT40 x CSR27 - 40	166	40	21	33	27	48	5/8" - 11	M16 x 2.0P	2.60
83378	NT40 x CSR32 - 40	169	40	24	38	32	58	5/8" - 11	M16 x 2.0P	2.80
83380	NT40 x CSR40 - 40	172	40	27	41	40	70	5/8" - 11	M16 x 2.0P	3.00
83382	NT50 x CSR16 - 40	199	40	17	27	16	32	1" - 8	M24 x 3.0P	4.40
83384	NT50 x CSR22 - 40	201	40	19	31	22	40	1" - 8	M24 x 3.0P	4.60
83386	NT50 x CSR27 - 40	203	40	21	33	27	48	1" - 8	M24 x 3.0P	4.80
83388	NT50 x CSR32 - 40	206	40	24	38	32	58	1" - 8	M24 x 3.0P	5.00
83390	NT50 x CSR40 - 40	209	40	27	41	40	70	1" - 8	M24 x 3.0P	5.20
83392	NT50 x CSR50 - 40	212	40	30	46	50	90	1" - 8	M24 x 3.0P	5.40

Features:

- ▶ Shank includes removable ring, nut and spanner.
- ▶ Can purchase removable ring, nut, and spanner separately.
- ▶ Please inform the draw bar size when making an order.

Standard Accessory: • KEY • REMOVABLE RING • NUT • SPANNER

Key	Removable Ring	Nut	Spanner
			
P.W-61	P.W-61	P.W-61	P.W-61



SPU DRILL CHUCK

SPU 直結式鑽夾頭

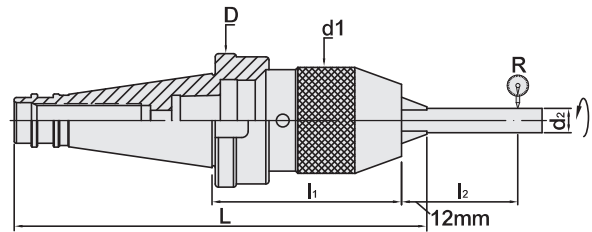

MODEL NO.	TYPE	L	l ₁	l ₂	D	d ₁	d ₂	R	WEIGHT (KGS)
82236	NT30 x SPU13 - 110	190.4	110	55	49	50	5	0.05	1.50
82237	NT40 x SPU13 - 90	195.4	90	55	63	50	10	0.05	1.90
82238	NT50 x SPU13 - 80	218.8	80	75	97.5	50	13	0.05	3.80
82245	NT30 x SPU 8 - 80	160.4	80	55	49	37	5	0.05	1.30
82246	NT40 x SPU8 - 80	185.4	80	55	63	37	5	0.05	1.48
82247	NT40 x SPU16 - 100	205.4	100	75	63	57	13	0.05	2.28
82248	NT50 x SPU16 - 100	238.8	100	75	97.5	57	13	0.05	4.20

Fig.1

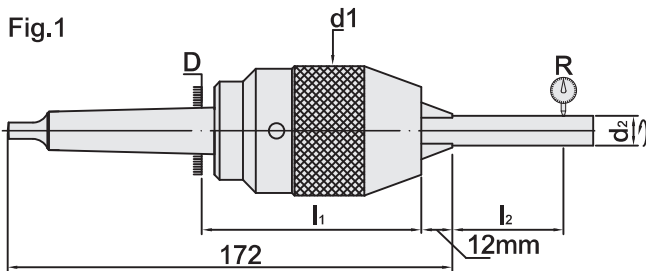
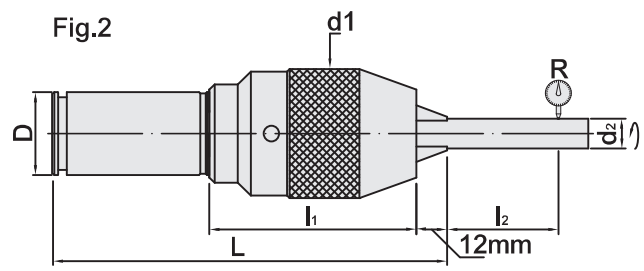

Fig.2



MODEL NO.	TYPE	L	l ₁	l ₂	D	d ₁	d ₂	R	Fig.	WEIGHT (KGS)
82233	MTA3 x SPU13 - 81	162	81	55	50	50	10	0.05	1	1.30
82234	MTA4 x SPU13 - 81	206	81	55	50	50	10	0.05	1	1.65
82229	C20 x SPU8 - 61	121	61	55	20	37	10	0.05	2	1.15
82230	C20 x SPU13 - 81	141	81	55	20	50	10	0.05	2	1.20
82231	C25 x SPU13 - 81	160	81	55	25	50	10	0.05	2	1.30
82232	C32 x SPU13 - 81	162	81	55	32	50	10	0.05	2	1.50
82239	R8 x SPU13 - 81	184	81	55	50	50	10	0.05	-	1.42

KEYLESS DRILL CHUCK	Tang	Spanner
P.W-77	P.W-75	P.W-66



NT DRILL CHUCK ARBOR

NT 夾頭心軸

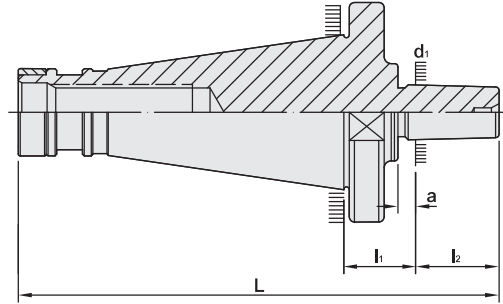

MODEL NO.	TYPE	L	l ₁	l ₂	d ₁	a	WEIGHT (KGS)
81512	NT30 x B16	113	20.6	24	15.733	5	0.35
81513	NT40 x B16	138	20.6	24	15.733	5	0.80
81514	NT50 x B16	176	26.2	24	15.733	5	2.85
81533	NT30 x JT3	118.95	19.6	30.95	20.599	5	0.45
81536	NT30 x JT6	112.4	18.6	25.4	17.17	4	0.40
81543	NT40 x JT3	144.95	20.6	30.95	20.599	5	0.95
81546	NT40 x JT6	139.4	20.6	25.4	17.17	4	0.85
81553	NT50 x JT3	182.95	26.2	30.95	20.599	5	3.00
81556	NT50 x JT6	176.4	24.2	25.4	17.17	4	2.90

Features:

- ▶ Concentricity: 0.005mm.
- ▶ Roundness: 0.005mm.
- ▶ Please inform draw bar size when making an order.

KEYLESS DRILL CHUCK **Spanner**



P.W-77



P.W-66



NT MORSE TAPER ADAPTER

TANG TYPE

NT 斜柄鑽頭套筒

[DIN 6383]

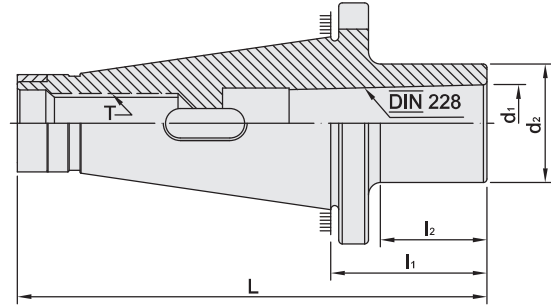

MODEL NO.	TYPE	L	l ₁	l ₂	d ₁	d ₂	T		WEIGHT (KGS)
82900	NT30 x MTA2	123.9	55.5	42	17.78	32	1/2" - 12	M12 x 1.75P	0.50
82901	NT30 x MTA3	144	75.6	63	23.825	36	1/2" - 12	M12 x 1.75P	0.55
82902	NT40 x MTA2	118.4	25	11	17.78	32	5/8" - 11	M16 x 2.0P	0.80
82903	NT40 x MTA3	142	48.6	35	23.825	40	5/8" - 11	M16 x 2.0P	0.85
82904	NT40 x MTA4	177	83.6	69	31.267	48	5/8" - 11	M16 x 2.0P	1.25
82905	NT40 x MTA5	263.4	170	156	44.399	63	5/8" - 11	M16 x 2.0P	1.45
82907	NT50 x MTA2	150	23.2	5.5	17.78	32	1" - 8	M24 x 3.0P	2.80
82908	NT50 x MTA3	160	33.2	13	23.825	40	1" - 8	M24 x 3.0P	2.90
82909	NT50 x MTA4	190	63.2	43	31.267	48	1" - 8	M24 x 3.0P	3.00
82910	NT50 x MTA5	213	86.2	66	44.399	63	1" - 8	M24 x 3.0P	3.10

Features:

- ▶ Hardened & precision ground (I.D & O.D).
- ▶ Roundness: 0.005mm.
- ▶ MTA=TANG TYPE=DIN 228-B.
- ▶ MTB=DRAW BAR TYPE=DIN 228-A.
- ▶ Best selected top quality tools steel fully hardened and ground. Morse taper inside hole and outside shank.
- ▶ Please inform draw bar size when making an order.

NT ADAPTER

NT 套筒

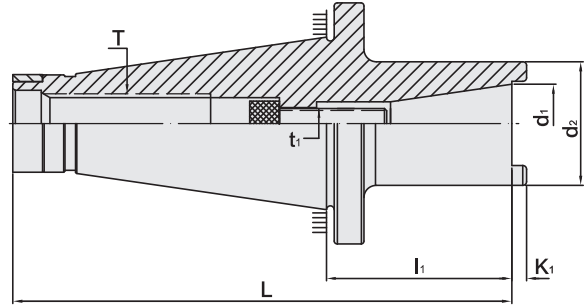

MODEL NO.	TYPE	L	l ₁	d ₁	d ₂	K ₁	t ₁	T		WEIGHT (KGS)
82852	NT40 x TSA30M - 75	174.4	75	31.75	50	6	M12 x 1.75P	5/8" - 11	M16 x 2.0P	1.80
82854	NT40 x TSA30U - 75	174.4	75	31.75	50	6	1/2" - 12	5/8" - 11	M16 x 2.0P	1.80
82856	NT50 x TSA30M - 75	201.8	75	31.75	50	6	M12 x 1.75P	1" - 8	M24 x 3.0P	5.00
82858	NT50 x TSA30U - 75	201.8	75	31.75	50	6	1/2" - 12	1" - 8	M24 x 3.0P	5.00
82860	NT50 x TSA40M - 75	201.8	75	44.45	85	8	M16 x 2.0P	1" - 8	M24 x 3.0P	4.60
82862	NT50 x TSA40U - 75	201.8	75	44.45	85	8	5/8" - 11	1" - 8	M24 x 3.0P	4.60

Features:

- ▶ Please inform the draw bar size when making an order.

