

ISO CATEGORY

ER COLLET CHUCK SYSTEM	J-3
SKS COLLET CHUCK SYSTEM	J-4
SBL SLIM-FIT COLLET CHUCK	J-5
SBLC SLIM-FIT COLLET CHUCK	J-6

TOOLING MEASUREMENT GUIDE FOR SPECIAL ORDERS

When ordering the custom-made ISO tool holders, please offer the following dimensions (shown as the drawing) by filling out the form. Thank you!

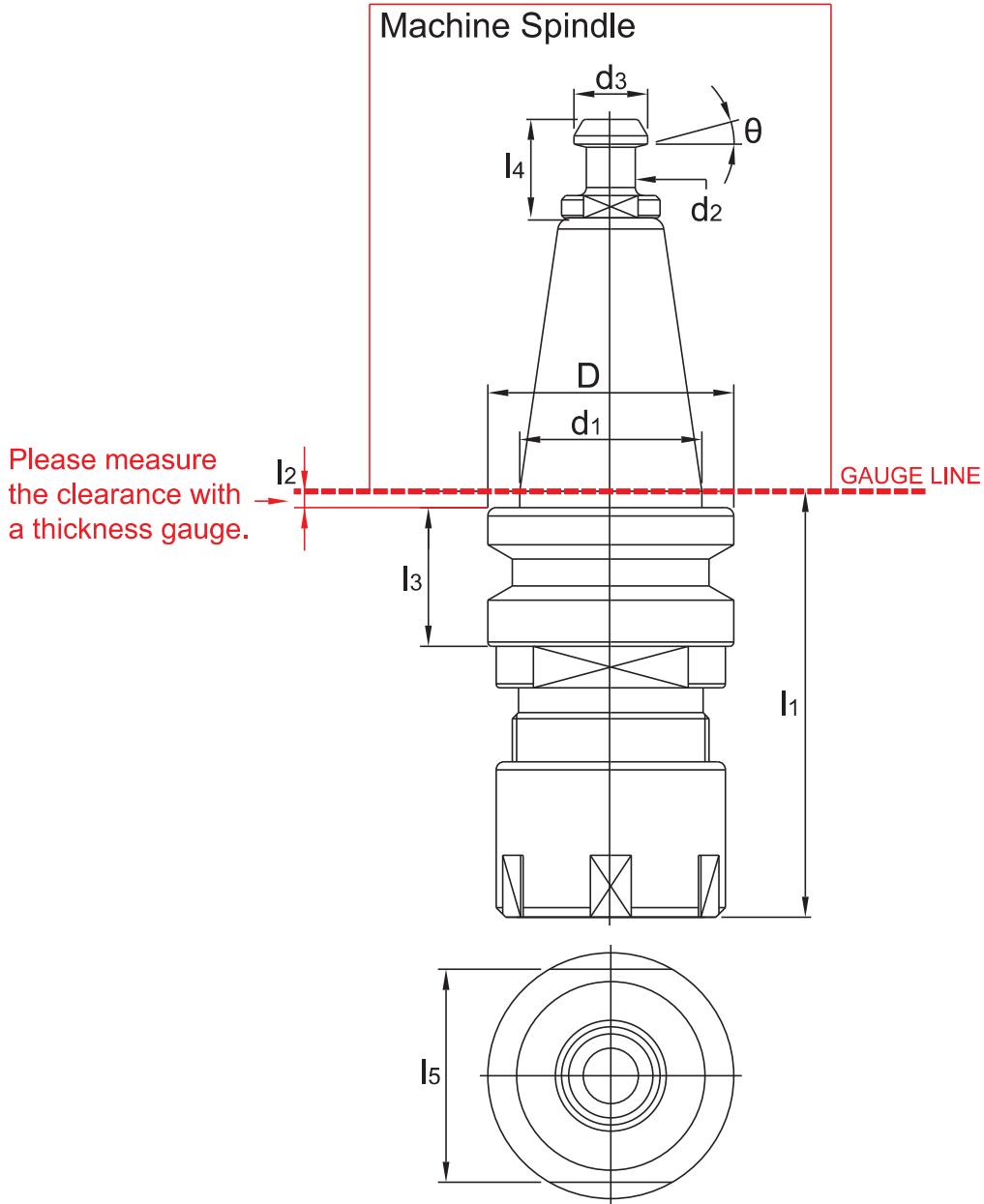

UNIT:mm

TYPE	D	d ₁	d ₂	d ₃	l ₁	l ₂	l ₃	l ₄	l ₅	θ



ISO / ER COLLET CHUCK

W/OUT SLOTS

ISO



ISO / ER 立銑刀夾頭



T W PAT NO. M298033
 T W PAT NO. M311791
 J P PAT NO. 3128766
 K R PAT NO. 20-0433603
 C N PAT NO. ZL200620132661.0
 C H PAT NO. 696550
 T R PAT NO. TR 2007 02942 Y
 I T PAT NO. N.0000266731

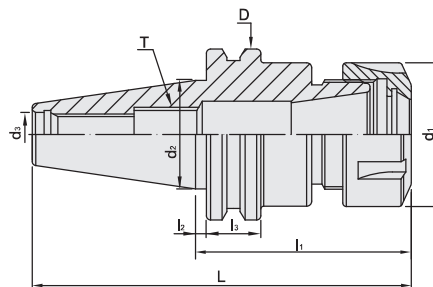

MODEL NO.	TYPE	L	l ₁	l ₂	l ₃	D	d ₁	d ₂	d ₃	T	SIZE RANGE	WEIGHT (KGS)
86102	ISO20 x ER11A - 52	83.3	52	2	8	33	19	21.642	8.5	M6	1 ~ 7	0.55
86103	ISO20 x ER16AD - 52	85.4	52	2	15.9	30	28	22.255	8.5	M10	1 ~ 10	0.60
86104	ISO20 x ER16A - 52	83.3	52	2	8	33	28	21.642	8.5	M10	1 ~ 10	0.60
86105	ISO20 x ER20AD - 52	85.4	52	2	15.9	30	34	22.255	8.5	M10	1 ~ 13	0.65
86106	ISO20 x ER20A - 52	83.3	52	2	8	33	34	21.642	8.5	M12	1 ~ 13	0.65
86112	ISO25 x ER11A - 52	89.7	52	2.95	8	37	19	24.91	8.5	M6	1 ~ 7	0.60
86114	ISO25 x ER16A - 52	89.7	52	2.95	8	37	28	24.91	8.5	M10	1 ~ 10	0.65
86116	ISO25 x ER20A - 52	89.7	52	2.95	8	37	34	24.91	8.5	M12	1 ~ 13	0.70
86122	ISO30 x ER11A - 80	127.8	80	3.2	15.9	50	19	31.75	13	M6	1 ~ 7	0.70
86124	ISO30 x ER16A - 63	110.8	63	3.2	15.9	50	28	31.75	13	M10	1 ~ 10	0.80
86126	ISO30 x ER20A - 63	110.8	63	3.2	15.9	50	34	31.75	13	M12	1 ~ 13	0.85
86128	ISO30 x ER25 - 63	110.8	63	3.2	15.9	50	42	31.75	13	M16	1 ~ 16	0.90
86130	ISO30 x ER32 - 63	110.8	63	3.2	15.9	50	50	31.75	13	M16	2 ~ 20	0.90
86132	ISO30 x ER40 - 57	104.8	57	3.2	15.9	50	63	31.75	13	M16	3 ~ 26	0.95

Features:

- ▶ Whole shank body with grinding.
- ▶ Balance: G2.5 40,000RPM.

Standard Accessory: • NUT

Collet	Nut	Pull Stud	Preset Screw	Spanner
P.W-6~24	P.W-42	P.W-58	P.W-82	P.W-62~65



ISO / SKS COLLET CHUCK

W/OUT SLOTS

ISO / SKS 高速機專用夾頭



T W PAT NO. M270871

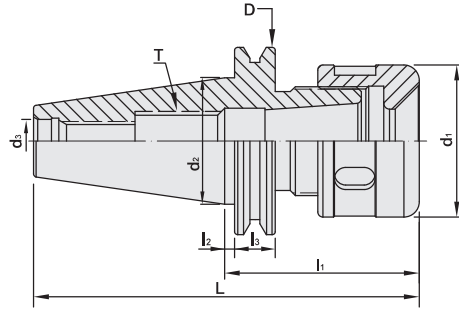

MODEL NO.	TYPE	L	l ₁	l ₂	l ₃	D	d ₁	d ₂	d ₃	T	SIZE RANGE	WEIGHT (KGS)
86852	ISO20 x SKS6 - 45	76.3	45	3.9	8	33	18	21.642	8.5	M8	3 ~ 6	0.55
86854	ISO20 x SKS6 - 60	91.3	60	3.9	8	33	18	21.642	8.5	M8	3 ~ 6	0.60
86856	ISO20 x SKS10 - 45	76.3	45	3.9	8	33	30	21.642	8.5	M12	3 ~ 10	0.60
86858	ISO20 x SKS10 - 60	91.3	60	3.9	8	33	30	21.642	8.5	M12	3 ~ 10	0.70
86862	ISO25 x SKS6 - 45	82.7	45	2.0	8	37	18	25	8.5	M8	3 ~ 6	0.60
86864	ISO25 x SKS6 - 60	97.7	60	2.0	8	37	18	25	8.5	M8	3 ~ 6	0.65
86866	ISO25 x SKS10 - 40	77.7	40	2.0	8	37	30	25	8.5	M12	3 ~ 10	0.70
86868	ISO25 x SKS10 - 60	97.7	60	2.0	8	37	30	25	8.5	M12	3 ~ 10	0.75
86872	ISO30 x SKS6 - 45	92.8	45	3.2	15.9	50	18	31.75	13	M8	3 ~ 6	0.65
86874	ISO30 x SKS6 - 60	107.8	60	3.2	15.9	50	18	31.75	13	M8	3 ~ 6	0.70
86876	ISO30 x SKS10 - 45	92.8	45	3.2	15.9	50	30	31.75	13	M12	3 ~ 10	0.80
86878	ISO30 x SKS10 - 60	107.8	60	3.2	15.9	50	30	31.75	13	M12	3 ~ 10	0.85
86880	ISO30 x SKS16 - 60	107.8	60	3.2	15.9	50	40	31.75	13	M18	3 ~ 16	0.72

Features:

- ▶ Whole shank body with grinding.

Product information:

- ▶ Balance: G2.5 25,000 rpm. Higher balancing grade and revolution can be done upon request but additional charge is needed.

Standard Accessory: • NUT

Collet	Nut	Pull Stud	Preset Screw	Spanner
				
P.W-25~28	P.W-47~48	P.W-58	P.W-82	P.W-62~66

ISO / SBL SLIM-FIT COLLET CHUCK

W/OUT SLOTS

ISO

ISO / SBL 後拉式立銑刀夾頭



T W PAT NO. M274178

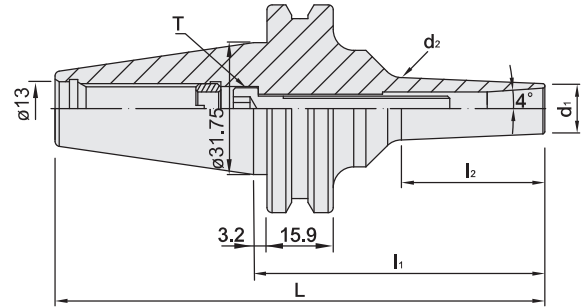





MODEL NO.	TYPE	L	l ₁	l ₂	d ₁	d ₂	T	TORQUE		SIZE RANGE	WEIGHT (KGS)
								N.m	1bf-ft		
86822	ISO30 x SBL6 - 70	117.8	70	39	14	18	M6	12	9	3 ~ 6	0.70
86824	ISO30 x SBL12 - 70	117.8	70	46	26	30	M10	45	33	3 ~ 12	0.80
86826	ISO30 x SBL20 - 80	127.8	80	58	35	37	M12	60	44	3 ~ 20	0.85

Features:

- ▶ Slim designs avoid interference.
- ▶ Chucking in the front part of collet which hides inside.
- ▶ Good design for high speed rotation with good stability because of non-clamping nut.
- ▶ 4° taper angle is good for powerful chucking and can strip easily.

Product information:

- ▶ Balance: G2.5 25,000 rpm. Higher balancing grade and revolution can be done upon request but additional charge is needed.

Collet	Pull Stud	Screw	Spanner
			
P.W-29	P.W-58	P.W-85	P.W-66



ISO / SBLC SLIM-FIT COLLET CHUCK

W/OUT SLOTS

ISO / SBLC 後拉式立銑刀夾頭

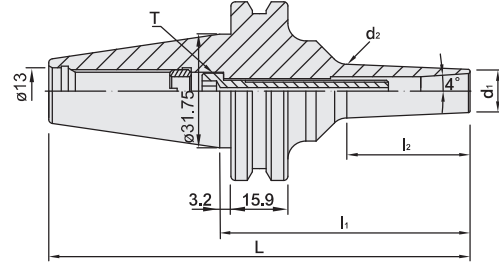

T W PAT NO. M274178

MODEL NO.	TYPE	L	l ₁	l ₂	d ₁	d ₂	T	TORQUE		SIZE RANGE	WEIGHT (KGS)
								N.m	1bf-ft		
86822C	ISO30 x SBLC6 - 70	117.8	70	39	14	18	M6	12	9	3 ~ 6	0.70
86824C	ISO30 x SBLC12 - 70	117.8	70	46	26	30	M10	45	33	3 ~ 12	0.80
86826C	ISO30 x SBLC20 - 80	127.8	80	58	35	37	M12	60	44	3 ~ 20	0.85

Features:

- ▶ Slim designs avoid interference.
- ▶ Chucking in the front part of collet which hides inside.
- ▶ Good design for high speed rotation with good stability because of non-clamping nut.
- ▶ 4° taper angle is good for powerful chucking and can strip easily.

Product information:

- ▶ Balance: G2.5 25,000 rpm. Higher balancing grade and revolution can be done upon request but additional charge is needed.
- ▶ Used with SLC sealed collet and coolant through cutters.

Standard Accessory: • SPANNER

Collet	Pull Stud	Screw	Spanner
P.W-30	P.W-58	P.W-85	P.W-66