

HSK CATEGORY

DIN 69893

A TYPE

PNR COLLET CHUCK	G-3~4
PTER COLLET CHUCK	G-5~6
UT COLLET CHUCK	G-7
ER COLLET CHUCK	G-8~10
SKX COLLET CHUCK	G-11~12
SK3 COLLET CHUCK	G-13
SKS COLLET CHUCK	G-14~15
SBL SLIM-FIT COLLET CHUCK	G-16
SBLC SLIM-FIT COLLET CHUCK	G-17
MLD MULTI - LOCK MILLING CHUCK	G-18~19
EOC COLLET CHUCK	G-20
SLN SIDE LOCK END MILL HOLDER	G-21~22
SLN SIDE LOCK END MILL HOLDER [JIS TYPE]	G-23
SLNB SIDE LOCK END MILL HOLDER	G-24
FACE MILL ARBOR [FMB TYPE]	G-25
FACE MILL ARBOR [FMC TYPE]	G-26
COMBI SHELL END MILL ARBOR	G-27
SPH DRILL CHUCK ADAPTER	G-28
SPU DRILL CHUCK ADAPTER	G-29
SOM SCREWED END MILL HOLDER	G-30
MORSE TAPER ADAPTER	G-31
HSK / PSC ADAPTER	G-32
BLANK	G-33

E TYPE

PTER COLLET CHUCK	G-35
ER COLLET CHUCK	G-36
SKX COLLET CHUCK	G-37
SK3 COLLET CHUCK	G-38

F TYPE

ER COLLET CHUCK	G-40~41
SKX COLLET CHUCK	G-42

T TYPE

EXTERNAL TURNING TOOL	G-45~49
SIDE LOCK HOLDER	G-50~51
EXTERNAL TURNING TOOL HOLDER	G-51~53

REFERENCE DETAILS

DIN 69893 - A

- ▶ Shank body standard : **DIN 69893-1**
- ▶ Taper tolerance < **AT3**
- ▶ Hardness > **HRC 56°**
- ▶ Surface roughness: Ra < **0.25 µm**
- ▶ Roundness < **0.6 µm**
- ▶ Carbon depth > **0.8mm**
- ▶ The shank has pre-balance at G6.3, and can provide precision balance at G2.5.
It can be ordered by request.

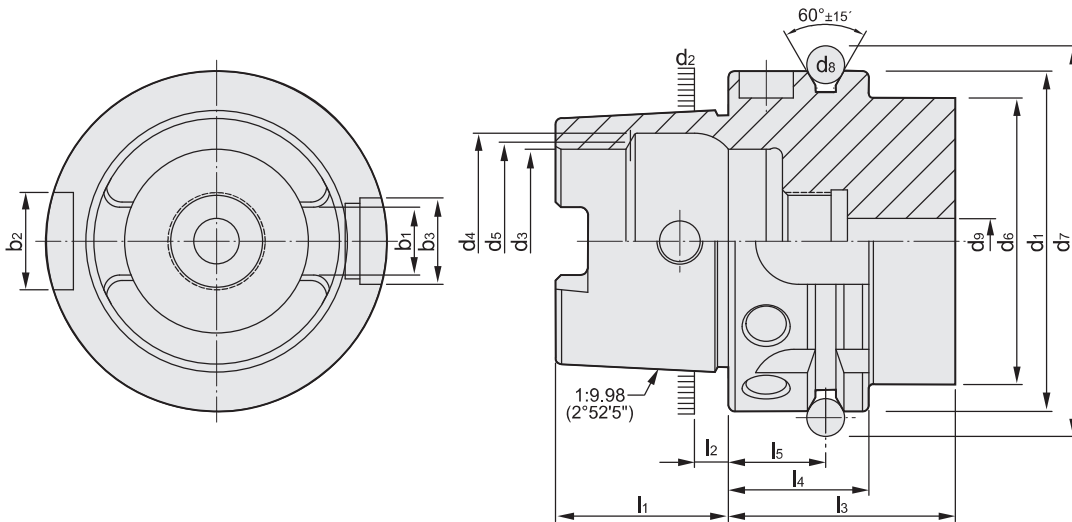

FROM A

HSK	d ₁ h ₁₀	d ₂	d ₃ H ₁₀	d ₄ H ₁₁	d ₅	d ₆ max.	d ₇ 0 -0.1	d ₈	d ₉ max.
25	25	19.006	14	16.4	15	20	28.5	3	3
32	32	24.007	17	20.5	19	26	37	4	4.2
40	40	30.007	21	25.5	23	34	45	4	5
50	50	38.009	26	32	29	42	59.3	7	6.8
63	63	48.010	34	40	37	53	72.3	7	8.4
80	80	60.012	42	50	46	68	88.8	7	10.2
100	100	75.013	53	63	58	88	109.75	7	12
125	125	95.016	67	80	73	111	134.75	7	14
HSK	l ₁ 0 -0.2	l ₂	l ₃ min.	l ₄ 0 -0.1	l ₅ ±0.1	b ₁ ±0.04	b ₂ H ₁₀	b ₃ H ₁₀	
25	13	2.5	20	10	4.5	6.05	6	7	
32	16	3.2	35	20	16	7.05	7	9	
40	20	4	35	20	16	8.05	9	11	
50	25	5	42	26	18	10.54	12	14	
63	32	6.3	42	26	18	12.54	16	18	
80	40	8	42	26	18	16.04	18	20	
100	50	10	45	29	20	20.02	20	22	
125	63	12.5	45	29	20	25.02	25	28	

HSK / PNER COLLET CHUCK



3μm

HSK / PNER 立銑刀夾頭

[DIN 69893-1]



T W PAT NO. M298033
 T W PAT NO. M311791
 T W PAT NO. M501316
 J P PAT NO. 3128766
 J P PAT NO. 3200356
 K R PAT NO. 20-0433603
 C N PAT NO. ZL200620132661.0
 C H PAT NO. 696550
 T R PAT NO. TR 2007 02942 Y
 I T PAT NO. N.0000266731
 D E PAT NO. Nr.202015005621

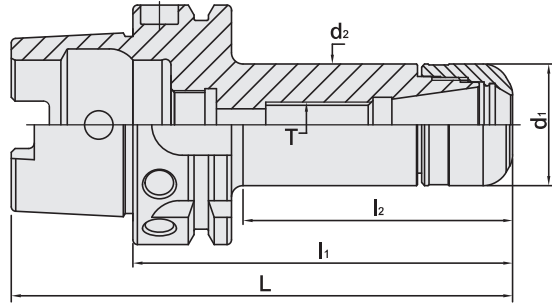

MODEL NO.	TYPE	L	l ₁	l ₂	d ₁	d ₂	T	SIZE RANGE	WEIGHT (KGS)
35710	HSK32A x PNER16 - 50	66	50	29	30	26	-	3 ~ 10	0.14
35711	HSK32A x PNER20 - 60	76	60	39	32	26	-	3 ~ 13	0.24
35720	HSK40A x PNER16 - 60	80	60	37	30	30	-	3 ~ 10	0.36
35722	HSK40A x PNER20 - 60	80	60	38	32	32	-	3 ~ 13	0.37
35724	HSK40A x PNER25 - 60	80	60	39	40	34	-	3 ~ 16	0.47
35726	HSK40A x PNER32 - 70	90	70	35	50	50	-	3 ~ 20	0.57
35730	HSK50A x PNER16 - 60	85	60	31	30	30	-	3 ~ 10	0.54
35732	HSK50A x PNER20 - 60	85	60	31	32	32	-	3 ~ 13	0.55
35734	HSK50A x PNER25 - 60	85	60	33	40	40	-	3 ~ 16	0.65
35736	HSK50A x PNER32 - 70	95	70	42	50	42	-	3 ~ 20	0.75
35738	HSK50A x PNER40 - 80	105	80	38	63	63	-	6 ~ 26	0.85

Product information:

- ▶ Balance: G2.5 25,000 rpm. Higher balancing grade and revolution can be done upon request but additional charge is needed.
- ▶ Use PN 3μm collet.

Standard Accessory: • NUT

Collet	Nut	Coolant Supply Unit	Key	Preset Screw	Spanner
P.W-4	P.W-39	P.W-60	P.W-60	P.W-82	P.W-62~67



HSK / PNER COLLET CHUCK



HSK / PNER 立銑刀夾頭

(DIN 69893-1)



T W PAT NO. M298033
 T W PAT NO. M311791
 T W PAT NO. M501316
 J P PAT NO. 3128766
 J P PAT NO. 3200356
 K R PAT NO. 20-0433603
 C N PAT NO. ZL200620132661.0
 C H PAT NO. 696550
 T R PAT NO. TR 2007 02942 Y
 I T PAT NO. N.000266731
 D E PAT NO. Nr.202015005621

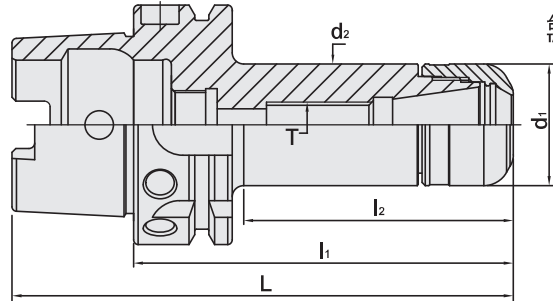

MODEL NO.	TYPE	L	l ₁	l ₂	d ₁	d ₂	T	SIZE RANGE	WEIGHT (KGS)
35742	HSK63A x PNER16 - 60	92	60	31	30	30	-	3 ~ 10	1.00
35742 - 100	HSK63A x PNER16 - 100	132	100	64	30	30	M10 x 1.5P	3 ~ 10	1.10
35742 - 130	HSK63A x PNER16 - 130	162	130	94	30	30	M10 x 1.5P	3 ~ 10	1.20
35742 - 160	HSK63A x PNER16 - 160	192	160	124	30	30	M10 x 1.5P	3 ~ 10	1.30
35744	HSK63A x PNER20 - 60	92	60	31	32	32	-	3 ~ 13	1.60
35744 - 100	HSK63A x PNER20 - 100	132	100	71	32	32	M12 x 1.75P	3 ~ 13	1.70
35744 - 130	HSK63A x PNER20 - 130	162	130	99	32	32	M12 x 1.75P	3 ~ 13	1.80
35744 - 160	HSK63A x PNER20 - 160	192	160	129	32	32	M12 x 1.75P	3 ~ 13	1.90
35746	HSK63A x PNER25 - 100	132	100	71	40	40	M16 x 2.0P	3 ~ 16	1.80
35746 - 130	HSK63A x PNER25 - 130	162	130	101	40	40	M16 x 2.0P	3 ~ 16	1.90
35746 - 160	HSK63A x PNER25 - 160	192	160	131	40	40	M16 x 2.0P	3 ~ 16	2.00
35748	HSK63A x PNER32 - 100	132	100	72	50	50	-	3 ~ 20	2.55
35748 - 130	HSK63A x PNER32 - 130	162	130	101	50	50	M16 x 2.0P	3 ~ 20	2.65
35748 - 160	HSK63A x PNER32 - 160	192	160	131	50	50	M16 x 2.0P	3 ~ 20	2.75
35750	HSK63A x PNER40 - 100	132	100	58	63	63	M20 x 2.0P	6 ~ 26	2.65
35750 - 130	HSK63A x PNER40 - 130	162	130	88	63	63	M20 x 2.0P	6 ~ 26	2.75
35750 - 160	HSK63A x PNER40 - 160	192	160	118	63	63	M20 x 2.0P	6 ~ 26	2.85
35760	HSK80A x PNER32 - 100	140	100	69	50	50	-	3 ~ 20	3.10
35762	HSK80A x PNER40 - 120	160	120	91	63	63	M20 x 2.0P	6 ~ 26	3.12
35766	HSK100A x PNER16 - 100	150	100	61	30	30	M10 x 1.5P	3 ~ 10	2.90
35768	HSK100A x PNER20 - 100	150	100	61	32	32	-	3 ~ 13	3.00
35770	HSK100A x PNER25 - 100	150	100	61	40	40	M16 x 2.0P	3 ~ 16	3.10
35772	HSK100A x PNER32 - 100	150	100	61	50	50	-	3 ~ 20	3.15
35774	HSK100A x PNER40 - 100	150	100	61	63	63	-	6 ~ 26	3.31

Product information:

- ▶ Balance: G2.5 25,000 rpm. Higher balancing grade and revolution can be done upon request but additional charge is needed.
- ▶ Use PN 3µm collet.

Standard Accessory: • NUT

Collet	Nut	Coolant Supply Unit	Key	Preset Screw	Spanner
P.W-4	P.W-39	P.W-60	P.W-60	P.W-82	P.W-62~67



HSK / PTER COLLET CHUCK



HSK / PTER 立銑刀夾頭

(DIN 69893-1)



T W PAT NO. M298033
 T W PAT NO. M311791
 J P PAT NO. 3128766
 J P PAT NO. 3200356
 K R PAT NO. 20-0433603
 C N PAT NO. ZL200620132661.0
 C H PAT NO. 696550
 T R PAT NO. TR 2007 02942 Y
 I T PAT NO. N.0000266731

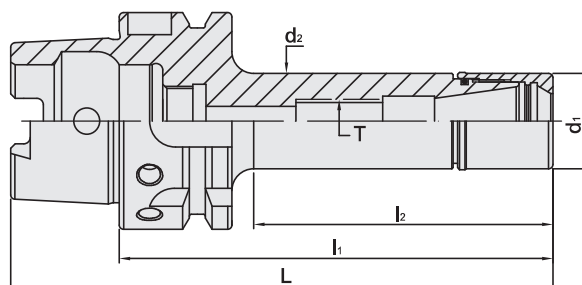

MODEL NO.	TYPE	L	l ₁	l ₂	d ₁	d ₂	T	SIZE RANGE	WEIGHT (KGS)
35816	HSK32A x PTER16 - 50	66	50	28	22	22	-	3 ~ 10	0.16
35818	HSK32A x PTER20 - 60	76	60	39	28	26	-	3 ~ 13	0.22
35820	HSK32A x PTER25 - 65	81	65	44	35	34	-	3 ~ 16	0.26
35826	HSK40A x PTER16 - 50	70	50	29	22	22	-	3 ~ 10	0.24
35828	HSK40A x PTER20 - 55	75	55	34	28	28	-	3 ~ 13	0.28
35830	HSK40A x PTER25 - 65	85	65	44	35	34	-	3 ~ 16	0.37
35834	HSK50A x PTER11 - 46	71	46	19,5	16	16	-	3 ~ 7	0.40
35834 - 70	HSK50A x PTER11 - 70	95	70	39	16	16	M6 x 1.0P	3 ~ 7	0.43
35834 - 100	HSK50A x PTER11 - 100	125	100	64	16	16	M6 x 1.0P	3 ~ 7	0.48
35834 - 125	HSK50A x PTER11 - 125	150	125	84	16	16	M6 x 1.0P	3 ~ 7	0.53
35834 - 150	HSK50A x PTER11 - 150	175	150	109	16	16	M6 x 1.0P	3 ~ 7	0.56
35836	HSK50A x PTER16 - 70	95	70	39	22	22	-	3 ~ 10	0.46
35836 - 100	HSK50A x PTER16 - 100	125	100	69	22	22	M10 x 1.5P	3 ~ 10	0.54
35836 - 125	HSK50A x PTER16 - 125	150	125	94	22	22	M10 x 1.5P	3 ~ 10	0.61
35836 - 150	HSK50A x PTER16 - 150	175	150	119	22	22	M10 x 1.5P	3 ~ 10	0.68
35838 - 70	HSK50A x PTER20 - 70	95	70	39	28	28	-	3 ~ 13	0.52
35838 - 100	HSK50A x PTER20 - 100	125	100	69	28	28	M12 x 1.75P	3 ~ 13	0.63
35838 - 125	HSK50A x PTER20 - 125	150	125	94	28	28	M12 x 1.75P	3 ~ 13	0.75
35838 - 150	HSK50A x PTER20 - 150	175	150	119	28	28	M12 x 1.75P	3 ~ 13	0.86

Product information:

- ▶ Balance: G2.5 25,000 rpm. Higher balancing grade and revolution can be done upon request but additional charge is needed.
- ▶ Use PN-U 5µm collet.

Standard Accessory: • NUT

Collet	Nut	Coolant Supply Unit	Key	Preset Screw	Spanner
P.W-4	P.W-41	P.W-60	P.W-60	P.W-82	P.W-62~67



HSK / PTER COLLET CHUCK



HSK / PTER 立銑刀夾頭

(DIN 69893-1)



T W PAT NO. M298033
 T W PAT NO. M311791
 J P PAT NO. 3128766
 J P PAT NO. 3200356
 K R PAT NO. 20-0433603
 C N PAT NO. ZL200620132661.0
 C H PAT NO. 696550
 T R PAT NO. TR 2007 02942 Y
 I T PAT NO. N.0000266731

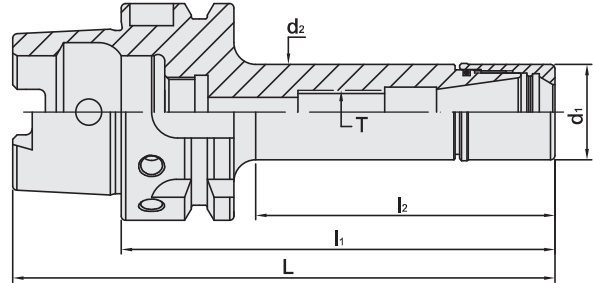

MODEL NO.	TYPE	L	l ₁	l ₂	d ₁	d ₂	T	SIZE RANGE	WEIGHT (KGS)
35844	HSK63A x PTER11 - 70	102	70	39	16	16	M6 x 1.0P	3 ~ 7	0.68
35844 - 100	HSK63A x PTER11 - 100	132	100	64	16	16	M6 x 1.0P	3 ~ 7	0.73
35844 - 125	HSK63A x PTER11 - 125	157	125	84	16	16	M6 x 1.0P	3 ~ 7	0.77
35844 - 150	HSK63A x PTER11 - 150	182	150	109	16	16	M6 x 1.0P	3 ~ 7	0.81
35846	HSK63A x PTER16 - 70	102	70	39	22	22	-	3 ~ 10	0.71
35846 - 100	HSK63A x PTER16 - 100	132	100	69	22	22	M10 x 1.5P	3 ~ 10	0.79
35846 - 125	HSK63A x PTER16 - 125	157	125	89	22	22	M10 x 1.5P	3 ~ 10	0.86
35846 - 150	HSK63A x PTER16 - 150	182	150	114	22	22	M10 x 1.5P	3 ~ 10	0.92
35848	HSK63A x PTER20 - 70	102	70	39	28	28	-	3 ~ 13	0.76
35848 - 100	HSK63A x PTER20 - 100	132	100	69	28	28	M12 x 1.75P	3 ~ 13	0.88
35848 - 125	HSK63A x PTER20 - 125	157	125	89	28	28	M12 x 1.75P	3 ~ 13	1.00
35848 - 150	HSK63A x PTER20 - 150	182	150	114	28	28	M12 x 1.75P	3 ~ 13	1.11

Product information:

- ▶ Balance: G2.5 25,000 rpm. Higher balancing grade and revolution can be done upon request but additional charge is needed.
- ▶ Use PN-U 5µm collet.

Standard Accessory: • NUT

Collet	Nut	Coolant Supply Unit	Key	Preset Screw	Spanner
P,W-4	P,W-41	P,W-60	P,W-60	P,W-82	P,W-62~67



HSK / UT COLLET CHUCK



HSK / UT 立銑刀夾頭

(DIN 69893-1)
(DIN ISO 15488)



T W PAT NO. M298033
T W PAT NO. M311791
J P PAT NO. 3128766
K R PAT NO. 20-0433603
C N PAT NO. ZL200620132661.0
C H PAT NO. 696550
T R PAT NO. TR 2007 02942 Y
I T PAT NO. N.0000266731

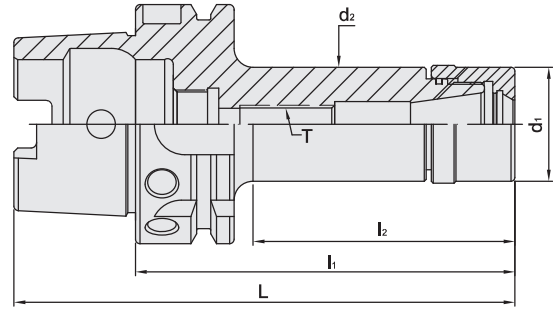

MODEL NO.	TYPE	L	l ₁	l ₂	d ₁	d ₂	T	SIZE RANGE	WEIGHT (KGS)
70.753.16.060	HSK32A x UT16 - 60	76	60	40	30	26	-	1 ~ 10	0.22
70.753.20.070	HSK32A x UT20 - 70	86	70	35	35	36	-	1 ~ 13	0.28
71.753.16.060	HSK40A x UT16 - 60	80	60	38	30	30	-	1 ~ 10	0.31
71.753.20.065	HSK40A x UT20 - 65	85	65	44	48	34	-	1 ~ 13	0.36
72.753.20.060	HSK50A x UT20 - 60	85	60	33	35	36	-	1 ~ 13	0.49
72.753.25.060	HSK50A x UT25 - 60	92	60	34	42	42	-	1 ~ 16	0.51
72.753.25.070	HSK50A x UT25 - 70	102	70	44	42	42	-	1 ~ 16	0.60
72.753.25.100	HSK50A x UT25 - 100	132	100	74	42	42	M16 x 2.0P	1 ~ 16	0.85
72.753.32.075	HSK50A x UT32 - 75	100	75	33	48	42	-	2 ~ 20	0.69
73.753.16.080	HSK63A x UT16 - 80	112	80	49	30	30	M10 x 1.5P	1 ~ 10	0.86
73.753.16.100	HSK63A x UT16 - 100	132	100	69	30	30	M10 x 1.5P	1 ~ 10	0.96
73.753.16.120	HSK63A x UT16 - 120	152	120	89	30	30	M10 x 1.5P	1 ~ 10	1.06
73.753.16.160	HSK63A x UT16 - 160	192	160	124	30	30	M10 x 1.5P	1 ~ 10	1.28
73.753.20.080	HSK63A x UT20 - 80	112	80	49	35	36	M12 x 1.75P	1 ~ 13	0.94
73.753.20.100	HSK63A x UT20 - 100	132	100	69	35	36	M12 x 1.75P	1 ~ 13	1.08
73.753.20.120	HSK63A x UT20 - 120	152	120	89	35	36	M12 x 1.75P	1 ~ 13	1.23
73.753.20.160	HSK63A x UT20 - 160	192	160	129	35	36	M12 x 1.75P	1 ~ 13	1.53
73.753.25.080	HSK63A x UT25 - 80	112	80	49	42	42	M16 x 2.0P	1 ~ 16	1.06
73.753.25.100	HSK63A x UT25 - 100	132	100	69	42	42	M16 x 2.0P	1 ~ 16	1.24
73.753.25.120	HSK63A x UT25 - 120	152	120	89	42	42	M16 x 2.0P	1 ~ 16	1.41
73.753.25.145	HSK63A x UT25 - 145	177	145	114	42	42	M16 x 2.0P	1 ~ 16	1.66
73.753.25.160	HSK63A x UT25 - 160	192	160	129	42	42	M16 x 2.0P	1 ~ 16	1.81
73.753.32.080	HSK63A x UT32 - 80	112	80	52	48	48	-	2 ~ 20	1.13
73.753.32.100	HSK63A x UT32 - 100	132	100	72	48	48	M16 x 2.0P	2 ~ 20	1.33
73.753.32.120	HSK63A x UT32 - 120	152	120	92	48	48	M16 x 2.0P	2 ~ 20	1.59
73.753.32.145	HSK63A x UT32 - 145	177	145	117	48	48	M16 x 2.0P	2 ~ 20	1.91
73.753.32.160	HSK63A x UT32 - 160	192	160	132	48	48	M16 x 2.0P	2 ~ 20	2.11

Product information:

- ▶ Balance: G2.5 25,000 rpm. Higher balancing grade and revolution can be done upon request but additional charge is needed.
- ▶ Use standard ER collets.

Standard Accessory: • NUT

Collet	Nut	Coolant Supply Unit	Key	Preset Screw	Spanner
P.W-6~9	P.W-41	P.W-60	P.W-60	P.W-82	P.W-62~67



HSK / ER COLLET CHUCK



HSK / ER 立銑刀夾頭

[DIN 69893-1]
[DIN ISO 15488]

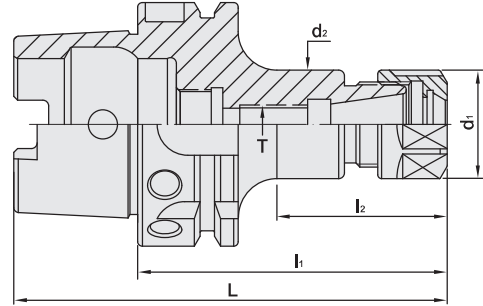

T W PAT NO. M298033
T W PAT NO. M311791
J P PAT NO. 3128766
K R PAT NO. 20-0433603
C N PAT NO. ZL200620132661.0
C H PAT NO. 696550
T R PAT NO. TR 2007 02942 Y
I T PAT NO. N.0000266731

MODEL NO.	TYPE	L	l ₁	l ₂	d ₁	d ₂	T	SIZE RANGE	WEIGHT (KGS)
31378	HSK40A x ER20A - 80	100	80	59	34	32	M10 x 1.5P	1 ~ 13	0.35
31384	HSK40A x ER25 - 80	100	80	59	42	32	M10 x 1.5P	1 ~ 16	0.40
31402	HSK50A x ER16A - 80	105	80	49	28	28	M10 x 1.5P	1 ~ 10	0.50
31404	HSK50A x ER16A - 100	125	100	71	28	28	M10 x 1.5P	1 ~ 10	0.55
31406	HSK50A x ER16A - 120	145	120	91	28	28	M10 x 1.5P	1 ~ 10	0.70
31408	HSK50A x ER20A - 80	105	80	53	34	34	M12 x 1.75P	1 ~ 13	0.60
31410	HSK50A x ER20A - 100	125	100	71	34	34	M12 x 1.75P	1 ~ 13	0.65
31412	HSK50A x ER20A - 120	145	120	91	34	34	M12 x 1.75P	1 ~ 13	0.70
31414	HSK50A x ER25 - 80	105	80	53	42	40	M16 x 2.0P	1 ~ 16	0.70
31416	HSK50A x ER25 - 100	125	100	73	42	42	M16 x 2.0P	1 ~ 16	0.80
31418	HSK50A x ER25 - 135	160	135	108	42	42	M16 x 2.0P	1 ~ 16	0.90
31420	HSK50A x ER32 - 100	125	100	73	50	50	M16 x 2.0P	2 ~ 20	1.35
31422	HSK50A x ER32 - 135	160	135	108	50	50	M16 x 2.0P	2 ~ 20	1.50
31424	HSK50A x ER32 - 160	185	160	133	50	50	M16 x 2.0P	2 ~ 20	1.70

Product information:

► Balance: G2.5 25,000 rpm. Higher balancing grade and revolution can be done upon request but additional charge is needed.

Standard Accessory: • NUT

Collet	Nut	Coolant Supply Unit	Key	Preset Screw	Spanner
P.W-6~24	P.W-42	P.W-60	P.W-60	P.W-82	P.W-62~65



HSK / ER COLLET CHUCK



HSK / ER 立銑刀夾頭

[DIN 69893-1]
[DIN ISO 15488]

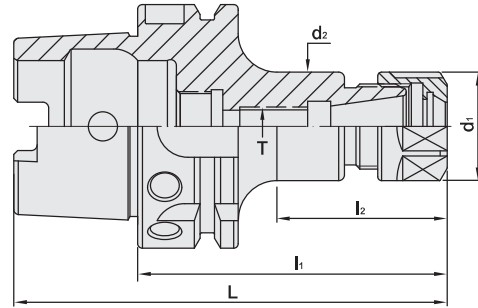

T W PAT NO. M298033
T W PAT NO. M311791
J P PAT NO. 3128766
K R PAT NO. 20-0433603
C N PAT NO. ZL200620132661.0
C H PAT NO. 696550
T R PAT NO. TR 2007 02942 Y
I T PAT NO. N.0000266731

MODEL NO.	TYPE	L	l ₁	l ₂	d ₁	d ₂	T	SIZE RANGE	WEIGHT (KGS)
31432	HSK63A x ER16A - 80	112	80	44	28	28	M10 x 1.5P	1 ~ 10	1.00
31434	HSK63A x ER16A - 100	132	100	64	28	28	M10 x 1.5P	1 ~ 10	1.10
31436	HSK63A x ER16A - 120	152	120	84	28	28	M10 x 1.5P	1 ~ 10	1.70
31438	HSK63A x ER16A - 160	192	160	124	28	28	M10 x 1.5P	1 ~ 10	1.90
31440	HSK63A x ER20A - 80	112	80	49	34	34	M12 x 1.75P	1 ~ 13	1.60
31442	HSK63A x ER20A - 100	132	100	66	34	34	M12 x 1.75P	1 ~ 13	1.70
31444	HSK63A x ER20A - 120	152	120	91	34	34	M12 x 1.75P	1 ~ 13	1.80
31446	HSK63A x ER20A - 160	192	160	131	34	34	M12 x 1.75P	1 ~ 13	2.00
31448	HSK63A x ER25 - 80	112	80	49	42	42	M16 x 2.0P	1 ~ 16	1.70
31450	HSK63A x ER25 - 100	132	100	69	42	42	M16 x 2.0P	1 ~ 16	1.80
31452	HSK63A x ER25 - 120	152	120	89	42	42	M16 x 2.0P	1 ~ 16	2.00
31454	HSK63A x ER25 - 150	182	150	119	42	42	M16 x 2.0P	1 ~ 16	2.30
31456	HSK63A x ER32 - 80	112	80	53	50	50	-	2 ~ 20	1.44
31462	HSK63A x ER32 - 100	132	100	72	50	50	M16 x 2.0P	2 ~ 20	2.55
31464	HSK63A x ER32 - 145	177	145	118	50	50	M16 x 2.0P	2 ~ 20	2.70
31466	HSK63A x ER32 - 160	192	160	133	50	50	M16 x 2.0P	2 ~ 20	3.10
31468	HSK63A x ER40 - 80	112	80	53	63	52	-	3 ~ 26	2.65
31470	HSK63A x ER40 - 100	132	100	58	63	60	M20 x 2.0P	3 ~ 26	1.66
31472	HSK63A x ER40 - 120	152	120	78	63	60	M20 x 2.0P	3 ~ 26	2.77
31474	HSK63A x ER40 - 150	182	150	108	63	60	M20 x 2.0P	3 ~ 26	2.95
31476	HSK63A x ER40 - 170	202	170	128	63	60	M20 x 2.0P	3 ~ 26	3.10
31478	HSK63A x ER50 - 120	152	120	78	78	60	M24 x 2.0P	6 ~ 34	3.50

Product information:

▶ Balance: G2.5 25,000 rpm. Higher balancing grade and revolution can be done upon request but additional charge is needed.

Standard Accessory: • NUT

Collet	Nut	Coolant Supply Unit	Key	Preset Screw	Spanner
P.W-6~24	P.W-42	P.W-60	P.W-60	P.W-82	P.W-62~65



HSK / ER COLLET CHUCK



HSK / ER 立銑刀夾頭

[DIN 69893-1]
[DIN ISO 15488]

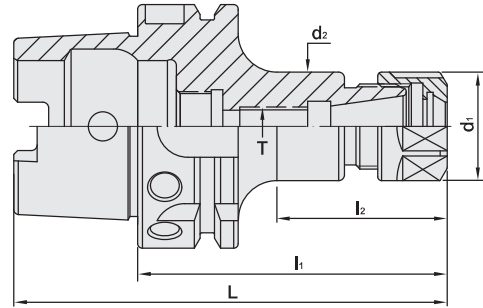

T W PAT NO. M298033
T W PAT NO. M311791
J P PAT NO. 3128766
K R PAT NO. 20-0433603
C N PAT NO. ZL200620132661.0
C H PAT NO. 696550
T R PAT NO. TR 2007 02942 Y
I T PAT NO. N.0000266731

MODEL NO.	TYPE	L	l ₁	l ₂	d ₁	d ₂	T	SIZE RANGE	WEIGHT (KGS)
31482	HSK100A x ER16A - 80	130	80	41	28	28	M10 x 1.5P	1 ~ 10	2.90
31484	HSK100A x ER16A - 100	150	100	61	28	28	M10 x 1.5P	1 ~ 10	2.95
31486	HSK100A x ER16A - 160	210	160	116	28	28	M10 x 1.5P	1 ~ 10	3.45
31488	HSK100A x ER20A - 80	130	80	41	34	34	M12 x 1.75P	1 ~ 13	2.90
31490	HSK100A x ER20A - 100	150	100	61	34	34	M12 x 1.75P	1 ~ 13	3.00
31492	HSK100A x ER20A - 160	210	160	121	34	34	M12 x 1.75P	1 ~ 13	3.30
31494	HSK100A x ER25 - 100	150	100	61	42	42	M16 x 2.0P	1 ~ 16	3.00
31496	HSK100A x ER25 - 130	180	130	96	42	42	M16 x 2.0P	1 ~ 16	3.20
31498	HSK100A x ER32 - 100	150	100	61	50	50	M16 x 2.0P	2 ~ 20	3.15
31500	HSK100A x ER32 - 135	185	135	96	50	50	M16 x 2.0P	2 ~ 20	3.35
31502	HSK100A x ER32 - 150	200	150	116	50	50	M16 x 2.0P	2 ~ 20	3.50
31504	HSK100A x ER40 - 80	130	80	46	63	62	-	3 ~ 26	3.30
31506	HSK100A x ER40 - 120	170	120	86	63	63	M20 x 2.0P	3 ~ 26	3.38
31508	HSK100A x ER40 - 175	225	175	141	63	60	M20 x 2.0P	3 ~ 26	4.20
31510	HSK100A x ER50 - 100	150	100	68	78	78	-	5 ~ 34	4.50
31512	HSK100A x ER50 - 120	170	120	88	78	64	M24 x 2.0P	5 ~ 34	5.00

Product information:

▶ Balance: G2.5 25,000 rpm. Higher balancing grade and revolution can be done upon request but additional charge is needed.

Standard Accessory: • NUT

Collet	Nut	Coolant Supply Unit	Key	Preset Screw	Spanner
P.W-6~24	P.W-42	P.W-60	P.W-60	P.W-82	P.W-62~65



HSK / SKX COLLET CHUCK



HSK / SKX 立銑刀夾頭

(DIN 69893-1)



Fig.1

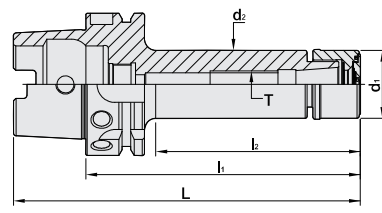
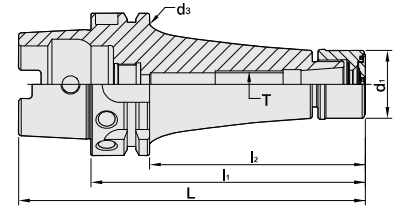

Fig.2



MODEL NO.	TYPE	L	li	lb	d1	d2	d3	T	SIZE RANGE	Fig.	WEIGHT (KGS)
71.790.06.060	HSK40A x SKX6 - 60	80	60	35	18	18	-	M8 x 1,25P	3 ~ 6	1	0,25
71.790.10.075	HSK40A x SKX10 - 75	95	75	53	30	30	-	M12 x 1,75P	3 ~ 10	1	0,38
71.790.16.080	HSK40A x SKX16 - 80	100	80	58	40	40	-	-	3 ~ 16	1	0,44
72.790.06.060	HSK50A x SKX6 - 60	85	60	29	18	18	-	-	3 ~ 6	1	0,41
72.790.06.080	HSK50A x SKX6 - 80	105	80	49	18	18	-	M8 x 1,25P	3 ~ 6	1	0,44
72.790.10.060	HSK50A x SKX10 - 60	85	60	29	30	30	-	-	3 ~ 10	1	0,47
72.790.10.090	HSK50A x SKX10 - 90	115	90	59	30	30	-	M12 x 1,75P	3 ~ 10	1	0,61
72.790.16.080	HSK50A x SKX16 - 80	105	80	53	40	40	-	-	3 ~ 16	1	0,63
72.790.16.105	HSK50A x SKX16 - 105	130	105	78	40	40	-	M18 x 1,5P	3 ~ 16	1	0,83
73.790.06.060	HSK63A x SKX6 - 60	92	60	29	18	18	-	-	3 ~ 6	1	0,66
73.790.06.100	HSK63A x SKX6 - 100	132	100	69	18	18	-	M8 x 1,25P	3 ~ 6	1	0,70
73.790.06.120	HSK63A x SKX6 - 120	152	120	94	18	18	53	M8 x 1,25P	3 ~ 6	2	1,08
73.790.10.060	HSK63A x SKX10 - 60	92	60	29	30	30	-	-	3 ~ 10	1	0,72
73.790.10.105	HSK63A x SKX10 - 105	137	105	74	30	30	-	M12 x 1,75P	3 ~ 10	1	0,93
73.790.10.120	HSK63A x SKX10 - 120	152	120	94	30	30	53	M12 x 1,75P	3 ~ 10	2	1,23
73.790.16.080	HSK63A x SKX16 - 80	112	80	49	40	40	-	-	3 ~ 16	1	0,89
73.790.16.105	HSK63A x SKX16 - 105	137	105	74	40	40	-	M12 x 1,75P	3 ~ 16	1	1,07
73.790.16.120	HSK63A x SKX16 - 120	152	120	94	40	40	53	M18 x 1,5P	3 ~ 16	2	1,29
73.790.20.090	HSK63A x SKX20 - 90	122	90	51	48,5	48,5	-	-	3 ~ 20	1	1,14
73.790.20.105	HSK63A x SKX20 - 105	137	105	66	48,5	48,5	-	-	3 ~ 20	1	1,34
73.790.20.135	HSK63A x SKX20 - 135	167	135	96	48,5	48,5	-	M22 x 1,5P	3 ~ 20	1	1,67
73.790.25.090	HSK63A x SKX25 - 90	122	90	63	55	52	-	-	3 ~ 25,4	1	1,09
73.790.25.135	HSK63A x SKX25 - 135	167	135	108	55	52	-	M28 x 2,0P	3 ~ 25,4	1	1,78

Features:

- ▶ SKX sealed cap is optional. Please order SKX sealed cap additionally.
- ▶ With the design of SKX sealed cap, coolant pressure capable up to 70 bar.
- ▶ Used with coolant-through tools.
- ▶ Balance: G2.5 25,000rpm.

Standard Accessory: • NUT

Collet	Nut	Cap	Preset Screw	Spanner	Sealed Cap Spanner
P.W-25	P.W-49	P.W-50	P.W-82	P.W-62~67	P.W-66



HSK / SKX COLLET CHUCK

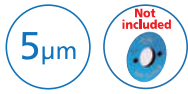

HSK / SKX 立銑刀夾頭

(DIN 69893-1)



Fig.1

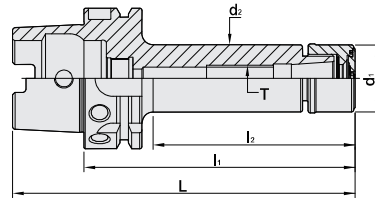
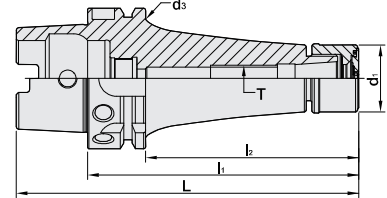

Fig.2



MODEL NO.	TYPE	L	l ₁	l ₂	d ₁	d ₂	d ₃	T	SIZE RANGE	Fig.	WEIGHT (KGS)
75.790.06.105	HSK100A x SKX6 - 105	155	105	61	18	18	-	M8 x 1,25P	3 ~ 6	1	2.08
75.790.10.105	HSK100A x SKX10 - 105	155	105	61	30	30	-	M12 x 1.75P	3 ~ 10	1	0.28
75.790.10.120	HSK100A x SKX10 - 120	170	120	76	30	30	-	M12 x 1.75P	3 ~ 10	1	2.35
75.790.10.150	HSK100A x SKX10 - 150	200	150	106	30	30	-	M12 x 1.75P	3 ~ 10	1	2.50
75.790.16.105	HSK100A x SKX16 - 105	155	105	61	40	40	-	M18 x 1.5P	3 ~ 16	1	2.45
75.790.16.120	HSK100A x SKX16 - 120	170	120	76	40	40	-	M18 x 1.5P	3 ~ 16	1	2.56
75.790.16.150	HSK100A x SKX16 - 150	200	150	106	40	40	-	M18 x 1.5P	3 ~ 16	1	2.80
75.790.20.120	HSK100A x SKX20 - 120	170	120	81	48.5	48.5	-	M22 x 1.5P	3 ~ 20	1	2.80
75.790.20.150	HSK100A x SKX20 - 150	200	150	111	48.5	48.5	-	M22 x 1.5P	3 ~ 20	1	3.15
75.790.20.200	HSK100A x SKX20 - 200	250	200	171	48.5	48.5	88	M22 x 1.5P	3 ~ 20	2	4.82
75.790.25.120	HSK100A x SKX25 - 120	170	120	81	55	55	-	M28 x 2.0P	3 ~ 25.4	1	2.88
75.790.25.145	HSK100A x SKX25 - 145	195	145	106	55	55	-	M28 x 2.0P	3 ~ 25.4	1	3.21

Features:

- ▶ SKX sealed cap is optional. Please order SKX sealed cap additionally.
- ▶ With the design of SKX sealed cap, coolant pressure capable up to 70 bar.
- ▶ Used with coolant-through tools.
- ▶ Balance: G2.5 25,000rpm.

Standard Accessory: • NUT

Collet	Nut	Cap	Preset Screw	Spanner	Sealed Cap Spanner
P.W-25	P.W-49	P.W-50	P.W-82	P.W-62~67	P.W-66



HSK / SK3 COLLET CHUCK

5 μ m

HSK / SK3 高速機專用夾頭

(DIN 69893-1)

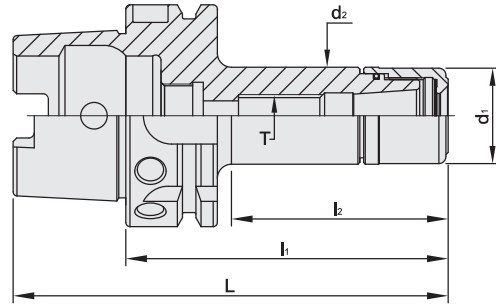

MODEL NO.	TYPE	L	l ₁	l ₂	d ₁	d ₂	T	SIZE RANGE	WEIGHT (KGS)
70.763.06.045	HSK32A x SK306 - 45	77	45	24	19.5	19.5	-	3 ~ 6	0.50
70.763.06.060	HSK32A x SK306 - 60	92	60	37	19.5	19.5	M8 x 1.25P	3 ~ 6	0.70
70.763.10.060	HSK32A x SK310 - 60	92	60	39	27.5	27.5	-	3 ~ 10	0.70
73.763.06.090	HSK63A x SK306 - 90	122	90	61	19.5	19.5	M8 x 1.25P	3 ~ 6	1.20
73.763.10.090	HSK63A x SK310 - 90	122	90	54	27.5	27.5	M12 x 1.75P	3 ~ 10	1.20
73.763.10.120	HSK63A x SK310 - 120	152	120	84	27.5	27.5	M12 x 1.75P	3 ~ 10	1.40
73.763.13.070	HSK63A x SK313 - 70	102	70	39	33	33	-	3 ~ 13	1.00
73.763.13.105	HSK63A x SK313 - 105	137	105	76	33	33	M12 x 1.75P	3 ~ 13	1.10
73.763.13.120	HSK63A x SK313 - 120	152	120	91	33	33	M12 x 1.75P	3 ~ 13	1.30
73.763.16.090	HSK63A x SK316 - 90	122	90	61	40	40	-	3 ~ 16	1.20
73.763.16.120	HSK63A x SK316 - 120	152	120	91	40	40	M18 x 1.5P	3 ~ 16	1.30
75.763.06.100	HSK100A x SK306 - 100	150	100	61	19.5	19.5	M8 x 1.25P	3 ~ 6	1.50
75.763.10.100	HSK100A x SK310 - 100	150	100	61	27.5	27.5	M12 x 1.75P	3 ~ 10	1.60
75.763.13.105	HSK100A x SK313 - 105	155	105	66	33	33	M12 x 1.75P	3 ~ 13	1.70
75.763.13.120	HSK100A x SK313 - 120	170	120	81	33	33	M12 x 1.75P	3 ~ 13	1.80
75.763.13.150	HSK100A x SK313 - 150	200	150	111	33	33	M12 x 1.75P	3 ~ 13	1.50
75.763.16.105	HSK100A x SK316 - 105	155	105	66	40	40	M18 x 1.5P	3 ~ 16	1.70

Product information:

► Balance: G2.5 25,000 rpm. Higher balancing grade and revolution can be done upon request but additional charge is needed.

Standard Accessory: • NUT

Collet	Nut	Coolant Supply Unit	key	Preset Screw	Spanner
P.W-25~28	P.W-46	P.W-60	P.W-60	P.W-82	P.W-62~67



HSK / SKS COLLET CHUCK

5 μ m

HSK / SKS 高速機專用夾頭

(DIN 69893-1)

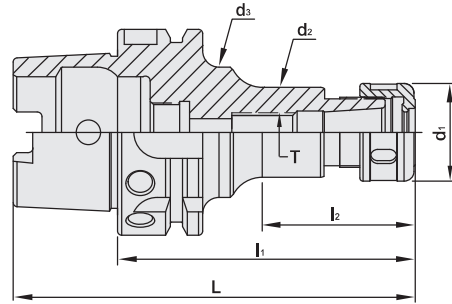

MODEL NO.	TYPE	L	l ₁	l ₂	d ₁	d ₂	d ₃	T	SIZE RANGE	WEIGHT (KGS)
35506	HSK50A x SKS6 - 90	115	90	44	18	18	32	M8 x 1.25P	3 ~ 6	0.80
35508	HSK50A x SKS6 - 120	145	120	74	18	18	32	M8 x 1.25P	3 ~ 6	1.00
35512	HSK50A x SKS10 - 90	115	90	45	30	27.6	40	M12 x 1.75P	3 ~ 10	0.80
35514	HSK50A x SKS10 - 120	145	120	75	30	27.6	40	M12 x 1.75P	3 ~ 10	1.00
35515	HSK50A x SKS13 - 70	95	70	43	35	33	-	-	3 ~ 13	0.90
35515 - 105	HSK50A x SKS13 - 105	130	105	76	35	33	-	M12 x 1.75P	3 ~ 13	1.20
35516	HSK50A x SKS16 - 90	115	90	63	40	40	-	M18 x 1.5P	3 ~ 16	1.00
35517	HSK50A x SKS16 - 120	145	120	93	40	40	-	M18 x 1.5P	3 ~ 16	1.20
35518	HSK50A x SKS20 - 90	115	90	48	48.5	48.5	-	-	3 ~ 20	1.00
35518 - 120	HSK50A x SKS20 - 120	145	120	78	48.5	48.5	-	M22x 1.5P	3 ~ 20	1.20
35519	HSK50A x SKS25 - 90	115	90	63	55	42	-	-	3 ~ 25.4	1.30
35520	HSK50A x SKS25 - 120	145	120	93	55	42	-	M28 x 2.0P	3 ~ 25.4	1.40

Product information:

► Balance: G2.5 25,000 rpm. Higher balancing grade and revolution can be done upon request but additional charge is needed.

Standard Accessory: • NUT

Collet	Nut	Coolant Supply Unit	key	Preset Screw	Spanner
P.W-25~28	P.W-47~48	P.W-60	P.W-60	P.W-82	P.W-62~67

HSK / SKS COLLET CHUCK

5 μ m

HSK / SKS 高速機專用夾頭

[DIN 69893-1]

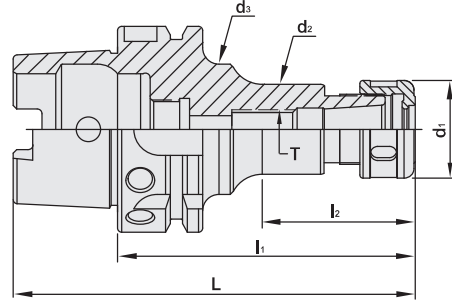

MODEL NO.	TYPE	L	l ₁	l ₂	d ₁	d ₂	d ₃	T	SIZE RANGE	WEIGHT (KGS)
35521	HSK63A x SKS6 - 90	122	90	44	18	18	32	M8 x 1.25P	3 ~ 6	1.00
35522	HSK63A x SKS10 - 90	122	90	45	30	27.6	40	M12 x 1.75P	3 ~ 10	1.00
35524	HSK63A x SKS10 - 120	152	120	75	30	27.6	40	M12 x 1.75P	3 ~ 10	1.80
35525	HSK63A x SKS13 - 70	102	70	43	35	33	-	-	3 ~ 13	0.90
35525 - 105	HSK63A x SKS13 - 105	137	105	74	35	33	-	M12 x 1.75P	3 ~ 13	1.20
35525 - 120	HSK63A x SKS13 - 120	152	120	89	35	33	-	M12 x 1.75P	3 ~ 13	1.50
35526	HSK63A x SKS16 - 90	122	90	59	40	40	-	M18 x 1.5P	3 ~ 16	2.00
35528	HSK63A x SKS16 - 120	152	120	89	40	40	-	M18 x 1.5P	3 ~ 16	2.20
35530	HSK63A x SKS20 - 90	122	90	63	48.5	48.5	-	-	3 ~ 20	1.40
35530 - 105	HSK63A x SKS20 - 105	137	105	78	48.5	48.5	-	M22 x 1.5P	3 ~ 20	1.60
35530 - 120	HSK63A x SKS20 - 120	152	120	93	48.5	48.5	-	M22 x 1.5P	3 ~ 20	1.80
35530 - 135	HSK63A x SKS20 - 135	167	135	108	48.5	48.5	-	M22 x 1.5P	3 ~ 20	2.00
35536	HSK63A x SKS25 - 90	122	90	63	55	52	-	-	3 ~ 25.4	2.20
35538	HSK63A x SKS25 - 120	152	120	93	55	52	-	M28 x 2.0P	3 ~ 25.4	2.30
35550	HSK100A x SKS6 - 100	150	100	44	18	18	32	M8 x 1.25P	3 ~ 6	1.20
35552	HSK100A x SKS10 - 100	150	100	45	30	27.6	40	M12 x 1.75P	3 ~ 10	2.60
35553	HSK100A x SKS13 - 105	155	105	71	35	33	-	M12 x 1.75P	3 ~ 13	2.70
35553 - 120	HSK100A x SKS13 - 120	170	120	86	35	33	-	M12 x 1.75P	3 ~ 13	3.10
35553 - 150	HSK100A x SKS13 - 150	200	150	88	35	33	45	M12 x 1.75P	3 ~ 13	3.40
35554	HSK100A x SKS16 - 105	155	105	66	40	40	-	M18 x 1.5P	3 ~ 16	2.70
35555	HSK100A x SKS20 - 120	170	120	86	48.5	48.5	-	M22 x 1.5P	3 ~ 20	3.10
35555 - 150	HSK100A x SKS20 - 150	200	150	116	48.5	48.5	-	M22 x 1.5P	3 ~ 20	3.50
35555 - 200	HSK100A x SKS20 - 200	250	200	166	48.5	48.5	-	M22 x 1.5P	3 ~ 20	4.20
35556	HSK100A x SKS25 - 120	170	120	81	55	52	-	M28 x 2.0P	3 ~ 25.4	3.40

Product information:

► Balance: G2.5 25,000 rpm. Higher balancing grade and revolution can be done upon request but additional charge is needed.

Standard Accessory: • NUT

Collet	Nut	Coolant Supply Unit	key	Preset Screw	Spanner
P.W-25~28	P.W-47~48	P.W-60	P.W-60	P.W-82	P.W-62~67



HSK / SBL SLIM-FIT COLLET CHUCK

HSK / SBL 後拉式立銑刀夾頭

(DIN 69893-1)

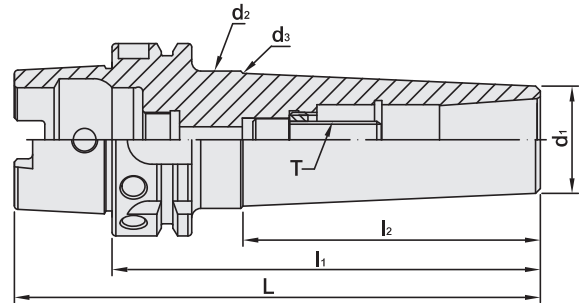

T W PAT NO. M274178

MODEL NO.	TYPE	L	l ₁	l ₂	d ₁	d ₂	d ₃	T	TORQUE		SIZE RANGE	WEIGHT (KGS)
									N.m	1bf-ft		
35452	HSK50A x SBL6 - 80	105	80	44	14	18	-	M6 x 1.0P	12	9	3 ~ 6	1.40
35454	HSK50A x SBL6 - 120	145	120	84	14	22	-	M6 x 1.0P	12	9	3 ~ 6	1.50
35456	HSK50A x SBL12 - 110	135	110	65	26	42	36	M10 x 1.5P	45	33	3 ~ 12	1.50
35458	HSK50A x SBL12 - 130	155	130	86	26	42	39	M10 x 1.5P	45	33	3 ~ 12	1.85
35460	HSK50A x SBL20 - 120	145	120	93	35	42	-	M12 x 1.75P	60	44	3 ~ 20	1.80
35462	HSK50A x SBL20 - 150	175	150	123	35	42	-	M12 x 1.75P	60	44	3 ~ 20	2.00
35470	HSK63A x SBL6 - 80	112	80	39	14	18	-	M6 x 1.0P	12	9	3 ~ 6	1.70
35472	HSK63A x SBL6 - 120	152	120	79	14	22	-	M6 x 1.0P	12	9	3 ~ 6	1.90
35474 - 130	HSK63A x SBL8 - 130	162	130	94.6	20	29.8	-	M8 x 1.25P	29	21	3 ~ 8	0.99
35474 - 150	HSK63A x SBL8 - 150	182	150	114.6	20	32.0	-	M8 x 1.25P	29	21	3 ~ 8	1.11
35476	HSK63A x SBL12 - 110	142	110	79	26	37	-	M10 x 1.5P	45	33	3 ~ 12	1.80
35478	HSK63A x SBL12 - 150	182	150	119	26	42	-	M10 x 1.5P	45	33	3 ~ 12	2.00
35480	HSK63A x SBL20 - 120	152	120	89	35	42	-	M12 x 1.75P	60	44	3 ~ 20	2.00
35482	HSK63A x SBL20 - 140	172	140	97	35	45	43	M12 x 1.75P	60	44	3 ~ 20	2.45
35492	HSK100A x SBL6 - 120	170	120	76	14	22	-	M6 x 1.0P	12	9	3 ~ 6	2.15
35493 - 130	HSK100A x SBL8 - 130	180	130	91.5	20	29.5	-	M8 x 1.25P	29	21	3 ~ 8	2.31
35493 - 150	HSK100A x SBL8 - 150	200	150	111	20	31.6	-	M8 x 1.25P	29	21	3 ~ 8	2.43
35494	HSK100A x SBL12 - 120	170	120	81	26	37	-	M10 x 1.5P	45	33	3 ~ 12	2.40
35496	HSK100A x SBL20 - 135	185	135	88	35	45	42	M12 x 1.75P	60	44	3 ~ 20	2.74
35498	HSK100A x SBL25 - 150	200	150	111	40	49	-	M16 x 1.5P	90	66	6 ~ 25.4	2.80

Product information:

► Balance: G2.5 25,000 rpm. Higher balancing grade and revolution can be done upon request but additional charge is needed.

Collet	Coolant Supply Unit	Key	Screw	Spanner
P.W-29	P.W-60	P.W-60	P.W-85	P.W-66



HSK / SBLC SLIM-FIT COLLET CHUCK

HSK / SBLC 後拉式立銑刀夾頭

(DIN 69893-1)



T W PAT NO. M274178

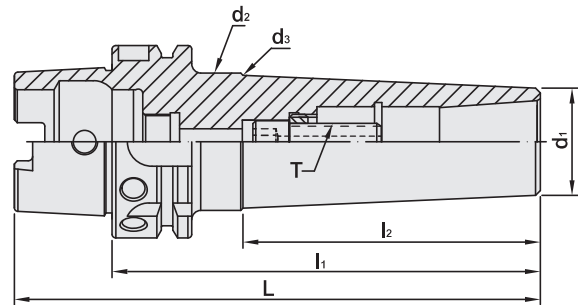

MODEL NO.	TYPE	L	l ₁	l ₂	d ₁	d ₂	d ₃	T	TORQUE		SIZE RANGE	WEIGHT (KGS)
									N.m	1bf-ft		
35452C	HSK50A x SBLC6 - 80	105	80	44	14	18	-	M6 x 1.0P	12	9	3 ~ 6	1.40
35454C	HSK50A x SBLC6 - 120	145	120	84	14	22	-	M6 x 1.0P	12	9	3 ~ 6	1.50
35456C	HSK50A x SBLC12 - 110	135	110	65	26	42	36	M10 x 1.5P	45	33	3 ~ 12	1.50
35458C	HSK50A x SBLC12 - 130	155	130	86	26	42	39	M10 x 1.5P	45	33	3 ~ 12	1.85
35460C	HSK50A x SBLC20 - 120	145	120	93	35	42	-	M12 x 1.75P	60	44	3 ~ 20	1.80
35462C	HSK50A x SBLC20 - 150	175	150	123	35	42	-	M12 x 1.75P	60	44	3 ~ 20	2.00
35470C	HSK63A x SBLC6 - 80	112	80	39	14	18	-	M6 x 1.0P	12	9	3 ~ 6	1.70
35472C	HSK63A x SBLC6 - 120	152	120	79	14	22	-	M6 x 1.0P	12	9	3 ~ 6	1.90
35474C - 130	HSK63A x SBLC8 - 130	162	130	94.6	20	29.8	-	M8 x 1.25P	29	21	3 ~ 8	0.99
35474C - 150	HSK63A x SBLC8 - 150	182	150	114.6	20	32.0	-	M8 x 1.25P	29	21	3 ~ 8	1.11
35476C	HSK63A x SBLC12 - 110	142	110	79	26	37	-	M10 x 1.5P	45	33	3 ~ 12	1.80
35478C	HSK63A x SBLC12 - 150	182	150	119	26	42	-	M10 x 1.5P	45	33	3 ~ 12	2.00
35480C	HSK63A x SBLC20 - 120	152	120	89	35	42	-	M12 x 1.75P	60	44	3 ~ 20	2.00
35482C	HSK63A x SBLC20 - 140	172	140	97	35	45	43	M12 x 1.75P	60	44	3 ~ 20	2.45
35492C	HSK100A x SBLC6 - 120	170	120	76	14	22	-	M6 x 1.0P	12	9	3 ~ 6	2.15
35493C - 130	HSK100A x SBLC8 - 130	180	130	91.5	20	29.5	-	M8 x 1.25P	29	21	3 ~ 8	2.31
35493C - 150	HSK100A x SBLC8 - 150	200	150	111	20	31.6	-	M8 x 1.25P	29	21	3 ~ 8	2.43
35494C	HSK100A x SBLC12 - 120	170	120	81	26	37	-	M10 x 1.5P	45	33	3 ~ 12	2.40
35496C	HSK100A x SBLC20 - 135	185	135	88	35	45	42	M12 x 1.75P	60	44	3 ~ 20	2.74
35498C	HSK100A x SBLC25 - 150	200	150	111	40	49	-	M16 x 1.5P	90	66	6 ~ 25.4	2.80

Product information:

- ▶ Balance: G2.5 25,000 rpm. Higher balancing grade and revolution can be done upon request but additional charge is needed.
- ▶ Used with SLC sealed collet and coolant through cutters.

Standard Accessory: • SPANNER

Collet	Coolant Supply Unit	Key	Screw	Spanner
P.W-30	P.W-60	P.W-60	P.W-85	P.W-66



HSK / MLD MULTI - LOCK MILLING CHUCK

HSK / MLD 直式筒夾銑床夾頭

(DIN 69893-1)



T W PAT NO. M447277
 T W PAT NO. M430337
 T W PAT NO. M451185
 C N PAT NO. ZL201220749784.4
 C H PAT NO. ZL201220749942.6

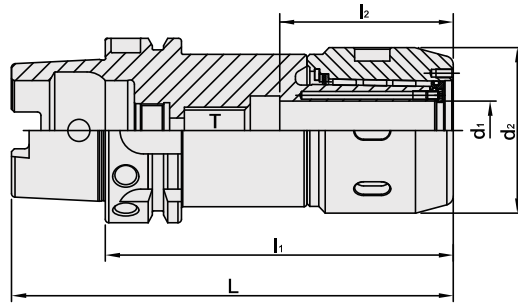

MODEL NO.	TYPE	L	l ₁	l ₂	d ₁	d ₂	T	WEIGHT (KGS)
35310G	HSK50A x MLD12 - 90	115	90	46.7	12	42	-	1.52
35311G	HSK50A x MLD16 - 100	125	100	56.7	16	48	-	1.59
35312G	HSK50A x MLD20 - 120	145	120	59.3	20	56.5	M12 x 1.75P	1.62
35314G	HSK50A x MLD25 - 120	145	120	58.2	25	60	-	1.60
35316G	HSK50A x MLD32 - 130	150	130	71.7	32	71	-	1.80
35318G	HSK63A x MLD12 - 90	122	90	46.7	12	42	-	1.62
35320G	HSK63A x MLD16 - 100	132	100	56.7	16	48	-	1.62
35322G	HSK63A x MLD20 - 120	152	120	59.3	20	56.5	M16 x 2.0P	1.68
35330G	HSK63A x MLD25 - 105	137	105	58.2	25	60	-	1.82
35332G	HSK63A x MLD32 - 120	152	120	71.7	32	71	-	1.76
35348G	HSK100A x MLD12 - 115	165	115	46.7	12	42	M12 x 1.75P	3.10
35350G	HSK100A x MLD16 - 120	170	120	56.7	16	48	M12 x 1.75P	3.10
35352G	HSK100A x MLD20 - 120	170	120	59.3	20	56.5	M16 x 2.0P	3.40
35354G	HSK100A x MLD25 - 115	165	115	58.2	25	60	-	3.30
35356G	HSK100A x MLD32 - 120	170	120	71.7	32	71	-	3.40

Features:

- ▶ Good clamping power. The clamping power of MLD32 type is around 1000 N-m.
- ▶ Runout accuracy of MLD holder body: within 0.005mm.
- ▶ Runout accuracy with collet: within 0.02mm.
- ▶ The tolerance requirement of tool shank diameter is h6.
- ▶ Internal bearing cage helps increase the clamping force.
- ▶ After fastening, the nuts and tool holders contact tight to enhance the cutting rigidity.
- ▶ Coolant options: through the center of holder or cutter. Use sealed caps and SR rings for coolant through cutter.

Product information:

- ▶ The pre-balance reaches G6.3 8,000 rpm. Higher balancing grade and revolution can be done upon request but additional charge is needed.

Standard Accessory: • NUT • SET SCREW

Collet	Sealed Cap	SR Sealed Ring	Coolant Supply Unit	Key	Set Screw	Spanner	Spanner
P.W-32~33	P.W-52	P.W-53	P.W-60	P.W-60	P.W-82	P.W-65~66	P.W-67



HSK / MLD MULTI - LOCK MILLING CHUCK

HSK / MLD 直式筒夾銑床夾頭

(DIN 69893-1)



T W PAT NO. M447277
T W PAT NO. M430337
T W PAT NO. M451185
C N PAT NO. ZL201220749784.4
C H PAT NO. ZL201220749942.6

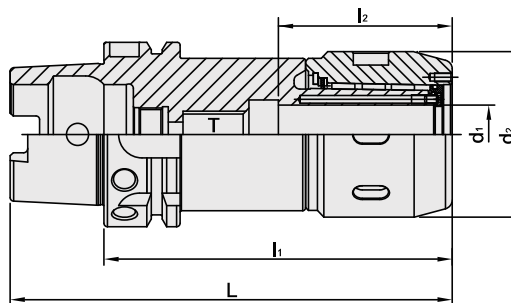

INCHES

MODEL NO.	TYPE	L	l ₁	l ₂	d ₁	d ₂	T	WEIGHT (KGS)
33218G	HSK50A x MLD1/2" - 3.54"	4.528	3.54	1.84	0.5	1.654	-	1.52
33220G	HSK50A x MLD5/8" - 3.94"	4.921	3.94	2.23	0.625	1.889	-	1.62
33222G	HSK50A x MLD3/4" - 4"	4.984	4	2.34	0.75	2.224	-	1.62
33224G	HSK50A x MLD1" - 4.13"	5.118	4.13	2.49	1	2.362	-	1.72
33226G	HSK50A x MLD1-1/4" - 5.12"	6.102	5.12	2.8	1.25	2.795	-	1.70
33228G	HSK63A x MLD1/2" - 3.54"	4.803	3.54	1.84	0.5	1.654	-	1.72
33230G	HSK63A x MLD5/8" - 3.94"	5.197	3.94	2.23	0.625	1.889	-	1.75
33232G	HSK63A x MLD3/4" - 4"	5.26	4	2.34	0.75	2.224	-	1.80
33234G	HSK63A x MLD1" - 4.13"	5.394	4.13	2.49	1	2.362	-	1.65
33236G	HSK63A x MLD1-1/4" - 4.72"	5.984	4.72	2.8	1.25	2.795	-	1.68
33248G	HSK100A x MLD1/2" - 4.53"	6.496	4.53	1.84	0.5	1.654	M12 x 1.75P	1.65
33250G	HSK100A x MLD5/8" - 4.53"	6.496	4.53	2.23	0.625	1.889	M12 x 1.75P	1.65
33252G	HSK100A x MLD3/4" - 4.72"	6.693	4.72	2.34	0.75	2.224	-	1.70
33254G	HSK100A x MLD1" - 4.53"	6.496	4.53	2.49	1	2.362	-	1.72
33256G	HSK100A x MLD1-1/4" - 4.72"	6.693	4.72	2.8	1.25	2.795	-	1.76

Features:

- ▶ Good clamping power. The clamping power of MLD32 type is around 1000 N-m.
- ▶ Runout accuracy of MLD holder body: within 0.005mm.
- ▶ Runout accuracy with collet: within 0.02mm.
- ▶ The tolerance requirement of tool shank diameter is h6.
- ▶ Internal bearing cage helps increase the clamping force.
- ▶ After fastening, the nuts and tool holders contact tight to enhance the cutting rigidity.
- ▶ Coolant options: through the center of holder or cutter. Use sealed caps and SR rings for coolant through cutter.

Product information:

- ▶ The pre-balance reaches G6.3 8,000 rpm. Higher balancing grade and revolution can be done upon request but additional charge is needed.

Standard Accessory: • NUT • SET SCREW

Collet	Sealed Cap	SR Sealed Ring	Coolant Supply Unit	Key	Set Screw	Spanner	Spanner
P.W-32~33	P.W-52	P.W-53	P.W-60	P.W-60	P.W-82	P.W-65~66	P.W-67



HSK / EOC COLLET CHUCK



HSK / EOC 立銑刀夾頭

(DIN 69893-1)
(DIN ISO 10897)



T W PAT NO. M298033
T W PAT NO. M311791
J P PAT NO. 3128766
K R PAT NO. 20-0433603
C N PAT NO. ZL200620132661.0
C H PAT NO. 696550
T R PAT NO. TR 2007 02942 Y
I T PAT NO. N.0000266731

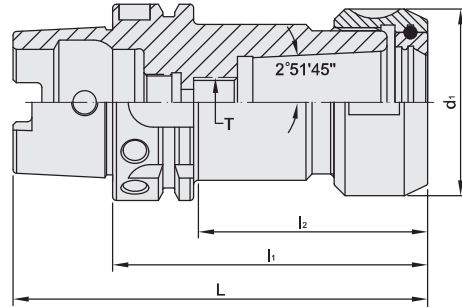

MODEL NO.	TYPE	L	l ₁	l ₂	d ₁	T	SIZE RANGE	WEIGHT (KGS)
31002	HSK50A x EOC16 - 100	125	100	74	43	M12 x 1.75P	2 ~ 16	0.70
31004	HSK50A x EOC16 - 120	145	120	94	43	M12 x 1.75P	2 ~ 16	0.90
31006	HSK50A x EOC25 - 100	125	100	58	60	M16 x 2.0P	3 ~ 25	1.10
31008	HSK50A x EOC25 - 120	145	120	78	60	M16 x 2.0P	3 ~ 25	1.30
31010	HSK50A x EOC25 - 150	175	150	108	60	M16 x 2.0P	3 ~ 25	1.50
31012	HSK50A x EOC32 - 120	145	120	78	72	M20 x 2.0P	4 ~ 32	2.10
31014	HSK50A x EOC32 - 150	175	150	108	72	M20 x 2.0P	4 ~ 32	2.30
31022	HSK63A x EOC16 - 100	132	100	69	43	M12 x 1.75P	2 ~ 16	1.10
31024	HSK63A x EOC16 - 120	152	120	89	43	M12 x 1.75P	2 ~ 16	1.20
31026	HSK63A x EOC25 - 100	132	100	72	60	M16 x 2.0P	3 ~ 25	1.30
31028	HSK63A x EOC25 - 120	152	120	92	60	M16 x 2.0P	3 ~ 25	1.50
31030	HSK63A x EOC25 - 150	182	150	122	60	M16 x 2.0P	3 ~ 25	1.70
31032	HSK63A x EOC32 - 120	152	120	78	72	M20 x 2.0P	4 ~ 32	2.30
31034	HSK63A x EOC32 - 150	182	150	108	72	M20 x 2.0P	4 ~ 32	2.50
31042	HSK100A x EOC16 - 100	150	100	61	43	M12 x 1.75P	2.0 ~ 16	3.40
31044	HSK100A x EOC16 - 120	170	120	81	43	M12 x 1.75P	2.0 ~ 16	3.60
31046	HSK100A x EOC25 - 100	150	100	61	60	-	3.0 ~ 25	3.50
31048	HSK100A x EOC25 - 120	170	120	81	60	M16 x 2.0P	3.0 ~ 25	3.70
31050	HSK100A x EOC25 - 150	200	150	111	60	M16 x 2.0P	3.0 ~ 25	4.10
31052	HSK100A x EOC32 - 130	180	130	91	72	M20 x 2.0P	4.0 ~ 32	4.50
31054	HSK100A x EOC32 - 150	200	150	111	72	M20 x 2.0P	4.0 ~ 32	4.70

Product information:

▶ Balance: G2.5 25,000 rpm. Higher balancing grade and revolution can be done upon request but additional charge is needed.

Standard Accessory: • NUT

Collet	Nut	Coolant Supply Unit	Key	Preset Screw	Spanner
P.W-35	P.W-51	P.W-60	P.W-60	P.W-82	P.W-62~66



HSK / SLN SIDE LOCK END MILL HOLDER

HSK / SLN 側固式立銑刀柄

(DIN 69893-1)

(DIN 1835-B)

(DIN 69882-4)

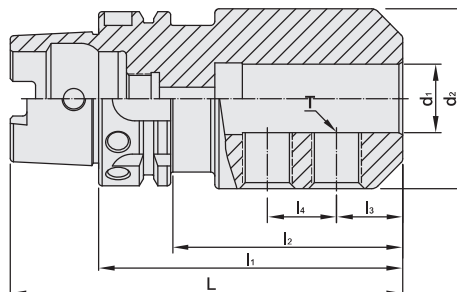

MODEL NO.	TYPE	L	l ₁	l ₂	l ₃	l ₄	d ₁	d ₂	T	WEIGHT (KGS)
32802	HSK50A x SLN6 - 65	90	65	34	18	-	6	25	M6 x 1.0P	0.70
32804	HSK50A x SLN8 - 65	90	65	36	18	-	8	28	M8 x 1.25P	0.80
32806	HSK50A x SLN10 - 65	90	65	36.5	20	-	10	35	M10 x 1.5P	0.80
32808	HSK50A x SLN12 - 80	105	80	53.5	22.5	-	12	42	M12 x 1.75P	1.20
32810	HSK50A x SLN14 - 80	105	80	53.5	22.5	-	14	44	M12 x 1.75P	1.30
32812	HSK50A x SLN16 - 80	105	80	53.5	24	-	16	48	M14 x 2.0P	1.30
32814	HSK50A x SLN18 - 80	105	80	53.5	24	-	18	50	M14 x 2.0P	1.40
32816	HSK50A x SLN20 - 80	105	80	53	25	-	20	52	M16 x 2.0P	1.50
32822	HSK63A x SLN6 - 65	97	65	36	18	-	6	25	M6 x 1.0P	0.90
32824	HSK63A x SLN8 - 65	97	65	36	18	-	8	28	M8 x 1.25P	1.00
32826	HSK63A x SLN10 - 65	97	65	36	20	-	10	35	M10 x 1.5P	1.00
32828	HSK63A x SLN12 - 80	112	80	49	22.5	-	12	42	M12 x 1.75P	1.70
32830	HSK63A x SLN14 - 80	112	80	51	22.5	-	14	44	M12 x 1.75P	1.70
32832	HSK63A x SLN16 - 80	112	80	51.5	24	-	16	48	M14 x 2.0P	1.70
32834	HSK63A x SLN18 - 80	112	80	52.5	24	-	18	50	M14 x 2.0P	1.80
32836	HSK63A x SLN20 - 80	112	80	53.5	25	-	20	52	M16 x 2.0P	1.80
32838	HSK63A x SLN25 - 110	142	110	83.2	24	25	25	65	M18 x 2.0P	2.50
32840	HSK63A x SLN32 - 110	142	110	83.2	24	28	32	72	M20 x 2.0P	2.70
32862	HSK100A x SLN6 - 80	130	80	41	18	-	6	25	M6 x 1.0P	3.00
32864	HSK100A x SLN8 - 80	130	80	41	18	-	8	28	M8 x 1.25P	3.20
32866	HSK100A x SLN10 - 80	130	80	46	20	-	10	35	M10 x 1.5P	3.40
32868	HSK100A x SLN12 - 80	130	80	46	22.5	-	12	42	M12 x 1.75P	3.40
32870	HSK100A x SLN14 - 80	130	80	46	22.5	-	14	44	M12 x 1.75P	3.50
32872	HSK100A x SLN16 - 100	150	100	66	24	-	16	48	M14 x 2.0P	3.80
32874	HSK100A x SLN18 - 100	150	100	66	24	-	18	50	M16 x 2.0P	3.80
32876	HSK100A x SLN20 - 100	150	100	61	25	-	20	52	M16 x 2.0P	3.90
32878	HSK100A x SLN25 - 100	150	100	66	24	25	25	65	M18 x 2.0P	4.00
32880	HSK100A x SLN32 - 100	150	100	66	24	28	32	72	M20 x 2.0P	4.10
32882	HSK100A x SLN40 - 120	170	120	89	30	32	40	90	M20 x 2.0P	4.40

Product information:

- ▶ The tolerance requirement of tool shank diameter is h6.
- ▶ The pre-balance reaches G6.3 8,000 rpm. Higher balancing grade and revolution can be done upon request but additional charge is needed.

Standard Accessory: • LOCK SCREW

Coolant Supply Unit	Key	Lock Screw
		
P.W-60	P.W-60	P.W-84



HSK / SLN SIDE LOCK END MILL HOLDER

HSK / SLN 側固式立銑刀柄

(DIN 69893-1)

(DIN 1835-B)

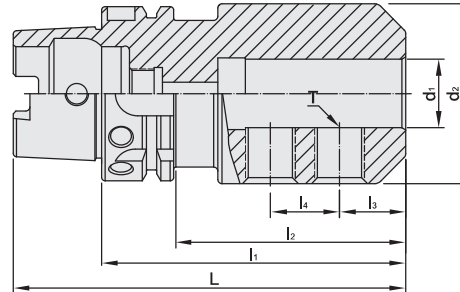

INCHES

MODEL NO.	TYPE	L	l ₁	l ₂	l ₃	l ₄	d ₁	d ₂	T	WEIGHT (KGS)
32922	HSK40A x SLN1/4" - 2.5"	3.287	2.5	1.516	0.63	-	0.25	0.78	1/4 - 28	0.31
32926	HSK40A x SLN3/8" - 2.5"	3.287	2.5	1.594	0.75	-	0.375	1	3/8 - 24	0.42
32928	HSK40A x SLN1/2" - 2.75"	3.537	2.75	1.923	0.875	-	0.5	1.38	7/16 - 20	0.57
32930	HSK40A x SLN5/8" - 3"	3.787	3	2.181	0.937	-	0.625	1.63	1/2 - 20	0.69
32948	HSK63A x SLN1/4" - 3"	4.26	3	1.78	0.63	-	0.25	0.78	1/4 - 28	0.76
32952	HSK63A x SLN3/8" - 3"	4.26	3	1.78	0.75	-	0.375	1	3/8 - 24	0.88
32954	HSK63A x SLN1/2" - 3"	4.26	3	1.78	0.875	-	0.5	1.38	7/16 - 20	1.13
32956	HSK63A x SLN5/8" - 3.75"	5	3.75	2.53	0.937	-	0.625	1.63	1/2 - 20	1.26
32958	HSK63A x SLN3/4" - 3.75"	5	3.75	2.648	1	-	0.75	1.75	5/8 - 18	1.33
32962	HSK63A x SLN1" - 3.75"	5	3.75	2.687	1.125	1	1	2	3/4 - 16	2.30
32964	HSK63A x SLN1-1/4" - 4.25"	5.51	4.25	3.187	1.125	1	1.25	2.5	3/4 - 16	2.52
32978	HSK100A x SLN1/4" - 3"	4.97	3	1.465	0.63	-	0.25	0.78	1/4 - 28	2.16
32982	HSK100A x SLN3/8" - 3"	4.97	3	1.661	0.75	-	0.375	1	3/8 - 24	2.31
32984	HSK100A x SLN1/2" - 3.25"	5.219	3.25	1.911	0.875	-	0.5	1.38	7/16 - 20	2.45
32986	HSK100A x SLN5/8" - 3.75"	5.719	3.75	2.411	0.937	-	0.625	1.63	1/2 - 20	2.84
32988	HSK100A x SLN3/4" - 3.75"	5.719	3.75	2.411	1	-	0.75	1.75	5/8 - 18	2.95
32992	HSK100A x SLN1" - 4.25"	6.219	4.25	2.911	1.125	1	1	2	3/4 - 16	3.46
32994	HSK100A x SLN1-1/4" - 4.25"	6.219	4.25	2.911	1.125	1	1.25	2.5	3/4 - 16	3.73
32996	HSK100A x SLN1-1/2" - 4.5"	6.469	4.5	3.161	1.125	1	1.5	2.5	3/4 - 16	5.51
32998	HSK100A x SLN2" - 5.5"	7.469	5.5	4.319	1.41	1.5	2	3.75	1 - 14	6.37

Product information:

- ▶ Internal hole tolerance: H5 (DIN-1835-B standard).
- ▶ The tolerance requirement of tool shank diameter is h6.
- ▶ The pre-balance reaches G6.3 8,000 rpm. Higher balancing grade and revolution can be done upon request but additional charge is needed.

Standard Accessory: • LOCK SCREW

Coolant Supply Unit	Key	Lock Screw
		
P.W-60	P.W-60	P.W-84



HSK / SLN SIDE LOCK END MILL HOLDER

JIS TYPE

HSK / SLN 側固式立銑刀柄 [JIS 型]

[DIN 69893-1]

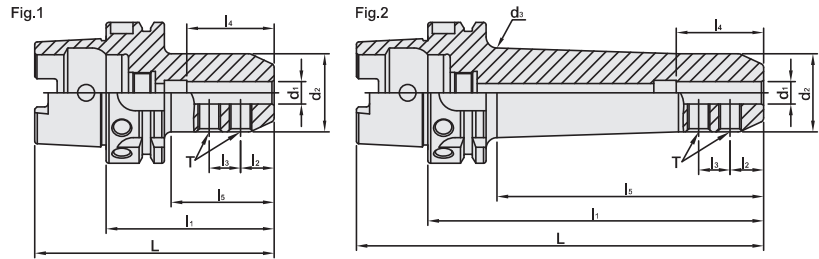

MODEL NO.	TYPE	L	l ₁	l ₂	l ₃	l ₄	l ₅	d ₁	d ₂	d ₃	T	Fig.	WEIGHT (KGS)
33826	HSK63A x SLN10 - 75JIS	107	75	15	14	39	46	10	35	-	M6 x 1.0P	1	0.94
33826 - 150	HSK63A x SLN10 - 150JIS	182	150	15	14	39	119.1	10	35	40	M6 x 1.0P	2	1.56
33828	HSK63A x SLN12 - 80JIS	112	80	20	16	44	51	12	42	-	M10 x 1.5P	1	1.12
33828 - 150	HSK63A x SLN12 - 150JIS	182	150	20	16	44	121.1	12	42	47	M10 x 1.5P	2	1.94
33832	HSK63A x SLN16 - 90JIS	122	90	22	18	47	62	16	48	-	M10 x 1.5P	1	1.38
33832 - 160	HSK63A x SLN16 - 150JIS	182	150	22	18	47	123	16	48	53	M10 x 1.5P	2	2.31
33836	HSK63A x SLN20 - 90JIS	122	90	25	20	55	62.5	20	50	-	M12 x 1.75P	1	1.41
33836 - 150	HSK63A x SLN20 - 150JIS	182	150	25	20	55	123	20	50	53	M12 x 1.75P	2	2.35
33838	HSK63A x SLN25 - 90JIS	122	90	24	25	58	62.5	25	52	-	M12 x 1.75P	1	1.31
33838 - 150	HSK63A x SLN25 - 150JIS	182	150	24	25	58	123	25	52	53	M12 x 1.75P	2	2.25
33840	HSK63A x SLN32 - 105JIS	137	105	24	28	63	79	32	60	-	M16 x 2.0P	1	1.73

Product information:

- ▶ Internal hole tolerance: H5 (DIN-1835-B standard).
- ▶ The tolerance requirement of tool shank diameter is h6.
- ▶ The pre-balance reaches G6.3 8,000 rpm. Higher balancing grade and revolution can be done upon request but additional charge is needed.

Standard Accessory: • LOCK SCREW

Coolant Supply Unit	Key	Lock Screw
 P.W-60	 P.W-60	 P.W-84



HSK / SLNB SIDE LOCK END MILL HOLDER

HSK / SLNB 側固式立銑刀柄

(DIN 69893-1)

(DIN 1835-E)

(DIN 69882-5)

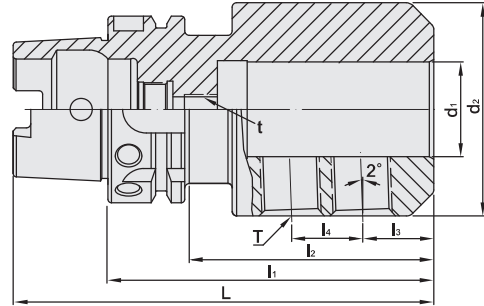

MODEL NO.	TYPE	L	l ₁	l ₂	l ₃	l ₄	d ₁	d ₂	t	T	WEIGHT (KGS)
33102	HSK50A x SLNB6 - 80	105	80	49	18	-	6	25	M5	M6 x 1.0P	0.80
33104	HSK50A x SLNB8 - 80	105	80	49	18	-	8	28	M6	M8 x 1.25P	0.90
33106	HSK50A x SLNB10 - 80	105	80	51	20	-	10	35	M8	M10 x 1.5P	0.90
33108	HSK50A x SLNB12 - 90	115	90	64	22.5	-	12	42	M10	M12 x 1.75P	1.30
33110	HSK50A x SLNB14 - 90	115	90	63.2	22.5	-	14	44	M10	M12 x 1.75P	1.40
33112	HSK50A x SLNB16 - 90	115	90	63.2	24	-	16	48	M12	M14 x 2.0P	1.40
33114	HSK50A x SLNB18 - 90	115	90	63.2	24	-	18	50	M12	M14 x 2.0P	1.60
33116	HSK50A x SLNB20 - 100	125	100	73	25	-	20	52	M16	M16 x 2.0P	1.70
33132	HSK63A x SLNB6 - 80	112	80	49	18	-	6	25	M5	M6 x 1.0P	1.00
33134	HSK63A x SLNB8 - 80	112	80	49	18	-	8	28	M6	M8 x 1.25P	1.10
33136	HSK63A x SLNB10 - 80	112	80	51	20	-	10	35	M8	M10 x 1.5P	1.10
33138	HSK63A x SLNB12 - 90	122	90	64	22.5	-	12	42	M10	M12 x 1.75P	2.00
33140	HSK63A x SLNB14 - 90	122	90	61	22.5	-	14	44	M10	M12 x 1.75P	2.00
33142	HSK63A x SLNB16 - 100	132	100	72	24	-	16	48	M12	M14 x 2.0P	2.00
33144	HSK63A x SLNB18 - 100	132	100	72.5	24	-	18	50	M12	M14 x 2.0P	2.10
33146	HSK63A x SLNB20 - 100	132	100	72.5	25	-	20	52	M16	M16 x 2.0P	2.10
33148	HSK63A x SLNB25 - 110	142	110	83.2	24	25	25	65	M20	M18 x 2.0P	2.60
33150	HSK63A x SLNB32 - 110	142	110	82.5	24	24	32	72	-	M20 x 2.0P	2.80
33162	HSK100A x SLNB6 - 90	140	90	51	18	-	6	25	M5	M6 x 1.0P	3.40
33164	HSK100A x SLNB8 - 90	140	90	51	18	-	8	28	M6	M8 x 1.25P	3.50
33166	HSK100A x SLNB10 - 90	140	90	51	20	-	10	35	M8	M10 x 1.5P	3.80
33168	HSK100A x SLNB12 - 100	150	100	61	22.5	-	12	42	M10	M12 x 1.75P	3.80
33170	HSK100A x SLNB14 - 100	150	100	61	22.5	-	14	44	M10	M12 x 1.75P	4.00
33172	HSK100A x SLNB16 - 100	150	100	66	24	-	16	48	M12	M14 x 2.0P	4.00
33174	HSK100A x SLNB18 - 100	150	100	61	24	-	18	50	M12	M14 x 2.0P	4.00
33176	HSK100A x SLNB20 - 110	160	110	71	25	-	20	52	M16	M16 x 2.0P	4.20
33178	HSK100A x SLNB25 - 120	170	120	86	24	22	25	65	M20	M18 x 2.0P	4.40
33180	HSK100A x SLNB32 - 120	170	120	86	24	24	32	72	M20	M20 x 2.0P	4.50
33182	HSK100A x SLNB40 - 120	170	120	89	30	32	40	90	M20	M20 x 2.0P	5.00

Product information:

- ▶ Internal hole tolerance: H5 (DIN-1835-B standard).
- ▶ The tolerance requirement of tool shank diameter is h6.
- ▶ The pre-balance reaches G6.3 8,000 rpm. Higher balancing grade and revolution can be done upon request but additional charge is needed.

Standard Accessory: • LOCK SCREW

Coolant Supply Unit	Key	Lock Screw
		
P.W-60	P.W-60	P.W-84

HSK FACE MILL ARBOR

FMB TYPE

HSK 平面銑刀柄

[DIN 69893-1]

HSK - A

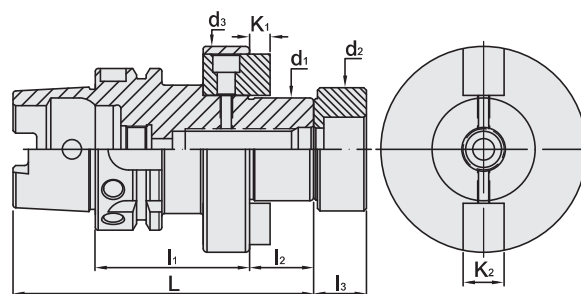

MODEL NO.	TYPE	L	l ₁	l ₂	l ₃	d ₁	d ₂	d ₃	K ₁	K ₂	WEIGHT (KGS)
32392	HSK40A x FMB16 - 50	87	50	17	-	16	-	40	5	8	0.70
32394	HSK40A x FMB22 - 60	99	60	19	14	22	26	52	4.8	10	0.80
32396	HSK40A x FMB27 - 60	101	60	21	16	27	31.5	60	5.8	12	1.00
32398	HSK40A x FMB32 - 60	104	60	24	16	32	41	78	6.8	14	1.10
32402	HSK50A x FMB16 - 50	92	50	17	-	16	-	40	5	8	1.10
32404	HSK50A x FMB22 - 60	104	60	19	14	22	26	48	4.8	10	1.00
32406	HSK50A x FMB27 - 60	106	60	21	16	27	31.5	60	5.8	12	1.30
32408	HSK50A x FMB32 - 60	109	60	24	16	32	41	78	6.8	14	1.50
32412	HSK63A x FMB16 - 50	99	50	17	-	16	-	40	5	8	1.20
32414	HSK63A x FMB22 - 50	101	50	19	14	22	26	50	4.8	10	1.30
32416	HSK63A x FMB27 - 60	113	60	21	16	27	31.5	53	5.8	12	1.50
32418	HSK63A x FMB32 - 60	116	60	24	16	32	41	78	6.8	14	1.60
32420	HSK63A x FMB40 - 60	117	60	25	20.5	40	48	80	8.3	16	2.10
32442	HSK100A x FMB22 - 50	119	50	19	14	22	26	48	4.8	10	2.70
32444	HSK100A x FMB27 - 50	121	50	21	16	27	31.5	60	5.8	12	2.90
32446	HSK100A x FMB32 - 50	124	50	24	16	32	41	78	6.8	14	3.00
32448	HSK100A x FMB40 - 60	135	60	25	20.5	40	48	80	8.3	16	4.00
32450	HSK100A x FMB50 - 70	150	70	30	24	50	68	120	9.7	19	5.10
32452	HSK100A x FMB60 - 70	160	70	40	-	60	-	129	12.5	25.4	5.50

Product information:

- ▶ d1 tolerance: h6.
- ▶ The pre-balance reaches G6.3 3,000 rpm. Higher balancing grade and revolution can be done upon request but additional charge is needed.

Coolant Supply Unit	Key	Screw
 P.W-60	 P.W-60	 P.W-84



HSK FACE MILL ARBOR FMC TYPE

HSK 平面铣刀柄

[DIN 69893-1]

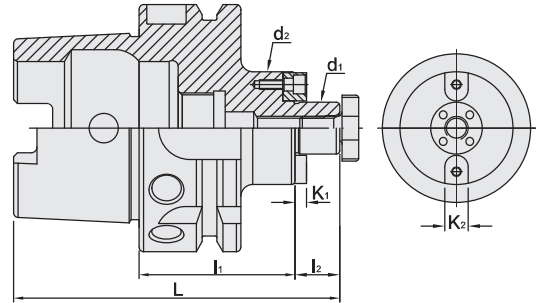





MODEL NO.	TYPE	L	l ₁	l ₂	d ₁	d ₂	K ₁	K ₂	WEIGHT (KGS)
32530	HSK50A x FMC16 - 60	102	60	17	16	40	5	8	1.30
32532	HSK50A x FMC22 - 60	104	60	19	22	50	4.8	10	1.40
32534	HSK50A x FMC27 - 60	106	60	21	27	60	5.8	12	1.30
32540	HSK63A x FMC16 - 50	99	50	17	16	40	5	8	1.20
32542	HSK63A x FMC22 - 50	101	50	19	22	50	4.8	10	1.30
32544	HSK63A x FMC27 - 60	113	60	21	27	60	5.8	12	1.70
32546	HSK63A x FMC32 - 60	116	60	24	32	78	6.8	14	1.60
32560	HSK100A x FMC16 - 50	117	50	17	16	40	5	8	2.80
32562	HSK100A x FMC22 - 50	119	50	19	22	50	4.8	10	2.90
32564	HSK100A x FMC27 - 50	121	50	21	27	60	5.8	12	2.90
32566	HSK100A x FMC32 - 60	134	60	24	32	78	6.8	14	3.30
32568	HSK100A x FMC40 - 70	147	70	27	40	89	8.3	16	4.30



Product information:

- ▶ d1 tolerance: h6.
- ▶ The pre-balance reaches G6.3 3,000 rpm. Higher balancing grade and revolution can be done upon request but additional charge is needed.

Standard Accessory: • NUT • SPANNER

Nut	Coolant Supply Unit	Key	Spanner
			
P.W-61	P.W-60	P.W-60	P.W-61

HSK / COMBI SHELL END MILL ARBOR

HSK 聯結式銑刀柄

(DIN 69893-1)
(DIN 69228-2)

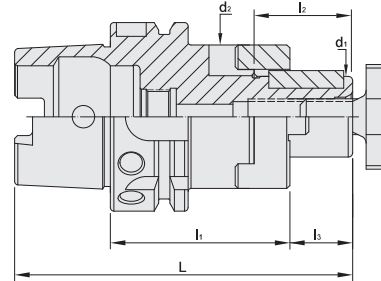

MODEL NO.	TYPE	L	l ₁	l ₂	l ₃	d ₁	d ₂	WEIGHT (KGS)
32662	HSK32A x CSR16 - 55	88	55	27	17	16	32	0.50
32664	HSK32A x CSR22 - 55	90	55	31	19	22	40	0.50
32666	HSK32A x CSR27 - 65	102	65	33	21	27	48	0.60
32668	HSK40A x CSR16 - 50	87	50	27	17	16	32	0.50
32670	HSK40A x CSR22 - 50	89	50	31	19	22	40	0.60
32672	HSK40A x CSR27 - 65	106	65	33	21	27	48	0.70
32602	HSK50A x CSR16 - 50	92	50	27	17	16	32	0.77
32604	HSK50A x CSR22 - 50	94	50	31	19	22	40	0.88
32606	HSK50A x CSR27 - 65	111	65	33	21	27	48	1.10
32608	HSK50A x CSR32 - 65	114	65	38	24	32	50	1.40
32612	HSK63A x CSR16 - 60	109	60	27	17	16	32	0.97
32614	HSK63A x CSR22 - 60	111	60	31	19	22	40	1.08
32616	HSK63A x CSR27 - 60	113	60	33	21	27	48	1.30
32618	HSK63A x CSR32 - 60	116	60	38	24	32	52	1.60
32620	HSK63A x CSR40 - 70	129	70	41	27	40	70	2.05
32640	HSK100A x CSR16 - 60	127	60	27	17	16	32	2.47
32642	HSK100A x CSR22 - 60	129	60	31	19	22	40	2.68
32644	HSK100A x CSR27 - 60	131	60	33	21	27	48	2.90
32646	HSK100A x CSR32 - 60	134	60	38	24	32	58	3.20
32648	HSK100A x CSR40 - 70	147	70	41	27	40	70	3.65
32650	HSK100A x CSR50 - 80	160	80	46	30	50	90	4.10

Product information:

- ▶ d1 tolerance: h6.
- ▶ The pre-balance reaches G6.3 8,000 rpm. Higher balancing grade and revolution can be done upon request but additional charge is needed.

Standard Accessory: • KEY • REMOVABLE RING • NUT • SPANNER

Key	Removable Ring	Nut	Coolant Supply Unit	Key	Spanner
P.W-61	P.W-61	P.W-61	P.W-60	P.W-60	P.W-61



HSK / SPH DRILL CHUCK ADAPTER

HSK / SPH 直結式鑽夾頭

[DIN 69893-1]

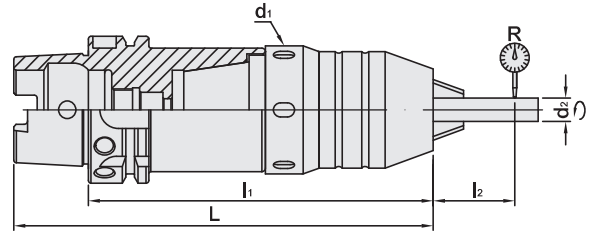

MODEL NO.	TYPE	L	l ₁	l ₂	d ₁	d ₂	R	WEIGHT (KGS)
35004	HSK40A x SPH8 - 135	155	135	55	42	6	0.04	1.40
35008	HSK40A x SPH13 - 125	145	125	75	54	8	0.04	1.60
35020	HSK63A x SPH8 - 130	162	130	55	42	6	0.04	1.40
35024	HSK63A x SPH13 - 150	182	150	75	54	8	0.04	1.60



Features:

- ▶ The adapter has a taper design to assemble with drill chuck and then lock with a screw, ensuring to have better stability and drill chuck would not fall off.
- ▶ Used for drilling & tapping.
- ▶ The clamping capacity of SPH8 is 1~8mm.
- ▶ The clamping capacity of SPH13 is 1~13mm.
- ▶ The clamping capacity of SPH16 is 3~16mm.

Product information:

- ▶ The pre-balance reaches G6.3 8,000 rpm. Higher balancing grade and revolution can be done upon request but additional charge is needed.

Standard Accessory: • SPANNER

Coolant Supply Unit	Key
 P.W-60	 P.W-60



HSK / SPU DRILL CHUCK ADAPTER

HSK / SPU 直結式鑽夾頭

(DIN 69893-1)

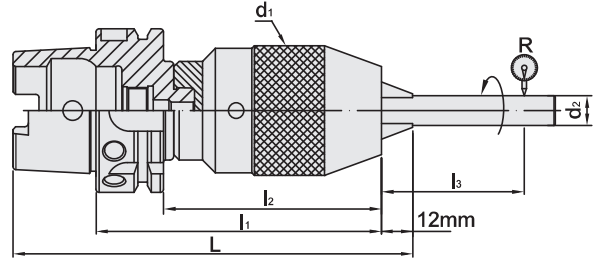

MODEL NO.	TYPE	L	l ₁	l ₂	l ₃	d ₁	d ₂	R	WEIGHT (KGS)
34903	HSK50A x SPU13 - 150	187	150	124	55	50	5	0.04	1.40
34905	HSK63A x SPU13 - 150	194	150	124	55	50	10	0.04	2.10
34907	HSK100A x SPU13 - 155	217	155	126	75	50	13	0.04	3.10

Features:

- ▶ The adapter has a taper design to assemble with drill chuck and then lock with a screw, ensuring to have better stability and drill chuck would not fall off.
- ▶ Used for drilling.
- ▶ The clamping capacity of SPU8 is 1~8mm.
- ▶ The clamping capacity of SPU13 is 1~13mm.
- ▶ The clamping capacity of SPU16 is 3~16mm.

Product information:

- ▶ The pre-balance reaches G6.3 8,000 rpm. Higher balancing grade and revolution can be done upon request but additional charge is needed.

Standard Accessory: • SPANNER

Coolant Supply Unit	Key	Spanner
 P.W-60	 P.W-60	 P.W-66



HSK / SOM SCREWED END MILL HOLDER

HSK / SOM 螺紋鎖固式刀桿

(DIN 69893-1)

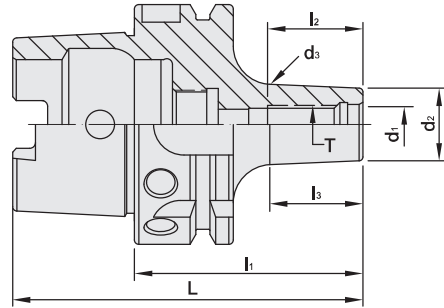

MODEL NO.	TYPE	L	l ₁	l ₂	l ₃	d ₁	d ₂	d ₃	T	WEIGHT (KGS)
39230	HSK50A x SOM6 - 60	85	60	25	24	6.5	13	15	M6 x 1.0P	0.70
39232	HSK50A x SOM8 - 60	85	60	25	24	8.5	15	17	M8 x 1.25P	0.70
39234	HSK50A x SOM10 - 60	85	60	25	24	10.5	19	21	M10 x 1.5P	0.80
39236	HSK50A x SOM12 - 70	95	70	31	36	12.5	21	24	M12 x 1.75P	0.80
39238	HSK50A x SOM16 - 80	105	80	31	49	17	25	29	M16 x 2.0P	0.80
39250	HSK63A x SOM6 - 60	92	60	25	24	6.5	13	15	M6 x 1.0P	1.00
39252	HSK63A x SOM8 - 60	92	60	25	24	8.5	15	17	M8 x 1.25P	1.00
39254	HSK63A x SOM10 - 60	92	60	25	24	10.5	19	21	M10 x 1.5P	1.10
39256	HSK63A x SOM12 - 70	102	70	31	34	12.5	21	23	M12 x 1.75P	1.10
39258	HSK63A x SOM16 - 80	112	80	30	49	17	25	29	M16 x 2.0P	1.10
39270	HSK100A x SOM6 - 90	140	90	25	51	6.5	13	17	M6 x 1.0P	2.18
39272	HSK100A x SOM8 - 90	140	90	25	51	8.5	15	19	M8 x 1.25P	2.19
39274	HSK100A x SOM10 - 95	145	95	25	56	10.5	19	23	M10 x 1.5P	2.26
39276	HSK100A x SOM12 - 90	140	90	31	51	12.5	21	25	M12 x 1.75P	2.31
39278	HSK100A x SOM16 - 100	150	100	31	61	17	25	30	M16 x 2.0P	2.55

Product information:

► Balance: G2.5 25,000 rpm. Higher balancing grade and revolution can be done upon request but additional charge is needed.

[STR Cutting Tool](#) [RG Cutting Tool](#) [DM Cutting Tool](#) [Extension Spacer](#)



HSK MORSE TAPER ADAPTER

TANG TYPE

HSK 斜柄鑽頭套筒

[DIN 69893-1]

HSK - A

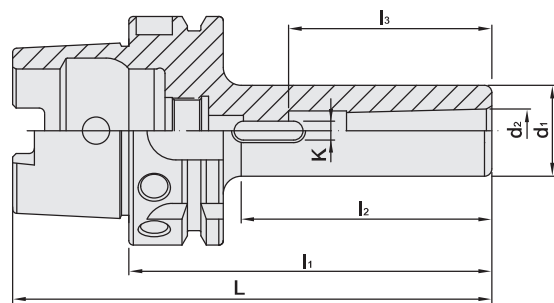

MODEL NO.	TYPE	L	l ₁	l ₂	l ₃	d ₁	d ₂	K	WEIGHT (KGS)
35102	HSK50A x MTA1 - 100	125	100	69	56	25	12.065	5.2	1.50
35104	HSK50A x MTA2 - 120	145	120	89	67	32	17.78	6.3	1.80
35106	HSK50A x MTA3 - 140	165	140	113	84	40	23.825	7.9	1.90
35112	HSK63A x MTA1 - 100	132	100	69	56	25	12.065	5.2	1.90
35114	HSK63A x MTA2 - 120	152	120	89	67	32	17.78	6.3	2.00
35116	HSK63A x MTA3 - 140	172	140	109	84	40	23.825	7.9	2.20
35118	HSK63A x MTA4 - 160	192	160	132	107	48	31.267	11.9	2.50
35122	HSK100A x MTA1 - 110	160	110	71	56	25	12.065	5.2	3.40
35124	HSK100A x MTA2 - 120	170	120	81	67	32	17.78	6.3	3.80
35126	HSK100A x MTA3 - 150	200	150	111	84	40	23.825	7.9	4.00
35128	HSK100A x MTA4 - 170	220	170	131	107	48	31.267	11.9	4.60
35130	HSK100A x MTA5 - 200	250	200	166	135	63	44.399	15.9	5.20

Features:

- ▶ Roundness: 0.005mm.
- ▶ MTA=TANG TYPE=DIN 228-B.

Coolant Supply Unit

Key



P.W-60



P.W-60





HSK / PSC ADAPTER

HSK / PSC 套筒

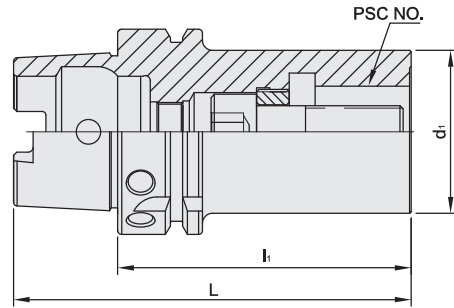
[DIN 69893-1]



MODEL NO.	TYPE	NO.	L	li	d ₁	T	TORQUE		WEIGHT (KGS)
							MIN.	MAX.	
73.501.32.075	HSK63A x PSC32 - 75	PSC32	107	75	32	M12 x 1.5P	45 Nm	55 Nm	0.92
73.501.40.080	HSK63A x PSC40 - 80	PSC40	112	80	40	M14 x 1.5P	45 Nm	55 Nm	1.06
73.501.50.090	HSK63A x PSC50 - 90	PSC50	122	90	50	M16 x 1.5P	45 Nm	55 Nm	1.39
75.501.32.080	HSK100A x PSC32 - 80	PSC32	130	80	32	M12 x 1.5P	45 Nm	55 Nm	2.25
75.501.40.090	HSK100A x PSC40 - 90	PSC40	140	90	40	M14 x 1.5P	45 Nm	55 Nm	2.43
75.501.50.100	HSK100A x PSC50 - 100	PSC50	150	100	50	M16 x 1.5P	45 Nm	55 Nm	2.80
75.501.63.110	HSK100A x PSC63 - 110	PSC63	160	110	63	M20 x 2.0P	65 Nm	75 Nm	3.41
75.501.63.150	HSK100A x PSC63 - 150	PSC63	200	150	63	M20 x 2.0P	65 Nm	75 Nm	4.18
75.501.63.200	HSK100A x PSC63 - 200	PSC63	250	200	63	M20 x 2.0P	65 Nm	75 Nm	5.14
75.501.63.250	HSK100A x PSC63 - 250	PSC63	300	250	63	M20 x 2.0P	65 Nm	75 Nm	6.10
75.501.63.300	HSK100A x PSC63 - 300	PSC63	350	300	63	M20 x 2.0P	65 Nm	75 Nm	7.07
75.501.80.120	HSK100A x PSC80 - 120	PSC80	170	120	80	M20 x 2.0P	65 Nm	75 Nm	4.93

Coolant Supply Unit	Key
	
P.W-60	P.W-60

HSK BLANK

HSK 素材

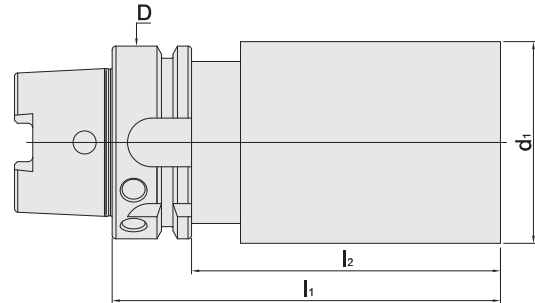

METRIC

MODEL NO.	TYPE	D	d ₁	l ₁	l ₂	WEIGHT (KGS)
70.001.67.043	HSK32A x ϕ 67 - 43.8	32	67	43.8	23.8	0.51
73.001.62.300	HSK63A x ϕ 62 - 3"	63	62	76.2	50.2	1.80
73.001.62.400	HSK63A x ϕ 62 - 4"	63	62	101.6	75.6	2.39
73.001.62.500	HSK63A x ϕ 62 - 5"	63	62	127	101	2.98
75.001.75.200	HSK100A x ϕ 75 - 200	100	75	200	171	7.87
75.001.97.250	HSK100A x ϕ 97 - 250	100	97	250	221	14.47
73T.001.62.150	HSKT63 x ϕ 62 - 150	63	62	150	124	3.51
73T.001.62.200	HSKT63 x ϕ 62 - 200	63	62	200	174	4.67
73T.001.62.250	HSKT63 x ϕ 62 - 250	63	62	250	224	5.84
73T.001.80.150	HSKT63 x ϕ 80 - 150	63	80	150	124	5.18
73T.001.80.200	HSKT63 x ϕ 80 - 200	63	80	200	174	7.12
73T.001.80.250	HSKT63 x ϕ 80 - 250	63	80	250	224	9.05
85.001.32.100	HSK32C x ϕ 32 - 100	32	32	100	-	0.79
88.001.115.150	HSK63C x ϕ 115 - 150	63	115	150	137.5	11.48

INCHES

73.001.92.600	HSK63A x ϕ 2.5" - 6"	63	2.5	6	4.98	3.69
75.001.77.200	HSK100A x ϕ 1.5" - 2"	100	1.5	2	0.86	2.25
75.001.77.812	HSK100A x ϕ 1.5" - 8.12"	100	1.5	8.12	6.98	3.61
75.001.77.110	HSK100A x ϕ 1.5" - 11"	100	1.5	11	9.86	4.25
75.001.99.100	HSK100A x ϕ 4" - 10"	100	4	10	8.86	15.85

REFERENCE DETAILS

DIN 69893 - E

- ▶ Shank body standard: **DIN 69893 - 5**
- ▶ Taper tolerance < **AT3**
- ▶ Hardness > **HRC 56°**
- ▶ Surface roughness: Ra < **0.25 μm**
- ▶ Roundness < **0.8 μm**
- ▶ Carbon depth > **0.8mm**
- ▶ The shank has pre-balance at G6.3, and can provide precision balance at G2.5. It can be ordered by request.

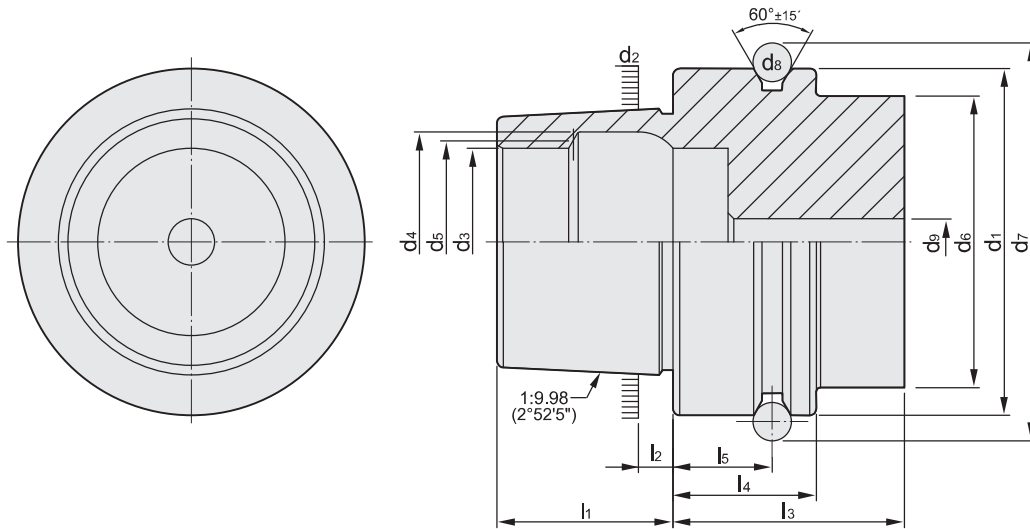

FROM E

HSK	d ₁ h ₁₀	d ₂	d ₃ H ₁₀	d ₄ H ₁₁	d ₅	d ₆ max.	d ₇ 0 -0.1
25	25	19.006	14	16.4	15	20	28.5
32	32	24.007	17	20.5	19	26	37
40	40	30.007	21	25.5	23	34	45
50	50	38.009	26	32	29	42	59.3
63	63	48.010	34	40	37	53	72.3
80	80	60.012	42	50	46	68	88.8
100	100	75.013	53	63	58	88	109.75
125	125	95.016	67	80	73	111	134.75
HSK	d ₈	d ₉ max.	l ₁ 0 -0.2	l ₂	l ₃ min.	l ₄ 0 -0.1	l ₅ ±0.1
25	3	3	13	2.5	20	10	4.5
32	4	4.2	16	3.2	35	20	16
40	4	5	20	4	35	20	16
50	7	6.8	25	5	42	26	18
63	7	8.4	32	6.3	42	26	18
80	7	10.2	40	8	42	26	18
100	7	12	50	10	45	29	20
125	7	14	63	12.5	45	29	20



HSK / PTER COLLET CHUCK

5 μ m

HSK / PTER 立銑刀夾頭

[DIN 69893-5]



T W PAT NO. M298033
 T W PAT NO. M311791
 J P PAT NO. 3128766
 J P PAT NO. 33200356
 K R PAT NO. 20-0433603
 C N PAT NO. ZL200620132661.0
 C H PAT NO. 696550
 T R PAT NO. TR 2007 02942 Y
 I T PAT NO. N.0000266731

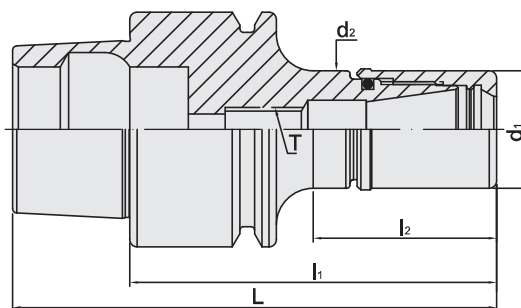





MODEL NO.	TYPE	L	l ₁	l ₂	d ₁	d ₂	T	SIZE RANGE	WEIGHT (KGS)
35802 - E	HSK25E x PTER8 - 35	48	35	23	12	12	-	3 ~ 5	0.06
35804 - E	HSK25E x PTER11 - 35	48	35	24	16	16	-	3 ~ 7	0.07
35806 - E	HSK25E x PTER16 - 48	61	48	28	22	22	-	3 ~ 10	0.10
35812 - E	HSK32E x PTER8 - 50	66	50	25	12	12	-	3 ~ 5	0.15
35814 - E	HSK32E x PTER11 - 50	66	50	25	16	16	M6 x 1.0P	3 ~ 7	0.16
35816 - 55 - E	HSK32E x PTER16 - 55	71	55	33	22	22	-	3 ~ 10	0.18
35816 - 60 - E	HSK32E x PTER16 - 60	76	60	38	22	22	-	3 ~ 10	0.19
35822 - E	HSK40E x PTER8 - 40	60	40	17	12	12	-	3 ~ 5	0.22
35824 - E	HSK40E x PTER11 - 40	60	40	19.5	16	16	-	3 ~ 7	0.22
35826 - 55 - E	HSK40E x PTER16 - 55	75	55	34	22	22	-	3 ~ 10	0.26
35828 - E	HSK40E x PTER20 - 55	75	55	34	28	28	-	3 ~ 13	0.30
35830 - E	HSK40E x PTER25 - 65	85	65	44	35	34	-	3 ~ 16	0.44

Product information:

- ▶ Balance: G2.5 25,000 rpm. Higher balancing grade and revolution can be done upon request but additional charge is needed.
- ▶ Use PN-U 5 μ m collet.

Standard Accessory: • NUT

Collet	Nut	Preset Screw	Spanner
			
P.W-4	P.W-41	P.W-82	P.W-62~67



HSK / ER COLLET CHUCK



HSK / ER 立銑刀夾頭

(DIN 69893-5)
(DIN ISO 15488)



T W PAT NO. M298033
T W PAT NO. M311791
J P PAT NO. 3128766
K R PAT NO. 20-0433603
C N PAT NO. ZL200620132661.0
C H PAT NO. 696550
T R PAT NO. TR 2007 02942 Y
I T PAT NO. N.0000266731

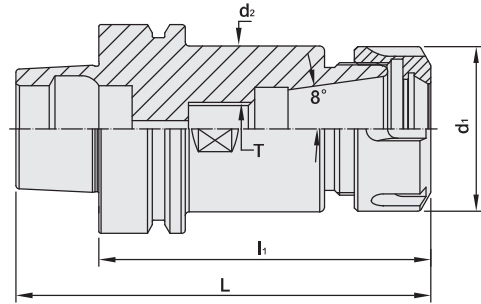

MODEL NO.	TYPE	L	l ₁	d ₁	d ₂ MAX.	T	SIZE RANGE	WEIGHT (KGS)
31376 - E	HSK40E x ER16A - 65	85	65	28	34	M10 x 1.5P	1 ~ 10	0.35
31378 - E	HSK40E x ER20A - 60	80	60	34	34	-	1 ~ 13	0.35
31380 - E	HSK40E x ER20A - 100	120	100	34	34	M10 x 1.5P	1 ~ 13	0.45
31383 - E	HSK40E x ER25 - 75	95	75	42	34	M10 x 1.5P	1 ~ 16	0.40
31386 - E	HSK40E x ER32 - 100	120	100	50	34	M16 x 2.0P	2 ~ 20	0.92
31402 - E	HSK50E x ER16A - 80	105	80	28	42	M10 x 1.5P	1 ~ 10	0.50
31408 - E	HSK50E x ER20A - 80	105	80	34	42	M12 x 1.75P	1 ~ 13	0.60
31419 - E	HSK50E x ER32 - 85	110	85	50	42	-	2 ~ 20	1.30
31456 - E	HSK63E x ER32 - 90	122	90	50	53	M16 x 2.0P	2 ~ 20	2.50
31467 - E	HSK63E x ER40 - 75	107	75	63	53	-	3 ~ 26	2.65
31472 - E	HSK63E x ER40 - 120	152	120	63	53	M20 x 2.0P	3 ~ 26	2.77

Features:

- ▶ Revolution of every tool holder is checked by a balancing machine.

Product information:

- ▶ Balance: G2.5 25,000 rpm. Higher balancing grade and revolution can be done upon request but additional charge is needed.

Standard Accessory: • NUT

Collet	Nut	Preset Screw	Spanner
P.W-6~24	P.W-42	P.W-82	P.W-62~65



HSK / SKX COLLET CHUCK

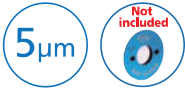

HSK / SKX 立銑刀夾頭

(DIN 69893-5)



Fig.1

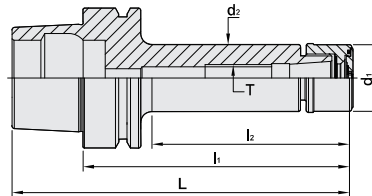
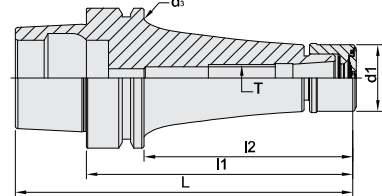

Fig.2



MODEL NO.	TYPE	L	l ₁	l ₂	d ₁	d ₂	d ₃	T	SIZE RANGE	Fig.	WEIGHT (KGS)
97.790.06.045	HSK25E x SKX6 - 45	58	45	34	18	18	-	-	3 ~ 6	1	0.10
97.790.10.055	HSK25E x SKX10 - 55	68	55	35	30	30	-	-	3 ~ 10	1	0.18
98.790.06.060	HSK32E x SKX6 - 60	76	60	36	18	18	-	-	3 ~ 6	1	0.17
98.790.10.060	HSK32E x SKX10 - 60	76	60	25	30	30	-	M6 x 1.0P	3 ~ 10	1	0.26
98.790.10.075	HSK32E x SKX10 - 75	91	75	40	30	30	-	M6 x 1.0P	3 ~ 10	1	0.30
99.790.06.060	HSK40E x SKX6 - 60	80	60	35	18	18	-	-	3 ~ 6	1	0.28
99.790.10.060	HSK40E x SKX10 - 60	80	60	38	30	30	-	M6 x 1.0P	3 ~ 10	1	0.40
99.790.10.075	HSK40E x SKX10 - 75	95	75	53	30	30	-	M6 x 1.0P	3 ~ 10	1	0.50
99.790.16.080	HSK40E x SKX16 - 80	100	80	45	40	40	-	-	3 ~ 16	1	0.60
100.790.06.060	HSK50E x SKX6 - 60	85	60	29	18	18	-	-	3 ~ 6	1	0.50
100.790.06.080	HSK50E x SKX6 - 80	105	80	49	18	18	-	M6 x 1.0P	3 ~ 6	1	0.60
100.790.10.060	HSK50E x SKX10 - 60	85	60	29	30	30	-	-	3 ~ 10	1	0.50
100.790.10.105	HSK50E x SKX10 - 105	130	105	74	30	30	-	M10 x 1.5P	3 ~ 10	1	0.70
100.790.16.080	HSK50E x SKX16 - 80	105	80	53	40	40	-	-	3 ~ 16	1	0.60
100.790.16.120	HSK50E x SKX16 - 120	145	120	92	40	40	-	M16 x 2.0P	3 ~ 16	1	1.10
101.790.06.100	HSK63E x SKX6 - 100	132	100	69	18	18	-	M6 x 1.0P	3 ~ 6	1	0.90
101.790.06.120	HSK63E x SKX6 - 120	152	120	94	18	18	53	M6 x 1.0P	3 ~ 6	2	1.00
101.790.10.105	HSK63E x SKX10 - 105	137	105	74	30	30	-	M10 x 1.5P	3 ~ 10	1	1.30
101.790.10.120	HSK63E x SKX10 - 120	152	120	94	30	30	53	M10 x 1.5P	3 ~ 10	2	1.50
101.790.10.150	HSK63E x SKX10 - 150	182	150	24	30	30	53	M10 x 1.5P	3 ~ 10	2	1.70
101.790.16.120	HSK63E x SKX16 - 120	152	120	94	40	40	-	M18 x 1.5P	3 ~ 16	1	1.70
101.790.16.150	HSK63E x SKX16 - 150	182	150	124	40	40	53	M18 x 1.5P	3 ~ 16	2	1.80
101.790.20.120	HSK63E x SKX20 - 120	152	120	94	48.5	48.5	53	M22 x 1.5P	3 ~ 20	2	1.80
101.790.20.135	HSK63E x SKX20 - 135	167	135	109	48.5	48.5	53	M22 x 1.5P	3 ~ 20	2	2.00
101.790.25.135	HSK63E x SKX25 - 135	167	135	109	55	-	-	M28 x 2.0P	3 ~ 25.4	1	1.90

Features:

- ▶ SKX sealed cap is optional. Please order SKX sealed cap additionally.
- ▶ With the design of SKX sealed cap, coolant pressure capable up to 70 bar.
- ▶ Used with coolant-through tools.
- ▶ Balance: G2.5 25,000rpm.

Standard Accessory: • NUT

Collet	Nut	Cap	Preset Screw	Spanner	Sealed Cap Spanner
P.W-25	P.W-49	P.W-50	P.W-82	P.W-62~67	P.W-66



HSK / SK3 COLLET CHUCK

5 μ m

HSK / SK3 高速機專用夾頭

[DIN 69893-5]

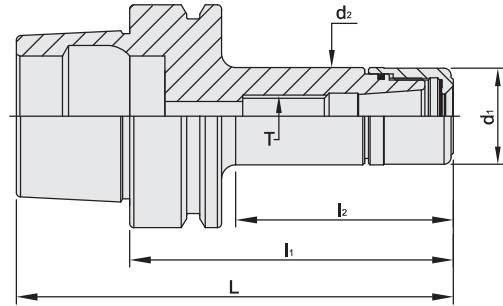

MODEL NO.	TYPE	L	l ₁	l ₂	d ₁	d ₂	T	SIZE RANGE	WEIGHT (KGS)
97.763.06.040	HSK25E x SK306 - 40	53	40	29	19.5	19.5	-	3 ~ 6	0.50
97.763.06.060	HSK25E x SK306 - 60	73	60	49	19.5	19.5	M8 x 1.25P	3 ~ 6	0.70
98.763.06.045	HSK32E x SK306 - 45	61	45	24	19.5	19.5	-	3 ~ 6	0.50
98.763.06.060	HSK32E x SK306 - 60	76	60	38	19.5	19.5	M8 x 1.25P	3 ~ 6	0.70
99.763.06.045	HSK40E x SK306 - 45	65	45	24	19.5	19.5	-	3 ~ 6	0.70
99.763.06.060	HSK40E x SK306 - 60	80	60	38	19.5	19.5	M8 x 1.25P	3 ~ 6	0.80
99.763.06.075	HSK40E x SK306 - 75	95	75	53	19.5	19.5	M8 x 1.25P	3 ~ 6	0.90
99.763.10.060	HSK40E x SK310 - 60	80	60	38	27.5	27.5	-	3 ~ 10	0.90
99.763.10.075	HSK40E x SK310 - 75	95	75	53	27.5	27.5	M12 x 1.75P	3 ~ 10	1.00
99.763.13.060	HSK40E x SK313 - 60	80	60	39	33	33	-	3 ~ 13	0.90
99.763.13.075	HSK40E x SK313 - 75	95	75	54	33	33	-	3 ~ 13	1.00
99.763.16.075	HSK40E x SK316 - 75	95	75	40	40	40	-	3 ~ 16	1.00
100.763.06.060	HSK50E x SK306 - 60	85	60	32	19.5	19.5	M8 x 1.25P	3 ~ 6	1.00
100.763.06.075	HSK50E x SK306 - 75	100	75	44	19.5	19.5	M8 x 1.25P	3 ~ 6	1.20
100.763.06.090	HSK50E x SK306 - 90	115	90	59	19.5	19.5	M8 x 1.25P	3 ~ 6	1.40
100.763.10.060	HSK50E x SK310 - 60	85	60	33	27.5	27.5	-	3 ~ 10	0.90
100.763.10.075	HSK50E x SK310 - 75	100	75	44	27.5	27.5	M12 x 1.75P	3 ~ 10	1.00
100.763.10.090	HSK50E x SK310 - 90	115	90	59	27.5	27.5	M12 x 1.75P	3 ~ 10	1.20
100.763.13.060	HSK50E x SK313 - 60	85	60	33	33	33	-	3 ~ 13	0.90
100.763.13.075	HSK50E x SK313 - 75	100	75	46	33	33	M12 x 1.75P	3 ~ 13	1.00
100.763.13.090	HSK50E x SK313 - 90	115	90	61	33	33	M12 x 1.75P	3 ~ 13	1.20
100.763.16.075	HSK50E x SK316 - 75	100	75	48	40	40	-	3 ~ 16	1.00
100.763.16.090	HSK50E x SK316 - 90	115	90	63	40	40	M18 x 1.5P	3 ~ 16	1.20

Features:

- ▶ The length of SK3 clamping nut is longer and the front thread of SK3 collet chuck is designed with an O-ring, which prevents coolant fluid and metal chips from getting into the tool holder.
- ▶ SK3 is exchangeable with other brands of SKS collets on the market.

Product information:

- ▶ Balance: G2.5 25,000 rpm. Higher balancing grade and revolution can be done upon request but additional charge is needed.

Standard Accessory: • NUT

Collet	Nut	Preset Screw	Spanner
P.W-25~28	P.W-46	P.W-82	P.W-62~67



REFERENCE DETAILS

DIN 69893 - F

- ▶ Shank body standard: **DIN 69893 - 6**
- ▶ Taper tolerance < **AT3**
- ▶ Hardness > **HRC 56°**
- ▶ Surface roughness: Ra < **0.25 μm**
- ▶ Roundness < **0.6 μm**
- ▶ Carbon depth > **0.8mm**
- ▶ The shank has pre-balance at G6.3, and can provide precision balance at G2.5. It can be ordered by request.

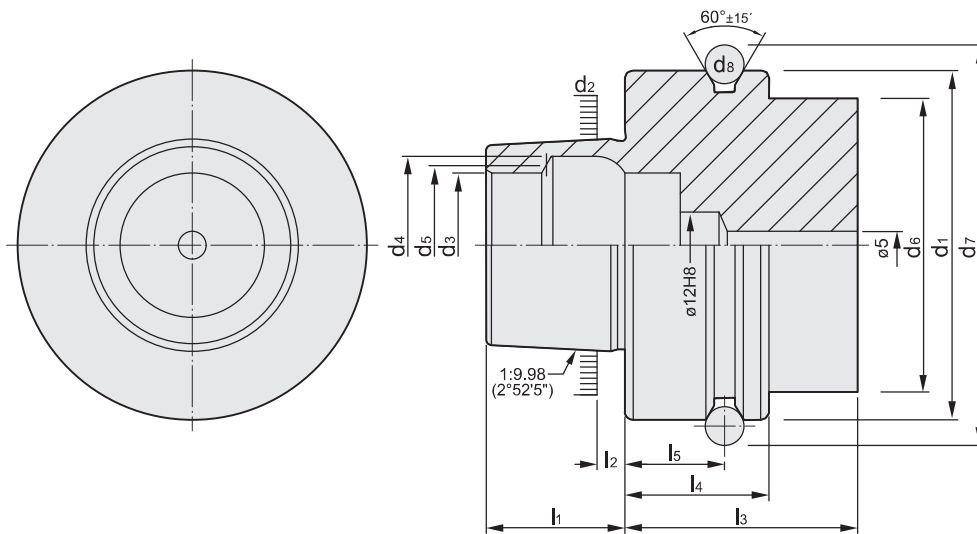

FROM F

HSK	d ₁ h10	d ₂	d ₃ H10	d ₄ H11	d ₅	d ₆ max.	d ₇ 0 -0.1
50	50	30.007	21	25.5	23	42	59.3
63	63	38.009	26	32	29	53	72.3
HSK	d ₈	l ₁ 0 -0.2	l ₂	l ₃ min.	l ₄ 0 -0.1	l ₅ ±0.1	
50	7	20	4	42	26	18	
63	7	25	5	42	26	18	





HSK / ER COLLET CHUCK

HSK / ER 立銑刀夾頭

(DIN 69893-6)
(DIN ISO 15488)



T W PAT NO. M298033
T W PAT NO. M311791
J P PAT NO. 3128766
K R PAT NO. 20-0433603
C N PAT NO. ZL200620132661.0
C H PAT NO. 696550
T R PAT NO. TR 2007 02942 Y
I T PAT NO. N.0000266731

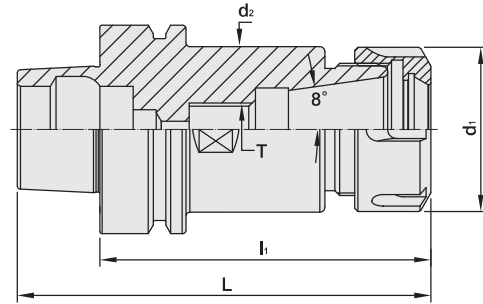

MODEL NO.	TYPE	L	li	d1	d2 MAX.	T	SIZE RANGE	WEIGHT (KGS)
31402 - F	HSK50F x ER16A - 80	100	80	28	42	M10 x 1.5P	1 ~ 10	0.50
31404 - F	HSK50F x ER16A - 100	120	100	28	42	M10 x 1.5P	1 ~ 10	0.55
31406 - F	HSK50F x ER16A - 120	140	120	28	42	M10 x 1.5P	1 ~ 10	0.70
31408 - F	HSK50F x ER20A - 80	100	80	34	42	M12 x 1.75P	1 ~ 13	0.60
31410 - F	HSK50F x ER20A - 100	120	100	34	42	M12 x 1.75P	1 ~ 13	0.65
31412 - F	HSK50F x ER20A - 120	140	120	34	42	M12 x 1.75P	1 ~ 13	0.70
31414 - F	HSK50F x ER25 - 80	100	80	42	42	M16 x 2.0P	1 ~ 16	0.70
31416 - F	HSK50F x ER25 - 100	120	100	42	42	M16 x 2.0P	1 ~ 16	0.80
31418 - F	HSK50F x ER25 - 135	155	135	42	42	M16 x 2.0P	1 ~ 16	0.90
31420 - F	HSK50F x ER32 - 100	120	100	50	42	M16 x 2.0P	2 ~ 20	1.35
31422 - F	HSK50F x ER32 - 135	155	135	50	42	M16 x 2.0P	2 ~ 20	1.50
31424 - F	HSK50F x ER32 - 160	180	160	50	42	M16 x 2.0P	2 ~ 20	1.70

Features:

- ▶ Revolution of every tool holder is checked by a balancing machine.

Product information:

- ▶ Balance: G2.5 25,000 rpm. Higher balancing grade and revolution can be done upon request but additional charge is needed.

Standard Accessory: • NUT

Collet	Nut	Preset Screw	Spanner
P.W-6~24	P.W-42	P.W-82	P.W-62~65



HSK / ER COLLET CHUCK



HSK / ER 立銑刀夾頭

(DIN 69893-6)
(DIN ISO 15488)



T W PAT NO. M298033
T W PAT NO. M311791
J P PAT NO. 3128766
K R PAT NO. 20-0433603
C N PAT NO. ZL200620132661.0
C H PAT NO. 696550
T R PAT NO. TR 2007 02942 Y
I T PAT NO. N.0000266731

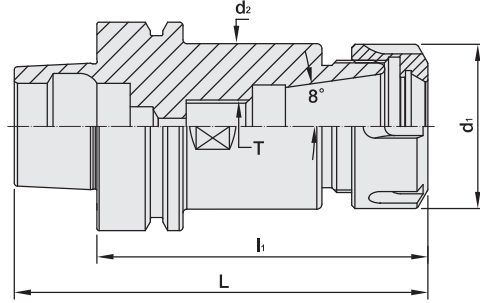

MODEL NO.	TYPE	L	li	d1	d2 MAX.	T	SIZE RANGE	WEIGHT (KGS)
31432 - F	HSK63F x ER16A - 80	105	80	28	53	M10 x 1.5P	1 ~ 10	1.50
31434 - F	HSK63F x ER16A - 100	125	100	28	53	M10 x 1.5P	1 ~ 10	1.55
31436 - F	HSK63F x ER16A - 120	145	120	28	53	M10 x 1.5P	1 ~ 10	1.70
31438 - F	HSK63F x ER16A - 160	185	160	28	53	M10 x 1.5P	1 ~ 10	1.90
31440 - F	HSK63F x ER20A - 80	105	80	34	53	M12 x 1.75P	1 ~ 13	1.60
31442 - F	HSK63F x ER20A - 100	125	100	34	53	M12 x 1.75P	1 ~ 13	1.70
31444 - F	HSK63F x ER20A - 120	145	120	34	53	M12 x 1.75P	1 ~ 13	1.80
31446 - F	HSK63F x ER20A - 160	185	160	34	53	M12 x 1.75P	1 ~ 13	2.00
31448 - F	HSK63F x ER25 - 80	105	80	42	53	M16 x 2.0P	1 ~ 16	1.70
31450 - F	HSK63F x ER25 - 100	125	100	42	53	M16 x 2.0P	1 ~ 16	1.80
31452 - F	HSK63F x ER25 - 120	145	120	42	53	M16 x 2.0P	1 ~ 16	2.00
31454 - F	HSK63F x ER25 - 150	175	150	42	53	M16 x 2.0P	1 ~ 16	2.30
30000 - F	HSK63F x ER32 - 70	95	70	50	53	-	2 ~ 20	2.50
31462 - F	HSK63F x ER32 - 100	125	100	50	53	M16 x 2.0P	2 ~ 20	2.55
31464 - F	HSK63F x ER32 - 145	170	145	50	53	M16 x 2.0P	2 ~ 20	2.70
31466 - F	HSK63F x ER32 - 160	185	160	50	53	M16 x 2.0P	2 ~ 20	3.10
30001 - F	HSK63F x ER40 - 75	100	75	63	53	-	3 ~ 26	2.65
31470 - F	HSK63F x ER40 - 100	125	100	63	53	M20 x 2.0P	3 ~ 26	2.70
31472 - F	HSK63F x ER40 - 120	145	120	63	53	M20 x 2.0P	3 ~ 26	2.77
31474 - F	HSK63F x ER40 - 150	175	150	63	53	M20 x 2.0P	3 ~ 26	2.95
31476 - F	HSK63F x ER40 - 170	195	170	63	53	M20 x 2.0P	3 ~ 26	3.10
31478 - F	HSK63F x ER50 - 120	145	120	78	53	M24 x 2.0P	5 ~ 34	3.50

Features:

► Revolution of every tool holder is checked by a balancing machine.

Product information:

► Balance: G2.5 25,000 rpm. Higher balancing grade and revolution can be done upon request but additional charge is needed.

Standard Accessory: • NUT

Collet	Nut	Preset Screw	Spanner
P.W-6~24	P.W-42	P.W-82	P.W-62~65



HSK / SKX COLLET CHUCK



HSK / SKX 立銑刀夾頭

[DIN 69893-6]



Fig.1

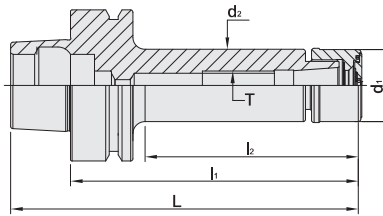
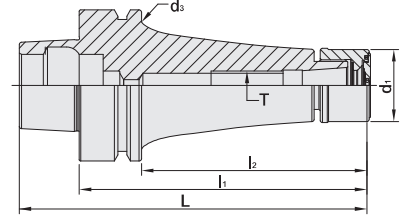

Fig.2



MODEL NO.	TYPE	L	l ₁	l ₂	d ₁	d ₂	d ₃	T	SIZE RANGE	Fig.	WEIGHT (KGS)
103.790.10.090	HSK63F x SKX10 - 90	115	90	60	30	30	-	M12 x 1.75P	3 ~ 10	1	0.86
103.790.10.105	HSK63F x SKX10 - 105	130	105	75	30	30	-	M12 x 1.75P	3 ~ 10	1	0.94
103.790.16.090	HSK63F x SKX16 - 90	115	90	59	40	40	-	M18 x 1.5P	3 ~ 16	1	0.96
103.790.16.105	HSK63F x SKX16 - 105	130	105	74	40	40	-	M18 x 1.5P	3 ~ 16	1	1.08
103.790.16.120	HSK63F x SKX16 - 120	145	120	94	40	40	53	M18 x 1.5P	3 ~ 16	2	1.30
103.790.20.120	HSK63F x SKX20 - 120	145	120	81	48.5	48.5	-	M22 x 1.5P	3 ~ 20	1	1.50
103.790.25.090	HSK63F x SKX25 - 90	115	90	48	55	55	-	-	3 ~ 25.4	1	1.12

Features:

- ▶ SKX sealed cap is optional. Please order SKX sealed cap additionally.
- ▶ With the design of SKX sealed cap, coolant pressure capable up to 70 bar.
- ▶ Used with coolant-through tools.
- ▶ Balance: G2.5 25,000rpm.

Standard Accessory: • NUT

Collet	Nut	Cap	Preset Screw	Spanner	Sealed Cap Spanner
P.W-25	P.W-49	P.W-50	P.W-82	P.W-62~67	P.W-66



REFERENCE DETAILS

DIN ISO 12164 - 3

- ▶ Shank body standard: **DIN ISO-12164-3:20008** ▶ Taper tolerance < **AT3**
- ▶ Hardness > **HRC 56°** ▶ Surface roughness: Ra < **0.25 μm**
- ▶ Roundness < **0.8 μm** ▶ Carbon depth > **0.8mm**
- ▶ The shank has pre-balance at G6.3, and can provide precision balance at G2.5. It can be ordered by request.

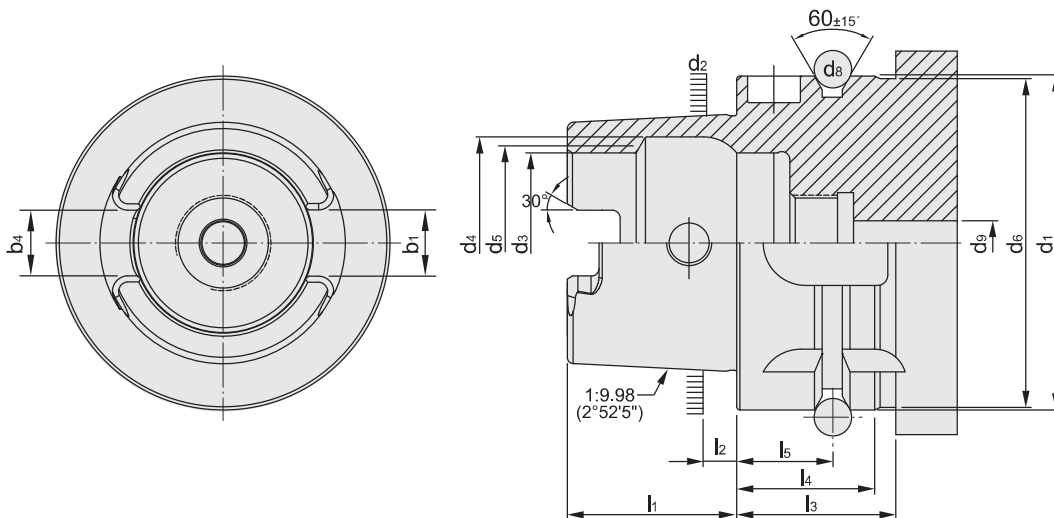

FROM T

HSK	d ₁ h10	d ₂	d ₃ H10	d ₄ H11	d ₅	d ₆ max.	d ₈	d ₉ max.
32	32	24.007	17	20.5	19	31	4	4.2
40	40	30.007	21	25.5	23	39	4	5
50	50	38.009	26	32	29	49	7	6.8
63	63	48.010	34	40	37	62	7	8.4
80	80	60.012	42	50	46	79	7	10.2
100	100	75.013	53	63	58	99	7	12
HSK	l ₁ 0 -0.2	l ₂	l ₃ min.	l ₄ 0 -0.1	l ₅ ±0.1	b ₁ +0.04 -0.04	b ₄	
32	16	3.2	23	20	16	7.05	6.932	+0.03 0
40	20	4	23	20	16	8.05	7.932	+0.03 0
50	25	5	30	26	18	10.54	10.425	+0.035 0
63	32	6.3	30	26	18	12.54	12.425	+0.035 0
80	40	8	30	26	18	16.04	15.93	+0.035 0
100	50	10	34	29	20	20.02	19.91	+0.035 0



DESIGNATION OF HSK-T TURNING TOOLS

HSK-T 編碼原則

CLAMP MECHANISM			
A	Back clamp system	M	Multi-clamp system
C	Clamp-on system	P	Pin lock system
D	Double clamp system	S	Screw-on system
E	Off-set pin system	T	Taper lock system
JS	Screw-on system	W	Wedge-on system
JT	Back clamp system		

INSERT CLEARANCE	
	A 3°
	B 5°
	C 7°
	D 15°
	E 20°
	F 25°
	G 30°
	N 0°
	P 11°

INSERT EDGE LENGTH						
Insert inscribed circle	6.35	7.94	9.525	12.00	12.70	
	80°	06	08	09	-	12
	55°	07	-	11	-	15
	35°	11	-	16	-	-
		-	-	-	12	-
		11	13	16	-	22
		-	-	09	-	12

HSK - T63 - M C L N R - 45 065 - 12

INSERT GEOMETRY		
C		80°
D		55°
K		55°
R		
S		
T		
V		35°
W		80°
L		
H		120°
A		85°
B		82°
E		75°
M		86°
O		135°
P		108°

CUTTING EDGE GEOMETRY			
A - 90°		M - 50°	
B - 75°		N - 63°	
C - 90°		P - 117.5°	
D - 45°		R - 75°	
E - 60°		S - 45°	
F - 90°		T - 60°	
G - 90°		U - 93°	
H - 107.5°		V - 72.5°	
J - 93°		W - 60°	
K - 75°		Y - 85°	
L - 95°			

HAND

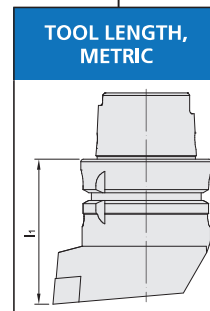
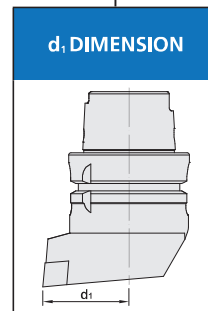

MCLN EXTERNAL TURNING TOOL

MCLN 外徑車刀

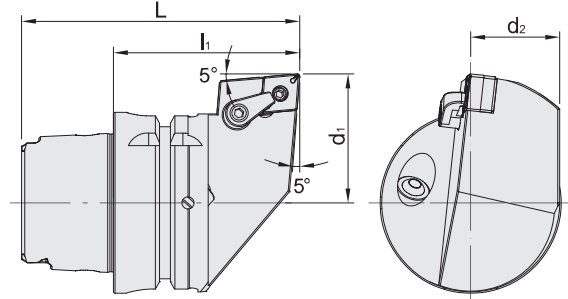

MODEL NO.	TYPE	L	l ₁	d ₁	d ₂	Insert	WEIGHT (KGS)
73T.475.12R.065	HSK-T63 - MCLNR - 45065 - 12	97	65	45	31	CN..1204	1.26
73T.475.12L.065	HSK-T63 - MCLNL - 45065 - 12	97	65	45	31	CN..1204	1.26

Product information:

► Inserts are optional accessories. Needs to be purchased additionally.

Accessory:

Insert	Clamp	Shim	Screw	Screw
CN..1204	MC620	CMS432	MS630	MLP46L-A

MDJN EXTERNAL TURNING TOOL

MDJN 外徑車刀

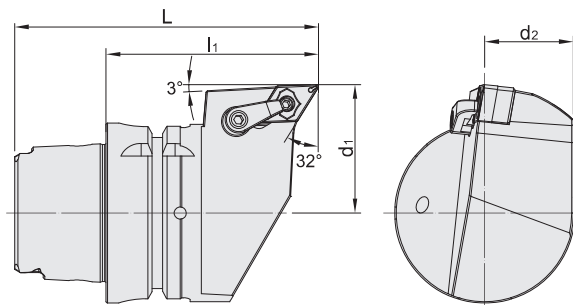

MODEL NO.	TYPE	L	l ₁	d ₁	d ₂	Insert	WEIGHT (KGS)
73T.476.15R.075	HSK-T63 - MDJNR - 45075 - 15	107	75	45	31	DN..1504	1.38
73T.476.15L.075	HSK-T63 - MDJNL - 45075 - 15	107	75	45	31	DN..1504	1.38

Product information:

► Inserts are optional accessories. Needs to be purchased additionally.

Accessory:

Insert	Clamp	Shim	Screw	Screw
DN..1504	MC622	DMS442	MS630	MLP46L-A



MTJN EXTERNAL TURNING TOOL

MTJN 外徑車刀

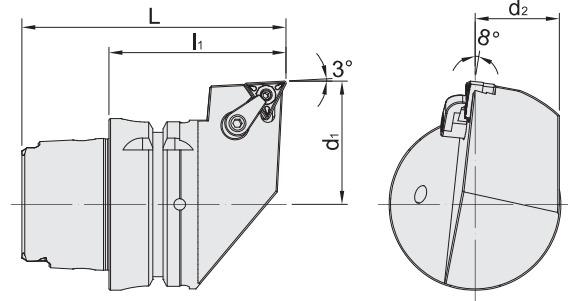

MODEL NO.	TYPE	L	l ₁	d ₁	d ₂	Insert	WEIGHT (KGS)
73T.477.16R.065	HSK-T63 - MTJNR - 45065 - 16	97	65	45	31	TN..1604	1.27
73T.477.16L.065	HSK-T63 - MTJNL - 45065 - 16	97	65	45	31	TN..1604	1.27

Product information:

► Inserts are optional accessories. Needs to be purchased additionally.

Accessory:

Insert	Clamp	Shim	Screw	Screw
TN..1604	MC620	TMS322	MS630	MLP34L-A

MWLN EXTERNAL TURNING TOOL

MWLN 外徑車刀

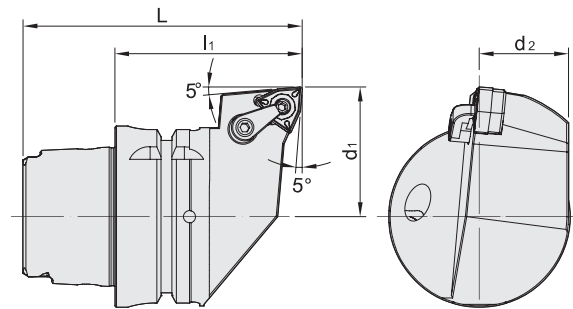

MODEL NO.	TYPE	L	l ₁	d ₁	d ₂	Insert	WEIGHT (KGS)
73T.478.08R.065	HSK-T63 - MWLNR - 45065 - 08	97	65	45	31	WN..0804	1.22
73T.478.08L.065	HSK-T63 - MWLNL - 45065 - 08	97	65	45	31	WN..0804	1.22

Product information:

► Inserts are optional accessories. Needs to be purchased additionally.

Accessory:

Insert	Clamp	Shim	Screw	Screw
WN..0804	MC620	WMS432	MS630	MLP46L-A

MVLN EXTERNAL TURNING TOOL

MVLN 外徑車刀

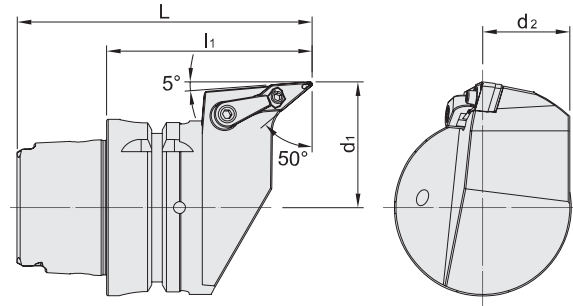

MODEL NO.	TYPE	L	l ₁	d ₁	d ₂	Insert	WEIGHT (KGS)
73T.479.16R.075	HSK-T63 - MVLNR - 45075 - 16	107	75	45	31	VN..1604	1.30
73T.479.16L.075	HSK-T63 - MVLNL - 45075 - 16	107	75	45	31	VN..1604	1.30

Product information:

► Inserts are optional accessories. Needs to be purchased additionally.

Accessory:

Insert	Clamp	Shim	Screw	Screw
				
VN..1604	MC622	VMS322	MS630	MLP34L-A

MCMN EXTERNAL TURNING TOOL

MCMN 外徑車刀

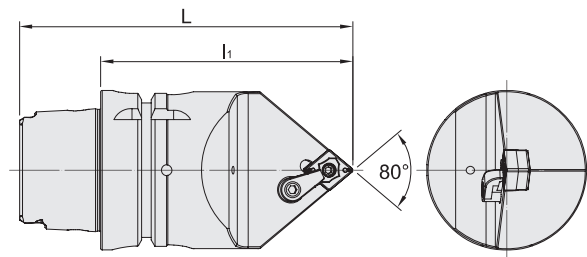

MODEL NO.	TYPE	L	l ₁	Insert	WEIGHT (KGS)
73T.480.12N.100	HSK-T63 - MCMNN - 00100 - 12	132	100	CN..1204	1.68
73T.480.12N.140	HSK-T63 - MCMNN - 00140 - 12	172	140	CN..1204	1.68

Product information:

► Inserts are optional accessories. Needs to be purchased additionally.

Accessory:

Insert	Clamp	Shim	Screw	Screw
				
CN..1204	MC620	CMS432	MS620	MLP46L-A



MDNN EXTERNAL TURNING TOOL

MDNN 外徑車刀

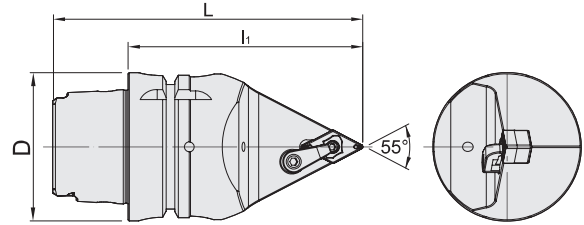

MODEL NO.	TYPE	L	l ₁	D	Insert	WEIGHT (KGS)
73T.481.15N.100	HSK-T63 - MDNNN - 00100 - 15	132	100	63	DN..1504	1.55
73T.481.15N.140	HSK-T63 - MDNNN - 00140 - 15	172	140	63	DN..1504	1.55

Product information:

► Inserts are optional accessories. Needs to be purchased additionally.

Accessory:

Insert	Clamp	Shim	Screw	Screw
				
DN..1504	MC622	DMS442	MS625	MLP46L-A

MTEN EXTERNAL TURNING TOOL

MTEN 外徑車刀

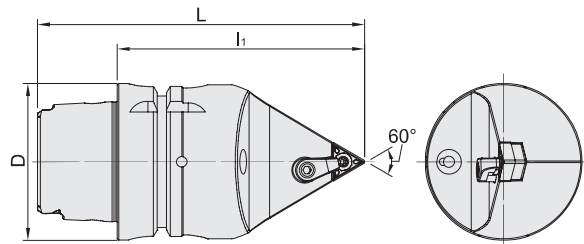

MODEL NO.	TYPE	L	l ₁	D	Insert	WEIGHT (KGS)
73T.482.16N.100	HSK-T63 - MTENN - 00100 - 16	132	100	63	TN..1604	1.62
73T.482.16N.140	HSK-T63 - MTENN - 00140 - 16	172	140	63	TN..1604	1.62

Product information:

► Inserts are optional accessories. Needs to be purchased additionally.

Accessory:

Insert	Clamp	Shim	Screw	Screw
				
TN..1604	MC620	TMS322	MS630	MLP34L-A

MWMN EXTERNAL TURNING TOOL

MWMN 外徑車刀

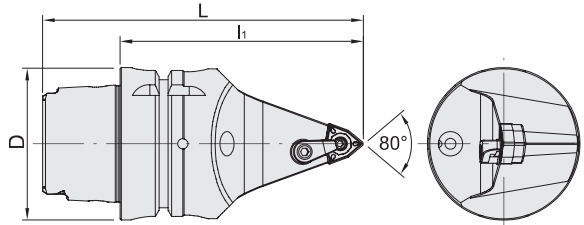

MODEL NO.	TYPE	L	l ₁	D	Insert	WEIGHT (KGS)
73T.483.08N.100	HSK-T63 - MWMN - 00100 - 08	132	100	63	WN..0804	1.48
73T.483.08N.140	HSK-T63 - MWMN - 00140 - 08	172	140	63	WN..0804	1.48

Product information:

► Inserts are optional accessories. Needs to be purchased additionally.

Accessory:

Insert	Clamp	Shim	Screw	Screw
WN..0804	MC620	WMS432	MS630	MLP46L-A

MVNV EXTERNAL TURNING TOOL

MVNV 外徑車刀

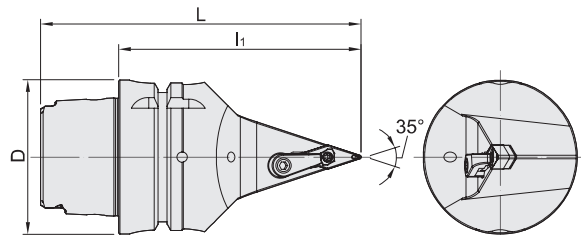

MODEL NO.	TYPE	L	l ₁	D	Insert	WEIGHT (KGS)
73T.484.16N.100	HSK-T63 - MVVNN - 00100 - 16	132	100	63	VN..1604	1.40
73T.484.16N.140	HSK-T63 - MVVNN - 00140 - 16	172	140	63	VN..1604	1.40

Product information:

► Inserts are optional accessories. Needs to be purchased additionally.

Accessory:

Insert	Clamp	Shim	Screw	Screw
VN..1604	MC622	VMS322	MS630	MLP34L-A



SIDE LOCK HOLDER

FOR INTERNAL TURNING BAR

SLT 側固式刀柄 [用於內徑車刀]

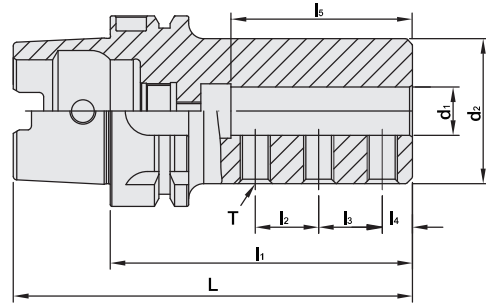

MODEL NO.	TYPE	L	l ₁	l ₂	l ₃	l ₄	l ₅	d ₁	d ₂	T	WEIGHT (KGS)
73T.797.08.070	HSK-T63 x SLT8 - 70	102	70	10	10	6	32	8	28	M6	0.93
73T.797.10.080	HSK-T63 x SLT10 - 80	112	80	12	12	8	40	10	35	M8	1.10
73T.797.12.090	HSK-T63 x SLT12 - 90	122	90	16	16	8	45	12	42	M8	1.36
73T.797.16.100	HSK-T63 x SLT16 - 100	132	100	21	21	10	60	16	48	M10	1.60
73T.797.20.120	HSK-T63 x SLT20 - 120	152	120	20	20	12	60	20	52	M10	2.03
73T.797.25.140	HSK-T63 x SLT25 - 140	172	140	23	23	14	67	25	56	M12	2.52
73T.797.32.160	HSK-T63 x SLT32 - 160	192	160	26	26	16	74	32	64	M12	3.34

► Use screws to change the coolant outlet from tool coolant hole or from tool holder.

	MODEL NO.	TYPE
<p>SCREW FOR COOLANT OUTLET FROM TOOL</p>	B06 - 01M4 x 0.7P - 503	SLT8
	B06 - 01M5 x 0.8P - 503	SLT10
	B06 - 01M6 x 1.0P - 603	SLT12, SLT16, SLT20
	B06 - 01M8 x 1.25P - 603	SLT25, SLT32
<p>SCREW FOR COOLANT OUTLET FROM TOOL HOLDER</p>	B05 - 03M6 x 1.0P - 803	M6 x 1.0P - 8L EBSS6-8

Product information:

► Both screws are standard accessories.



SIDE LOCK HOLDER

FOR HIGH SPEED DRILL

SLD 側固式刀柄 [用於快鑽]

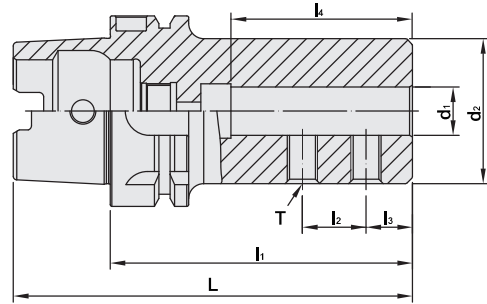

MODEL NO.	TYPE	L	l ₁	l ₂	l ₃	l ₄	d ₁	d ₂	T	WEIGHT (KGS)
73T.798.08.065	HSK-T63 x SLD8 - 65	97	65	18	10	34	8	28	M8	0.84
73T.798.10.070	HSK-T63 x SLD10 - 70	102	70	20	12	39	10	35	M8	0.97
73T.798.12.070	HSK-T63 x SLD12 - 70	102	70	20	12	39	12	42	M8	1.10
73T.798.16.075	HSK-T63 x SLD16 - 75	107	75	20	15	44	16	48	M10	1.26
73T.798.20.075	HSK-T63 x SLD20 - 75	107	75	20	15	44	20	52	M10	1.34
73T.798.25.085	HSK-T63 x SLD25 - 85	117	85	23	17	52	25	62	M12	1.79
73T.798.32.090	HSK-T63 x SLD32 - 90	122	90	27	17	56	32	62	M12	1.74
73T.798.40.100	HSK-T63 x SLD40 - 100	132	100	28	22	62	40	68	M16	2.00

EXTERNAL TURNING TOOL HOLDER

外徑車刀架

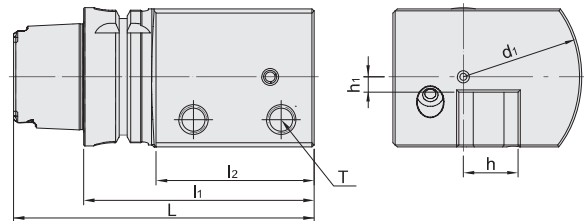

MODEL NO.	TYPE	L	l ₁	l ₂	d ₁	h	h ₁	T	WEIGHT (KGS)
73T.S25R.105	HSK-T63 x S25R - 105	137	105	70	54	25	6	M12 x 1.75P	3.40
73T.S25L.105	HSK-T63 x S25L - 105	137	105	70	54	25	6	M12 x 1.75P	3.40

EXTERNAL TURNING TOOL HOLDER

SV 外徑車刀架

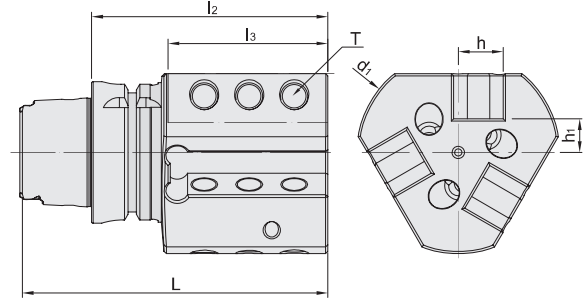

MODEL NO.	TYPE	L	l ₂	l ₃	d ₁	h	h ₁	T	WEIGHT (KGS)
73T.SV20R.105	HSK-T63 x SV20R - 105	137	105	70	90	20	15	M12 x 1.75P	2.72
73T.SV20L.105	HSK-T63 x SV20L - 105	137	105	70	90	20	15	M12 x 1.75P	2.72

EXTERNAL TURNING TOOL HOLDER

SB 外徑車刀架

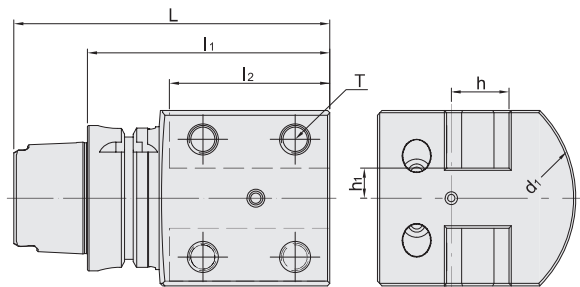

MODEL NO.	TYPE	L	l ₁	l ₂	h	h ₁	d ₁	T	WEIGHT (KGS)
73T.SB25R.105	HSK-T63 x SB25R - 105	137	105	70	25	13	54	M12 x 1.75P	2.98

EXTERNAL TURNING TOOL HOLDER

SF 外徑車刀架

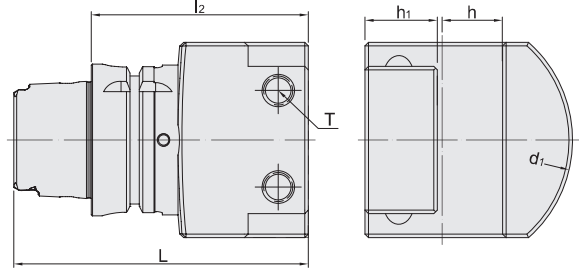

MODEL NO.	TYPE	L	l ₂	h	h ₁	d ₁	T	WEIGHT (KGS)
73T.SF25.090	HSK-T63 x SF25 - 90	122	90	25	30	54	M12 x 1.75P	3.05
73T.SF25.120	HSK-T63 x SF25 - 120	152	120	25	30	54	M12 x 1.75P	3.99

EXTERNAL TURNING TOOL HOLDER

SN 外徑車刀架

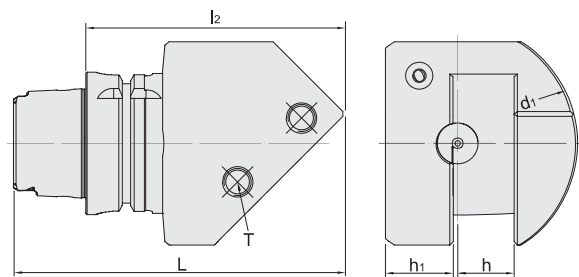

MODEL NO.	TYPE	L	l ₂	d ₁	h	h ₁	T	WEIGHT (KGS)
73T.SN25R.115	HSK-T63 x SN25R - 115	147	115	53	25	30	M12 x 1.75P	3.40
73T.SN25L.115	HSK-T63 x SN25L - 115	147	115	53	25	30	M12 x 1.75P	3.40

