

HBL CATEGORY

BT / HBL SLIM-FIT COLLET CHUCK	N-2
CAT / HBL SLIM-FIT COLLET CHUCK	N-3
DAT / HBL SLIM-FIT COLLET CHUCK	N-4
SBT / HBL SLIM-FIT COLLET CHUCK	N-5
SCAT / HBL SLIM-FIT COLLET CHUCK	N-6
SDAT / HBL SLIM-FIT COLLET CHUCK	N-7
HSK / HBL SLIM-FIT COLLET CHUCK	N-8
PSC / HBL SLIM-FIT COLLET CHUCK	N-9
HLB FACE CONTACT TYPE BALL NOSE FINISH END MILL CUTTER	N-10
HLB / FR FACE CONTACT TYPE BALL NOSE FINISH END MILL CUTTER	N-11
HLB / GR FACE CONTACT TYPE BALL NOSE FINISH END MILL CUTTER	N-12
HLB / HF POWERLOC SQUARE SHANK HIGH-FEED END MILL	N-13
HLB / SFC COLLET TYPE SHRINK FIT CHUCK	N-14~15
HLB / MAP FACE CONTACT TYPE 90° END MILL CUTTER	N-16
HLB / CMAP FACE CONTACT TYPE 90° END MILL CUTTER	N-17
HLB FACE CONTACT TYPE BALL NOSE FINISH END MILL CUTTER	N-18~19
HLB / PMB FACE CONTACT TYPE FINISH BORING HEAD	N-20
HLB / PCK FACE CONTACT TYPE ROUGH BORING HEAD	N-21
HLB / MCK FACE CONTACT TYPE BORING HEAD SHANK	N-22

BT / HBL SLIM-FIT COLLET CHUCK

BT / HBL 後拉式立銑刀夾頭



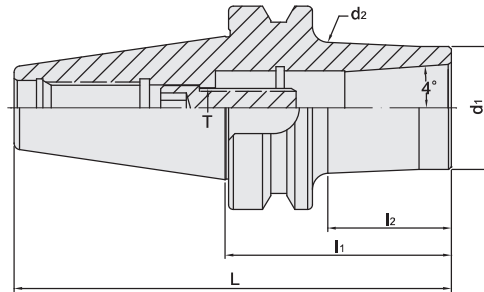

T W PAT NO. M488361
J P PAT NO. 3193771
D E PAT NO. Nr.202014103



MODEL NO.	TYPE	L	l ₁	l ₂	d ₁	d ₂	T	WEIGHT (KGS)
18858H	BT30 x HBL12 - 70	118.4	70	47	31.75	34.9	M10 x 1.5P	1.40
18860H	BT30 x HBL12 - 100	148.4	100	77	31.75	37.6	M10 x 1.5P	1.65
18862H	BT30 x HBL20 - 80	128.4	80	56	38.1	42.1	M12 x 1.75P	1.40
18864H	BT30 x HBL20 - 100	148.4	100	76	38.1	43.9	M12 x 1.75P	1.65
18870H	BT40 x HBL12 - 70	135.4	70	33	31.75	33.7	M10 x 1.5P	1.70
18872H	BT40 x HBL12 - 100	165.4	100	63	31.75	36.4	M10 x 1.5P	1.90
18874H	BT40 x HBL20 - 70	135.4	70	38	38.1	40.5	M12 x 1.75P	1.70
18876H	BT40 x HBL20 - 100	165.4	100	68	38.1	43.1	M12 x 1.75P	1.90
18877H	BT40 x HBL25 - 80	145.4	80	50	44.45	47.9	M16 x 2.0P	1.90
18877H-100	BT40 x HBL25 - 100	165.4	100	70	44.45	49.7	M16 x 2.0P	2.10
18882H	BT50 x HBL12 - 70	171.8	70	22	31.75	32.8	M10 x 1.5P	4.40
18884H	BT50 x HBL12 - 100	201.8	100	52	31.75	35.4	M10 x 1.5P	4.50
18886H	BT50 x HBL20 - 70	171.8	70	22	38.1	39.1	M12 x 1.75P	4.80
18888H	BT50 x HBL20 - 100	201.8	100	52	38.1	41.8	M12 x 1.75P	4.90
18890H	BT50 x HBL25 - 70	171.8	70	22	44.45	45.5	M16 x 2.0P	5.00
18890H-100	BT50 x HBL25 - 100	201.8	100	54	44.45	48.4	M16 x 2.0P	5.20

Product information:

- ▶ Balance: G2.5 25,000 rpm. Higher balancing grade and revolution can be done upon request but additional charge is needed.
- ▶ AD+B type is available, please inform us when making an order.
- ▶ MAS/BT30 tool holders are without coolant supply over collars.

Pull Stud	Spanner
	
P.W-54~55	P.W-66

CAT / HBL SLIM-FIT COLLET CHUCK

CAT / HBL 後拉式立銑刀夾頭



T W PAT NO. M488361
J P PAT NO. 3193771
D E PAT NO. Nr.202014103

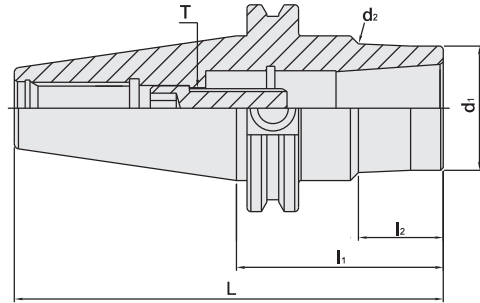

INCHES



MODEL NO.	TYPE	L	l ₁	l ₂	d ₁	d ₂	T	WEIGHT (KGS)
23660H	CAT40 x HBL12 - 2.5"	5.187	2.5	0.89	1.25	1.29	M10 x 1.5P	1.65
23662H	CAT40 x HBL12 - 4"	6.687	4	2.46	1.25	1.43	M10 x 1.5P	1.40
23666H	CAT40 x HBL20 - 2.5"	5.187	2.5	1.02	1.5	1.56	M12 x 1.75P	1.40
23668H	CAT40 x HBL20 - 4"	6.687	4	2.59	1.5	1.69	M12 x 1.75P	1.80
23671H	CAT40 x HBL25 - 3.25"	5.937	3.25	1.81	1.75	1.874	M16 x 2.0P	1.60
23671H - 4	CAT40 x HBL25 - 4"	6.687	4	2.529	1.75	1.936	M16 x 2.0P	1.80
23678H	CAT50 x HBL12 - 2.5"	6.5	2.5	1.12	1.25	1.30	M10 x 1.5P	4.20
23680H	CAT50 x HBL12 - 4.5"	8.5	4.5	2.75	1.25	1.46	M10 x 1.5P	4.30
23684H	CAT50 x HBL20 - 2.5"	6.5	2.5	0.93	1.5	1.55	M12 x 1.75P	4.50
23686H	CAT50 x HBL20 - 4.5"	8.5	4.5	2.93	1.5	1.72	M12 x 1.75P	4.80
23690H	CAT50 x HBL25 - 2.75"	6.75	2.75	1.316	1.75	1.831	M16 x 2.0P	4.60
23692H	CAT50 x HBL25 - 4.5"	8.5	4.5	3.066	1.75	1.983	M16 x 2.0P	4.80

Product information:

- ▶ Balance: G2.5 25,000 rpm. Higher balancing grade and revolution can be done upon request but additional charge is needed.
- ▶ AD+B type is available, please inform us when making an order.

Pull Stud	Spanner
	
P.W-56	P.W-66

DAT / HBL SLIM-FIT COLLET CHUCK

DAT / HBL 後拉式立銑刀夾頭



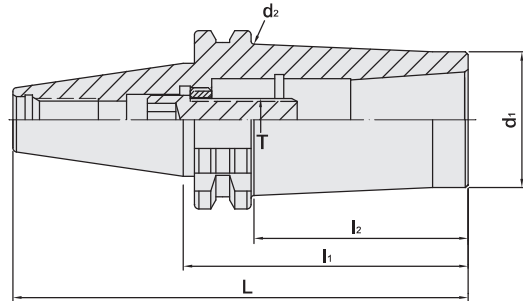

T W PAT NO. M488361
J P PAT NO. 3193771
D E PAT NO. Nr.202014103



MODEL NO.	TYPE	L	l ₁	l ₂	d ₁	d ₂	T	WEIGHT (KGS)
45356H	DAT30 x HBL12 - 70	117.8	70	48.03	31.75	35.23	M10 x 1.5P	0.62
45358H	DAT30 x HBL12 - 100	147.8	100	78.03	31.75	37.70	M10 x 1.5P	0.63
45362H	DAT30 x HBL20 - 80	127.8	80	60.14	38.1	42.48	M12 x 1.75P	0.64
45364H	DAT30 x HBL20 - 100	147.8	100	79.94	38.1	42.95	M12 x 1.75P	0.65
45372H	DAT40 x HBL12 - 70	138.4	70	41.34	31.75	34.49	M10 x 1.5P	1.40
45374H	DAT40 x HBL12 - 100	168.4	100	71.34	31.75	37.11	M10 x 1.5P	1.50
45376H	DAT40 x HBL20 - 70	138.4	70	46.12	38.1	41.25	M12 x 1.75P	1.50
45378H	DAT40 x HBL20 - 100	168.4	100	78.03	38.1	44.04	M12 x 1.75P	1.60
45379H	DAT40 x HBL25 - 80	148.4	80	58.03	44.45	48.6	M16 x 2.0P	1.70
45379H-100	DAT40 x HBL25 - 100	168.4	100	80.1	44.45	49.5	M16 x 2.0P	1.80
45384H	DAT50 x HBL12 - 70	171.75	70	41.34	31.75	34.49	M10 x 1.5P	3.20
45386H	DAT50 x HBL12 - 100	201.75	100	71.34	31.75	37.11	M10 x 1.5P	3.30
45388H	DAT50 x HBL20 - 70	171.75	70	41.34	38.1	40.84	M12 x 1.75P	3.40
45390H	DAT50 x HBL20 - 100	201.75	100	71.34	38.1	43.47	M12 x 1.75P	3.50
45392H	DAT50 x HBL25 - 70	171.75	70	46.1	44.45	47.6	M16 x 2.0P	3.50
45394H	DAT50 x HBL25 - 100	201.75	100	76.1	44.45	50.2	M16 x 2.0P	3.60

Product information:

- ▶ Balance: G2.5 25,000 rpm. Higher balancing grade and revolution can be done upon request but additional charge is needed.
- ▶ AD+B type is available, please inform us when making an order.
- ▶ #30 tool holders are without coolant supply over collars.

Pull Stud	Spanner
	
P.W-57	P.W-66

SBT / HBL SLIM-FIT COLLET CHUCK

Dual
DRIVE+

SBT / HBL 法蘭加厚型後拉式立銑刀夾頭

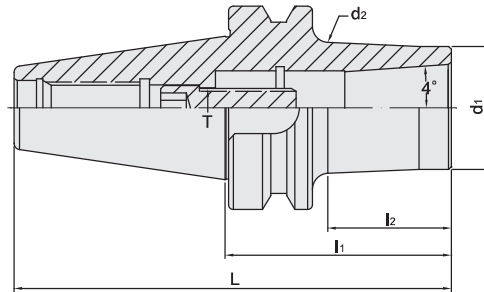

T W PAT NO. M488361
J P PAT NO. 3193771
D E PAT NO. Nr.202014103

MODEL NO.	TYPE	L	l ₁	l ₂	d ₁	d ₂	T	WEIGHT (KGS)
25.275.12.070	SBT30 x HBL12 - 70	118.4	70	47	31.75	34.9	M10 x 1.5P	1.40
25.275.12.100	SBT30 x HBL12 - 100	148.4	100	77	31.75	37.6	M10 x 1.5P	1.65
25.275.20.080	SBT30 x HBL20 - 80	128.4	80	56	38.1	42.1	M12 x 1.75P	1.40
25.275.20.100	SBT30 x HBL20 - 100	148.4	100	76	38.1	43.9	M12 x 1.75P	1.65
26.275.12.070	SBT40 x HBL12 - 70	135.4	70	33	31.75	33.7	M10 x 1.5P	1.70
26.275.12.100	SBT40 x HBL12 - 100	165.4	100	63	31.75	36.4	M10 x 1.5P	1.90
26.275.20.070	SBT40 x HBL20 - 70	135.4	70	38	38.1	40.5	M12 x 1.75P	1.70
26.275.20.100	SBT40 x HBL20 - 100	165.4	100	68	38.1	43.1	M12 x 1.75P	1.90
26.275.25.080	SBT40 x HBL25 - 80	145.4	80	50	44.45	47.9	M16 x 2.0P	1.90
26.275.25.100	SBT40 x HBL25 - 100	165.4	100	70	44.45	49.7	M16 x 2.0P	2.10
27.275.12.100	SBT50 x HBL12 - 70	171.8	70	22	31.75	32.8	M10 x 1.5P	4.40
27.275.12.100	SBT50 x HBL12 - 100	201.8	100	52	31.75	35.4	M10 x 1.5P	4.50
27.275.20.070	SBT50 x HBL20 - 70	171.8	70	22	38.1	39.1	M12 x 1.75P	4.80
27.275.20.100	SBT50 x HBL20 - 100	201.8	100	52	38.1	41.8	M12 x 1.75P	4.90
27.275.25.070	SBT50 x HBL25 - 70	171.8	70	22	44.45	45.5	M16 x 2.0P	5.00
27.275.25.100	SBT50 x HBL25 - 100	201.8	100	54	44.45	48.4	M16 x 2.0P	5.20

Product information:

- ▶ Balance: G2.5 25,000 rpm. Higher balancing grade and revolution can be done upon request but additional charge is needed.
- ▶ AD+B type is available, please inform us when making an order.
- ▶ SBT30 tool holders are without coolant supply over collars.

Pull Stud	Spanner
	
P.W-54~55	P.W-66

SCAT / HBL SLIM-FIT COLLET CHUCK

Dual
DRIVE+

SCAT / HBL 法蘭加厚型後拉式立銑刀夾頭

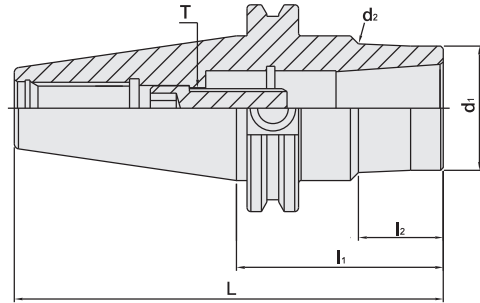



T W PAT NO. M488361
J P PAT NO. 3193771
D E PAT NO. Nr.202014103

INCHES

MODEL NO.	TYPE	L	l ₁	l ₂	d ₁	d ₂	T	WEIGHT (KGS)
43.275.12.250	SCAT40 x HBL12 - 2.5"	5.187	5.187	0.89	1.25	1.29	M10 x 1.5P	1.65
43.275.12.400	SCAT40 x HBL12 - 4"	6.687	6.687	2.46	1.25	1.43	M10 x 1.5P	1.40
43.275.20.250	SCAT40 x HBL20 - 2.5"	5.187	5.187	1.02	1.5	1.56	M12 x 1.75P	1.40
43.275.20.400	SCAT40 x HBL20 - 4"	6.687	6.687	2.59	1.5	1.69	M12 x 1.75P	1.80
43.275.25.325	SCAT40 x HBL25 - 3.25"	5.937	5.937	1.81	1.75	1.874	M16 x 2.0P	1.60
43.275.25.400	SCAT40 x HBL25 - 4"	6.687	6.687	2.529	1.75	1.936	M16 x 2.0P	1.80
44.275.12.250	SCAT50 x HBL12 - 2.5"	6.5	6.5	1.12	1.25	1.30	M10 x 1.5P	4.20
44.275.12.450	SCAT50 x HBL12 - 4.5"	8.5	8.5	2.75	1.25	1.46	M10 x 1.5P	4.30
44.275.20.250	SCAT50 x HBL20 - 2.5"	6.5	6.5	0.93	1.5	1.55	M12 x 1.75P	4.50
44.275.20.450	SCAT50 x HBL20 - 4.5"	8.5	8.5	2.93	1.5	1.72	M12 x 1.75P	4.80
44.275.25.275	SCAT50 x HBL25 - 2.75"	6.75	6.75	1.316	1.75	1.831	M16 x 2.0P	4.60
44.275.25.450	SCAT50 x HBL25 - 4.5"	8.5	8.5	3.066	1.75	1.983	M16 x 2.0P	4.80

Product information:

- ▶ Balance: G2.5 25,000 rpm. Higher balancing grade and revolution can be done upon request but additional charge is needed.
- ▶ AD+B type is available, please inform us when making an order.

Pull Stud	Spanner
	
P.W-56	P.W-66

SDAT / HBL SLIM-FIT COLLET CHUCK

Dual
DRIVE+

SDAT / HBL 法蘭加厚型後拉式立銑刀夾頭

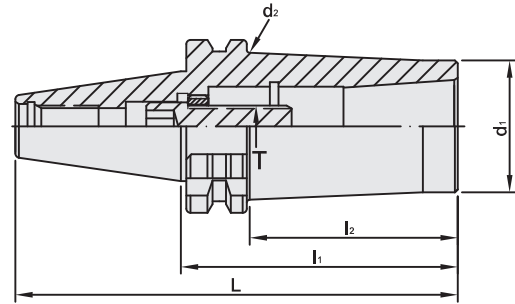



T W PAT NO. M488361
J P PAT NO. 3193771
D E PAT NO. Nr.202014103

MODEL NO.	TYPE	L	l ₁	l ₂	d ₁	d ₂	T	WEIGHT (KGS)
66.275.12.070	SDAT40 x HBL12 - 70	138.4	70	41.34	31.75	34.49	M10 x 1.5P	1.40
66.275.12.100	SDAT40 x HBL12 - 100	168.4	100	71.34	31.75	37.11	M10 x 1.5P	1.50
66.275.20.070	SDAT40 x HBL20 - 70	138.4	70	46.12	38.1	41.25	M12 x 1.75P	1.50
66.275.20.100	SDAT40 x HBL20 - 100	168.4	100	78.03	38.1	44.04	M12 x 1.75P	1.60
66.275.25.080	SDAT40 x HBL25 - 80	148.4	80	58.03	44.45	48.6	M16 x 2.0P	1.70
66.275.25.100	SDAT40 x HBL25 - 100	168.4	100	80.1	44.45	49.5	M16 x 2.0P	1.80
67.275.12.070	SDAT50 x HBL12 - 70	171.75	70	41.34	31.75	34.49	M10 x 1.5P	3.20
67.275.12.100	SDAT50 x HBL12 - 100	201.75	100	71.34	31.75	37.11	M10 x 1.5P	3.30
67.275.20.070	SDAT50 x HBL20 - 70	171.75	70	41.34	38.1	40.84	M12 x 1.75P	3.40
67.275.20.100	SDAT50 x HBL20 - 100	201.75	100	71.34	38.1	43.47	M12 x 1.75P	3.50
67.275.25.070	SDAT50 x HBL25 - 70	171.75	70	46.1	44.45	47.6	M16 x 2.0P	3.50
67.275.25.100	SDAT50 x HBL25 - 100	201.75	100	76.1	44.45	50.2	M16 x 2.0P	3.60

Product information:

- ▶ Balance: G2.5 25,000 rpm. Higher balancing grade and revolution can be done upon request but additional charge is needed.
- ▶ AD+B type is available, please inform us when making an order.

Pull Stud	Spanner
	
P.W-57	P.W-66

HSK / HBL SLIM-FIT COLLET CHUCK

HSK / HBL 後拉式立銑刀夾頭



T W PAT NO. M488361
J P PAT NO. 3193771
D E PAT NO. Nr.202014103

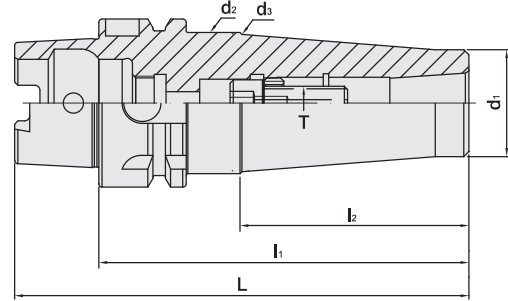

MODEL NO.	TYPE	L	l ₁	l ₂	d ₁	d ₂	d ₃	T	WEIGHT (KGS)
35456H	HSK50A x HBL12 - 110	135	110	68	31,75	42	40,79	M10 x 1,5P	1,70
35458H	HSK50A x HBL12 - 130	155	130	75,12	31,75	42	-	M10 x 1,5P	2,05
35460H	HSK50A x HBL20 - 120	145	120	54,66	38,1	42	-	M12 x 1,75P	2,00
35462H	HSK50A x HBL20 - 150	175	150	54,45	38,1	42	-	M12 x 1,75P	2,20
35476H	HSK63A x HBL12 - 110	142	110	79,22	31,75	37,79	-	M10 x 1,5P	2,00
35478H	HSK63A x HBL12 - 150	182	150	119,22	31,75	41,29	-	M10 x 1,5P	2,20
35480H	HSK63A x HBL20 - 120	152	120	89,22	38,1	45,02	-	M12 x 1,75P	2,20
35482H	HSK63A x HBL20 - 140	172	140	111,13	38,1	45	-	M12 x 1,75P	2,65
35494H	HSK100A x HBL12 - 120	170	120	79,05	31,75	37,78	-	M10 x 1,5P	2,60
35496H	HSK100A x HBL20 - 135	185	135	89,02	38,1	45	-	M12 x 1,75P	2,94
35498H	HSK100A x HBL25 - 150	200	150	118,13	44,45	53,89	-	M24 x 1,5P	3,00

Product information:

- ▶ Balance: G2.5 25,000 rpm. Higher balancing grade and revolution can be done upon request but additional charge is needed.

Spanner



P.W-66

PSC / HBL SLIM-FIT COLLET CHUCK

PSC / HBL 後拉式立銑刀夾頭



台灣精品2012
TAWAN EXCELLENCE



T W PAT NO. M488361
J P PAT NO. 3193771
D E PAT NO. Nr.202014103

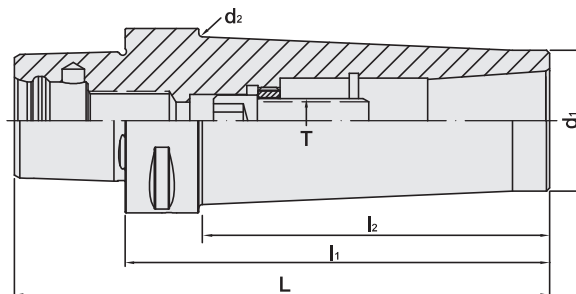

MODEL NO.	TYPE	L	l ₁	l ₂	d ₁	d ₂	T	WEIGHT (KGS)
140.275.12.090	PSC32 x HBL12 - 90	109	90	75	31.75	32	M10 x 1.5P	0.55
141.275.12.090	PSC40 x HBL12 - 90	114	90	68.4	31.75	36.85	M10 x 1.5P	0.64
141.275.20.105	PSC40 x HBL20 - 105	129	105	85	38.1	40	M12 x 1.75P	0.82
142.275.12.105	PSC50 x HBL12 - 105	135	105	82.1	31.75	38.04	M10 x 1.5P	0.98
142.275.20.115	PSC50 x HBL20 - 115	145	115	94.04	38.1	45.3	M12 x 1.75P	0.99
142.275.25.120	PSC50 x HBL25 - 120	150	120	100	44.45	50	M16 x 2.0P	1.48
143.275.12.100	PSC63 x HBL12 - 100	138	100	69.9	31.75	36.9	M10 x 1.5P	1.26
143.275.20.120	PSC63 x HBL20 - 120	158	120	91.4	38.1	45.2	M12 x 1.75P	1.47
143.275.25.120	PSC63 x HBL25 - 120	158	120	92.6	44.45	51.6	M16 x 2.0P	1.60

Product information:

- ▶ Balance: G2.5 25,000 rpm. Higher balancing grade and revolution can be done upon request but additional charge is needed.

Spanner



P.W-66

HLB FACE CONTACT TYPE BALL NOSE FINISH END MILL CUTTER

HLB / R 端面緊貼型圓刃刀具

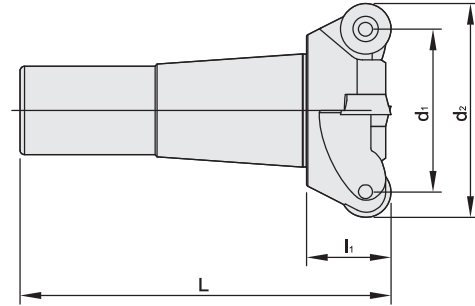

T W PAT NO. M488361
J P PAT NO. 3193771
D E PAT NO. Nr.202014103

W/O Coolant

MODEL NO.	TYPE	L	l ₁	d ₁	d ₂	TEETH	INSERT	WEIGHT (KGS)
262.35.86.R12	HLB20 x R12 - 2"	88	20	38.8	50.8	4	RD..1204	0.33
263.35.86.R12	HLB25 x R12 - 2"	98	20	38.8	50.8	4	RD..1204	0.45

Coolant Thru

262.35C.86.R12	HLB20 x RC12 - 2"	88	20	38.8	50.8	4	RD..1204	0.33
263.35C.86.R12	HLB25 x RC12 - 2"	98	20	38.8	50.8	4	RD..1204	0.45

ACCESSORIES

INSERT	SCREW	WRENCH
RD..1204	M4-10-5.7-60	T15

Product information:

- ▶ Inserts are optional accessories. Need to be purchased additionally.

HLB / FR FACE CONTACT TYPE BALL NOSE FINISH END MILL CUTTER

HLB / FR 端面緊貼型圓刃刀具

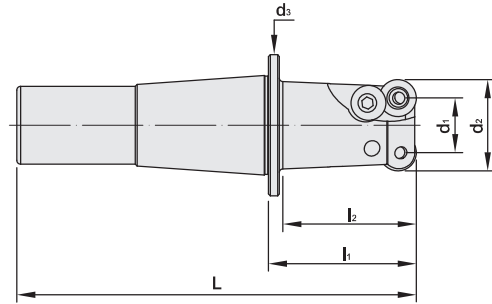

T W PAT NO. M488361

W/O Coolant

MODEL NO.	TYPE	L	l ₁	l ₂	d ₁	d ₂	d ₃	TEETH	INSERT	WEIGHT (KGS)
262.158.25.040	HLB20 x FR25 - 40	108	40	36	15	25	38.1	2	RP.1003	0.28
262.158.30.040	HLB20 x FR30 - 40	108	40	36	20	30	38.1	2	RP.1003	0.31
262.158.32.040	HLB20 x FR32 - 40	108	40	36	22	32	38.1	3	RP.1003	0.33
262.158.35.040	HLB20 x FR35 - 40	108	40	36	25	35	38.1	3	RP.1003	0.35
263.158.25.040	HLB25 x FR25 - 40	108	40	36	15	25	44.45	2	RP.1003	0.36
263.158.30.040	HLB25 x FR30 - 40	108	40	36	20	30	44.45	2	RP.1003	0.39
263.158.32.040	HLB25 x FR32 - 40	108	40	36	22	32	44.45	3	RP.1003	0.41
263.158.35.040	HLB25 x FR35 - 40	108	40	36	25	35	44.45	3	RP.1003	0.43

Coolant Thru

262.158C.25.040	HLB20 x FRC25 - 40	108	40	36	15	25	38.1	2	RP.1003	0.28
262.158C.30.040	HLB20 x FRC30 - 40	108	40	36	20	30	38.1	2	RP.1003	0.31
262.158C.32.040	HLB20 x FRC32 - 40	108	40	36	22	32	38.1	3	RP.1003	0.33
262.158C.35.040	HLB20 x FRC35 - 40	108	40	36	25	35	38.1	3	RP.1003	0.35
263.158C.25.040	HLB25 x FRC25 - 40	108	40	36	15	25	44.45	2	RP.1003	0.36
263.158C.30.040	HLB25 x FRC30 - 40	108	40	36	20	30	44.45	2	RP.1003	0.39
263.158C.32.040	HLB25 x FRC32 - 40	108	40	36	22	32	44.45	3	RP.1003	0.41
263.158C.35.040	HLB25 x FRC35 - 40	108	40	36	25	35	44.45	3	RP.1003	0.43

ACCESSORIES

INSERT	SCREW	CLAMP	CLAMP SCREW	WRENCH
RP.1003	M4-10-5.7-60	HR-5R	M5-0.8P	T15

Product information:

- ▶ Inserts are optional accessories. Need to be purchased additionally.

HLB / GR FACE CONTACT TYPE BALL NOSE FINISH END MILL CUTTER

HLB / GR 端面緊貼型圓刃刀具

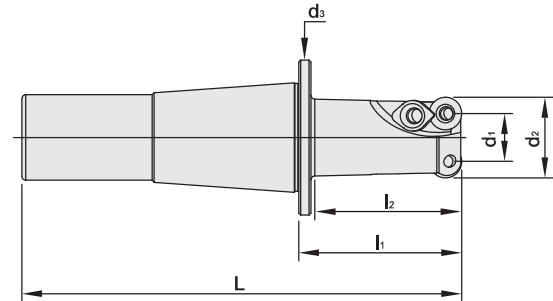

T W PAT NO. M488361

W/O Coolant

MODEL NO.	TYPE	L	l ₁	l ₂	d ₁	d ₂	d ₃	TEETH	INSERT	WEIGHT (KGS)
262.260.25.040	HLB20 x GR25 - 40	108	40	36	15	25	38.1	2	RD..0802	0.28
262.260.30.040	HLB20 x GR30 - 40	108	40	36	20	30	38.1	2	RD..10T3	0.31
262.260.32.040	HLB20 x GR32 - 40	108	40	36	22	32	38.1	3	RD..10T3	0.33
262.260.35.040	HLB20 x GR35 - 40	108	40	36	25	35	38.1	3	RD..10T3	0.35
263.260.25.040	HLB25 x GR25 - 40	108	40	36	15	25	44.45	2	RD..0802	0.36
263.260.30.040	HLB25 x GR30 - 40	108	40	36	20	30	44.45	2	RD..10T3	0.40
263.260.32.040	HLB25 x GR32 - 40	108	40	36	22	32	44.45	3	RD..10T3	0.42
263.260.35.040	HLB25 x GR35 - 40	108	40	36	25	35	44.45	3	RD..10T3	0.44

Coolant Thru

262.260C.25.040	HLB20 x GRC25 - 40	108	40	36	15	25	38.1	2	RD..0802	0.28
262.260C.30.040	HLB20 x GRC30 - 40	108	40	36	20	30	38.1	2	RD..10T3	0.31
262.260C.32.040	HLB20 x GRC32 - 40	108	40	36	22	32	38.1	3	RD..10T3	0.33
262.260C.35.040	HLB20 x GRC35 - 40	108	40	36	25	35	38.1	3	RD..10T3	0.35
263.260C.25.040	HLB25 x GRC25 - 40	108	40	36	15	25	44.45	2	RD..0802	0.36
263.260C.30.040	HLB25 x GRC30 - 40	108	40	36	20	30	44.45	2	RD..10T3	0.40
263.260C.32.040	HLB25 x GRC32 - 40	108	40	36	22	32	44.45	3	RD..10T3	0.42
263.260C.35.040	HLB25 x GRC35 - 40	108	40	36	25	35	44.45	3	RD..10T3	0.44

ACCESSORIES

INSERT	SCREW	CLAMP	CLAMP SCREW	WRENCH
RD..0802	M3-6.0-3.7-43	GR-5R	M3.5-8.0-5.5-60	T15
RD..10T3	M4-10-5.0-43	GR-5R	M3.5-8.0-5.5-60	T15

Product information:

- ▶ Inserts are optional accessories. Need to be purchased additionally.

HLB / HF POWERLOC SQUARE SHANK HIGH-FEED END MILL

HLB / HF 筒夾式大進給端銑刀



T W PAT NO. M488361

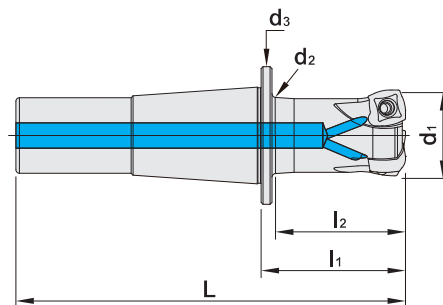

MODEL NO.	TYPE	d ₁	d ₂	d ₃	L	l ₁	l ₂	TEETH	INSERT	WEIGHT (KGS)
262.269.25.040	HLB20 x HF25 - 40 - 3T	25	20.918	38.1	107.3	40	35.2	3	SNKX09T3	0.38
262.269.32.040	HLB20 x HF32 - 40 - 3T	32	27.919	38.1	107.3	40	35.2	3	SNKX09T3	0.37
262.270.32.040	HLB20 x HF32 - 40 - 4T	32	27.919	38.1	107.3	40	35.2	4	SNKX09T3	0.37
263.269.25.040	HLB25 x HF25 - 40 - 3T	25	20.918	44.45	117.3	40	35.2	3	SNKX09T3	0.41
263.269.32.040	HLB25 x HF32 - 40 - 3T	32	27.919	44.45	117.3	40	35.2	3	SNKX09T3	0.51
263.270.32.040	HLB25 x HF32 - 40 - 4T	32	27.919	44.45	117.3	40	35.2	4	SNKX09T3	0.51

ACCESSORIES

INSERT	SCREW	WRENCH
SNKX09T3	M3.5-9.3-4.8-60	T5

Product information:

- ▶ Inserts are optional accessories. Need to be purchased additionally.

HLB / SFC COLLET TYPE SHRINK FIT CHUCK

HLB / SFC 筒夾式熱膨脹刀桿

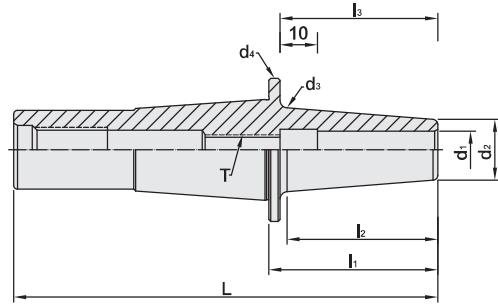

MODEL NO.	TYPE	L	li	l2	l3	d1	d2	d3	d4	T
261.651.03.045	HLB12 x SFC3 - 45	100	45	40.1	18	3	9	15.3	31.75	-
261.651.03.080	HLB12 x SFC3 - 80	135	80	75.1	18	3	9	20.8	31.75	-
261.651.03.110	HLB12 x SFC3 - 110	165	110	105.1	18	3	9	25.5	31.75	-
261.651.04.045	HLB12 x SFC4 - 45	100	45	40.1	20	4	10	16.3	31.75	-
261.651.04.080	HLB12 x SFC4 - 80	135	80	75.1	20	4	10	21.8	31.75	-
261.651.04.110	HLB12 x SFC4 - 110	165	110	105.1	20	4	10	26.5	31.75	-
261.651.05.045	HLB12 x SFC5 - 45	100	45	40.1	20	5	11	17.3	31.75	M4 x 0.7P
261.651.05.080	HLB12 x SFC5 - 80	135	80	75.1	20	5	11	22.8	31.75	M4 x 0.7P
261.651.05.110	HLB12 x SFC5 - 110	165	110	106	20	5	11	27.6	31.75	M4 x 0.7P
261.651.06.045	HLB12 x SFC6 - 45	100	45	40.1	36	6	12	18.3	31.75	M5 x 0.8P
261.651.06.080	HLB12 x SFC6 - 80	135	80	75.1	36	6	12	23.8	31.75	M5 x 0.8P
261.651.06.110	HLB12 x SFC6 - 110	165	110	106	36	6	12	28.6	31.75	M5 x 0.8P
261.651.08.045	HLB12 x SFC8 - 45	100	45	40.1	36	8	14	20.3	31.75	M6 x 1.0P
261.651.08.080	HLB12 x SFC8 - 80	135	80	76	36	8	14	25.8	31.75	M6 x 1.0P
261.651.08.110	HLB12 x SFC8 - 110	165	110	107	36	8	14	30.8	31.75	M6 x 1.0P
261.651.10.045	HLB12 x SFC10 - 45	100	45	40.1	42	10	16	22.3	31.75	M8 x 1.25P
261.651.10.080	HLB12 x SFC10 - 80	135	80	76	42	10	16	27.9	31.75	M8 x 1.25P
261.651.10.110	HLB12 x SFC10 - 110	165	110	100	42	10	16	31.75	31.75	M8 x 1.25P
262.651.03.045	HLB20 x SFC3 - 45	113	45	40.1	18	3	9	15.3	38.1	-
262.651.03.080	HLB20 x SFC3 - 80	148	80	75.1	18	3	9	20.8	38.1	-
262.651.03.110	HLB20 x SFC3 - 110	178	110	105.1	18	3	9	25.5	38.1	-
262.651.04.045	HLB20 x SFC4 - 45	113	45	40.1	20	4	10	16.3	38.1	-
262.651.04.080	HLB20 x SFC4 - 80	148	80	75.1	20	4	10	21.8	38.1	-
262.651.04.110	HLB20 x SFC4 - 110	178	110	105.1	20	4	10	26.5	38.1	-
262.651.05.045	HLB20 x SFC5 - 45	113	45	40.1	20	5	11	17.3	38.1	M4 x 0.7P
262.651.05.080	HLB20 x SFC5 - 80	148	80	75.1	20	5	11	22.8	38.1	M4 x 0.7P
262.651.05.110	HLB20 x SFC5 - 110	178	110	105.1	20	5	11	27.5	38.1	M4 x 0.7P
262.651.06.045	HLB20 x SFC6 - 45	113	45	40.1	36	6	12	18.3	38.1	M5 x 0.8P
262.651.06.080	HLB20 x SFC6 - 80	148	80	75.1	36	6	12	23.8	38.1	M5 x 0.8P
262.651.06.110	HLB20 x SFC6 - 110	178	110	105.1	36	6	12	28.5	38.1	M5 x 0.8P
262.651.08.045	HLB20 x SFC8 - 45	113	45	40.1	36	8	14	20.3	38.1	M6 x 1.0P
262.651.08.080	HLB20 x SFC8 - 80	148	80	75.1	36	8	14	25.8	38.1	M6 x 1.0P
262.651.08.110	HLB20 x SFC8 - 110	178	110	105.1	36	8	14	30.5	38.1	M6 x 1.0P
262.651.10.045	HLB20 x SFC10 - 45	113	45	40.1	42	10	16	22.3	38.1	M8 x 1.25P
262.651.10.080	HLB20 x SFC10 - 80	148	80	75.1	42	10	16	27.8	38.1	M8 x 1.25P
262.651.10.110	HLB20 x SFC10 - 110	178	110	105.1	42	10	16	32.5	38.1	M8 x 1.25P
262.651.12.045	HLB20 x SFC12 - 45	113	45	40.1	47	12	18	24.3	38.1	M10 x 1.5P
262.651.12.080	HLB20 x SFC12 - 80	148	80	75.1	47	12	18	29.8	38.1	M10 x 1.5P
262.651.12.110	HLB20 x SFC12 - 110	178	110	106	47	12	18	34.6	38.1	M10 x 1.5P

HLB / SFC COLLET TYPE SHRINK FIT CHUCK

HLB / SFC 筒夾式熱膨脹刀桿

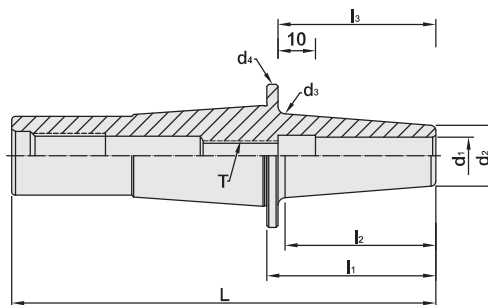

MODEL NO.	TYPE	L	l ₁	l ₂	l ₃	d ₁	d ₂	d ₃	d ₄	T
263.651.03.045	HLB25 x SFC3 - 45	123	45	40.1	18	3	9	15.3	44.45	-
263.651.03.080	HLB25 x SFC3 - 80	158	80	75.1	18	3	9	20.8	44.45	-
263.651.03.110	HLB25 x SFC3 - 110	188	110	105.1	18	3	9	25.5	44.45	-
263.651.04.045	HLB25 x SFC4 - 45	123	45	40.1	20	4	10	16.3	44.45	-
263.651.04.080	HLB25 x SFC4 - 80	158	80	75.1	20	4	10	21.8	44.45	-
263.651.04.110	HLB25 x SFC4 - 110	188	110	105.1	20	4	10	26.5	44.45	-
263.651.05.045	HLB25 x SFC5 - 45	123	45	40.1	20	5	11	17.3	44.45	M4 x 0.7P
263.651.05.080	HLB25 x SFC5 - 80	158	80	75.1	20	5	11	22.8	44.45	M4 x 0.7P
263.651.05.110	HLB25 x SFC5 - 110	188	110	105.1	20	5	11	27.5	44.45	M4 x 0.7P
263.651.06.045	HLB25 x SFC6 - 45	123	45	40.1	36	6	12	18.3	44.45	M5 x 0.8P
263.651.06.080	HLB25 x SFC6 - 80	158	80	75.1	36	6	12	23.8	44.45	M5 x 0.8P
263.651.06.110	HLB25 x SFC6 - 110	188	110	105.1	36	6	12	28.5	44.45	M5 x 0.8P
263.651.08.045	HLB25 x SFC8 - 45	123	45	40.1	36	8	14	20.3	44.45	M6 x 1.0P
263.651.08.080	HLB25 x SFC8 - 80	158	80	75.1	36	8	14	25.8	44.45	M6 x 1.0P
263.651.08.110	HLB25 x SFC8 - 110	188	110	105.1	36	8	14	30.5	44.45	M6 x 1.0P
263.651.10.045	HLB25 x SFC10 - 45	123	45	40.1	42	10	16	22.3	44.45	M8 x 1.25P
263.651.10.080	HLB25 x SFC10 - 80	158	80	75.1	42	10	16	27.8	44.45	M8 x 1.25P
263.651.10.110	HLB25 x SFC10 - 110	188	110	105.1	42	10	16	32.5	44.45	M8 x 1.25P
263.651.12.045	HLB25 x SFC12 - 45	123	45	40.1	47	12	18	24.3	44.45	M10 x 1.5P
263.651.12.080	HLB25 x SFC12 - 80	158	80	75.1	47	12	18	29.8	44.45	M10 x 1.5P
263.651.12.110	HLB25 x SFC12 - 110	188	110	105.1	47	12	18	34.5	44.45	M10 x 1.5P
263.651.14.045	HLB25 x SFC14 - 45	123	45	40.1	47	14	20	26.3	44.45	M10 x 1.5P
263.651.14.080	HLB25 x SFC14 - 80	158	80	75.1	47	14	20	31.8	44.45	M10 x 1.5P
263.651.14.110	HLB25 x SFC14 - 110	188	110	105.1	47	14	20	36.5	44.45	M10 x 1.5P
263.651.16.050	HLB25 x SFC16 - 50	128	50	45.1	50	16	22	29.1	44.45	M12 x 1.75P
263.651.16.080	HLB25 x SFC16 - 80	158	80	75.1	50	16	22	33.8	44.45	M12 x 1.75P
263.651.16.110	HLB25 x SFC16 - 110	188	110	105.1	50	16	22	38.5	44.45	M12 x 1.75P
263.651.18.050	HLB25 x SFC18 - 50	128	50	45.1	50	18	24	31.1	44.45	M12 x 1.75P
263.651.18.080	HLB25 x SFC18 - 80	158	80	75.1	50	18	24	35.8	44.45	M12 x 1.75P
263.651.18.110	HLB25 x SFC18 - 110	188	110	106	50	18	24	40.6	44.45	M12 x 1.75P
263.651.20.050	HLB25 x SFC20 - 50	128	50	45.1	52	20	26	33.1	44.45	M16 x 2.0P
263.651.20.080	HLB25 x SFC20 - 80	158	80	75.1	52	20	26	37.8	44.45	M16 x 2.0P
263.651.20.110	HLB25 x SFC20 - 110	188	110	106.6	52	20	26	42.7	44.45	M16 x 2.0P

HLB / MAP FACE CONTACT TYPE 90° END MILL CUTTER

HLB / MAP 端面緊貼型 90° 刀具

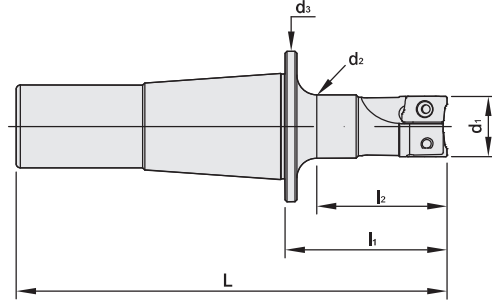

T W PAT NO. M488361

MODEL NO.	TYPE	L	l ₁	l ₂	d ₁	d ₂	d ₃	TEETH	INSERT	WEIGHT (KGS)
261.467.10.040	HLB12 x MAP10 - 40 - 1T	95	40	32	10	12	31.75	1	AP.1135	0.10
261.467.12.040	HLB12 x MAP12 - 40 - 1T	95	40	32	12	11	31.75	1	AP.1135	0.11
261.468.16.040	HLB12 x MAP16 - 40 - 2T	95	40	34	16	16	31.75	2	AP.1135	0.13
262.467.10.040	HLB20 x MAP10 - 40 - 1T	108	40	32	10	12	38.1	1	AP.1135	0.22
262.467.12.040	HLB20 x MAP12 - 40 - 1T	108	40	32	12	11	38.1	1	AP.1135	0.23
262.468.16.040	HLB20 x MAP16 - 40 - 2T	108	40	34	16	16	38.1	2	AP.1135	0.25
262.468.20.040	HLB20 x MAP20 - 40 - 2T	108	40	34	20	16.8	38.1	2	AP.1135	0.28
262.469.25.040	HLB20 x MAP25 - 40 - 3T	108	40	34	25	23.5	38.1	3	AP.1135	0.32
262.470.25.040	HLB20 x MAP25 - 40 - 4T	108	40	34	25	23.5	38.1	4	AP.1135	0.32
262.468.32.040	HLB20 x MAP32 - 40 - 2T	108	40	35	32	31.45	38.1	2	AP.1604	0.38
262.469.32.040	HLB20 x MAP32 - 40 - 3T	108	40	35	32	31.45	38.1	3	AP.1604	0.41
263.467.10.040	HLB25 x MAP10 - 40 - 1T	118	40	32	10	12	44.45	1	AP.1135	0.31
263.467.12.040	HLB25 x MAP12 - 40 - 1T	118	40	32	12	11	44.45	1	AP.1135	0.31
263.468.16.040	HLB25 x MAP16 - 40 - 2T	118	40	34	16	16	44.45	2	AP.1135	0.33
263.468.20.040	HLB25 x MAP20 - 40 - 2T	118	40	34	20	16.8	44.45	2	AP.1135	0.36
263.469.25.040	HLB25 x MAP25 - 40 - 3T	118	40	34	25	23.5	44.45	3	AP.1135	0.40
263.470.25.040	HLB25 x MAP25 - 40 - 4T	118	40	34	25	23.5	44.45	4	AP.1135	0.40
263.468.32.040	HLB25 x MAP32 - 40 - 2T	118	40	34	32	31.45	44.45	2	AP.1604	0.46
263.469.32.040	HLB25 x MAP32 - 40 - 3T	118	40	34	32	31.45	44.45	3	AP.1604	0.49

ACCESSORIES

INSERT	SCREW	WRENCH
AP.1135	M2.5-6.45-3.7-60	T8
AP.1604	M4-10-5.7-60	T15

Product information:

- ▶ Inserts are optional accessories. Need to be purchased additionally.

HLB / CMAP FACE CONTACT TYPE 90° END MILL CUTTER

HLB / CMAP 端面緊貼型 90° 刀具

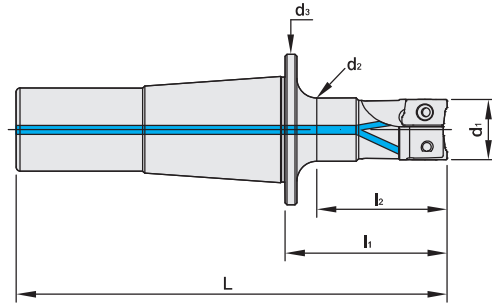

T W PAT NO. M488361

MODEL NO.	TYPE	L	l ₁	l ₂	d ₁	d ₂	d ₃	TEETH	INSERT	WEIGHT (KGS)
261.467C.10.040	HLB12 x CMAP10 - 40 - 1T	95	40	32	10	12	31.75	1	AP.1135	0.10
261.467C.12.040	HLB12 x CMAP12 - 40 - 1T	95	40	32	12	11	31.75	1	AP.1135	0.11
261.468C.16.040	HLB12 x CMAP16 - 40 - 2T	95	40	34	16	16	31.75	2	AP.1135	0.13
262.467C.10.040	HLB20 x CMAP10 - 40 - 1T	108	40	32	10	12	38.1	1	AP.1135	0.22
262.467C.12.040	HLB20 x CMAP12 - 40 - 1T	108	40	32	12	11	38.1	1	AP.1135	0.23
262.468C.16.040	HLB20 x CMAP16 - 40 - 2T	108	40	34	16	16	38.1	2	AP.1135	0.25
262.468C.20.040	HLB20 x CMAP20 - 40 - 2T	108	40	34	20	16.8	38.1	2	AP.1135	0.28
262.469C.25.040	HLB20 x CMAP25 - 40 - 3T	108	40	34	25	23.5	38.1	3	AP.1135	0.32
262.470C.25.040	HLB20 x CMAP25 - 40 - 4T	108	40	34	25	23.5	38.1	4	AP.1135	0.32
262.468C.32.040	HLB20 x CMAP32 - 40 - 2T	108	40	35	32	31.45	38.1	2	AP.1604	0.41
262.469C.32.040	HLB20 x CMAP32 - 40 - 3T	108	40	35	32	31.45	38.1	3	AP.1604	0.41
263.467C.10.040	HLB25 x CMAP10 - 40 - 1T	118	40	32	10	12	44.45	1	AP.1135	0.31
263.467C.12.040	HLB25 x CMAP12 - 40 - 1T	118	40	32	12	11	44.45	1	AP.1135	0.32
263.468C.16.040	HLB25 x CMAP16 - 40 - 2T	118	40	34	16	16	44.45	2	AP.1135	0.34
263.468C.20.040	HLB25 x CMAP20 - 40 - 2T	118	40	34	20	16.8	44.45	2	AP.1135	0.36
263.469C.25.040	HLB25 x CMAP25 - 40 - 3T	118	40	34	25	23.5	44.45	3	AP.1135	0.41
263.470C.25.040	HLB25 x CMAP25 - 40 - 4T	118	40	34	25	23.5	44.45	4	AP.1135	0.41
263.468C.32.040	HLB25 x CMAP32 - 40 - 2T	118	40	34	32	31.45	44.45	2	AP.1604	0.50
263.469C.32.040	HLB25 x CMAP32 - 40 - 3T	118	40	34	32	31.45	44.45	3	AP.1604	0.50

ACCESSORIES

INSERT	SCREW	WRENCH
AP.1135	M2.5-6.45-3.7-60	T8
AP.1604	M4-10-5.7-60	T15

Product information:

- ▶ Inserts are optional accessories. Need to be purchased additionally.

HLB FACE CONTACT TYPE BALL NOSE FINISH END MILL CUTTER

3°

HLB / BFC 端面緊貼型圓鼻刀具

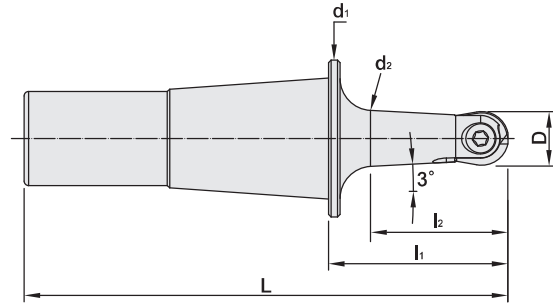

T W PAT NO. M488361

MODEL NO.	TYPE	L	l ₁	l ₂	D	d ₁	d ₂	INSERT	WEIGHT (KGS)
261.35.R4.040	HLB12 x BFC4 - 40	95	40	29.4	8	31.75	9.7	P3204-D08	0.10
261.35.R5.040	HLB12 x BFC5 - 40	95	40	29.4	10	31.75	11.6	P3204-D10	0.10
261.35.R6.040	HLB12 x BFC6 - 40	95	40	29.6	12	31.75	12.3	P3204-D12	0.11
261.35.R8.040	HLB12 x BFC8 - 40	95	40	29.4	16	31.75	16.4	P3204-D16	0.13
261.35.R10.040	HLB12 x BFC10 - 40	95	40	32.3	20	31.75	20.4	P3204-D20	0.15
261.35.R12.5.040	HLB12 x BFC12.5 - 40	95	40	36	25	31.75	25.6	P3204-D25	0.18
262.35.R4.040	HLB20 x BFC4 - 40	108	40	29.4	8	38.1	9.7	P3204-D08	0.22
262.35.R5.040	HLB20 x BFC5 - 40	108	40	29.4	10	38.1	11.6	P3204-D10	0.23
262.35.R6.040	HLB20 x BFC6 - 40	108	40	29.6	12	38.1	12.3	P3204-D12	0.24
262.35.R8.040	HLB20 x BFC8 - 40	108	40	29.4	16	38.1	16.4	P3204-D16	0.25
262.35.R10.040	HLB20 x BFC10 - 40	108	40	32.3	20	38.1	20.4	P3204-D20	0.27
262.35.R12.5.040	HLB20 x BFC12.5 - 40	108	40	32.3	25	38.1	25.2	P3204-D25	0.30
263.35.R4.040	HLB25 x BFC4 - 40	118	40	29.5	8	44.45	9.0	P3204-D08	0.31
263.35.R5.040	HLB25 x BFC5 - 40	118	40	29.5	10	44.45	10.7	P3204-D10	0.32
263.35.R6.040	HLB25 x BFC6 - 40	118	40	29	12	44.45	12.3	P3204-D12	0.33
263.35.R8.040	HLB25 x BFC8 - 40	118	40	29.5	16	44.45	15.3	P3204-D16	0.34
263.35.R10.040	HLB25 x BFC10 - 40	118	40	32.3	20	44.45	18.9	P3204-D20	0.36
263.35.R12.5.040	HLB25 x BFC12.5 - 40	118	40	32.3	25	44.45	23.5	P3204-D25	0.39

ACCESSORIES

INSERT	SCREW	WRENCH
P3204-D08	BFC-4R	T8
P3204-D10	BFC-5R	T15
P3204-D12	BFC-6R	T20
P3204-D16	BFC-8R	T20
P3204-D20	BFC-10R	T20
P3204-D25	BFC-12.5R	T30

Product information:

- ▶ Inserts are optional accessories. Need to be purchased additionally.

HLB FACE CONTACT TYPE BALL NOSE FINISH END MILL CUTTER

4.5°

HLB / BFC 端面緊貼型圓鼻刀具

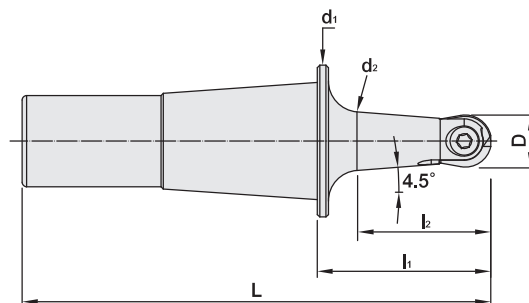

T W PAT NO. M488361

MODEL NO.	TYPE	L	l ₁	l ₂	D	d ₁	d ₂	INSERT	WEIGHT (KGS)
261.35.R4.040D	HLB12 x BFC4 - 40D	95	40	29.4	8	31.75	11.1	P3204-D08	0.10
261.35.R5.040D	HLB12 x BFC5 - 40D	95	40	29.6	10	31.75	12.9	P3204-D10	0.10
261.35.R6.040D	HLB12 x BFC6 - 40D	95	40	29.6	12	31.75	13.3	P3204-D12	0.12
261.35.R8.040D	HLB12 x BFC8 - 40D	95	40	29.6	16	31.75	17.5	P3204-D16	0.14
261.35.R10.040D	HLB12 x BFC10 - 40D	95	40	32.4	20	31.75	21.7	P3204-D20	0.16
261.35.R12.5.040D	HLB12 x BFC12.5 - 40D	95	40	36.8	25	31.75	26.9	P3204-D25	0.19
262.35.R4.040D	HLB20 x BFC4 - 40D	108	40	29.4	8	38.1	11.1	P3204-D08	0.23
262.35.R5.040D	HLB20 x BFC5 - 40D	108	40	29.6	10	38.1	12.9	P3204-D10	0.24
262.35.R6.040D	HLB20 x BFC6 - 40D	108	40	29.6	12	38.1	13.3	P3204-D12	0.25
262.35.R8.040D	HLB20 x BFC8 - 40D	108	40	29.6	16	38.1	17.5	P3204-D16	0.27
262.35.R10.040D	HLB20 x BFC10 - 40D	108	40	32.4	20	38.1	21.7	P3204-D20	0.30
262.35.R12.5.040D	HLB20 x BFC12.5 - 40D	108	40	32.4	25	38.1	26.3	P3204-D25	0.34
263.35.R4.040D	HLB25 x BFC4 - 40D	118	40	29.5	8	44.45	10.0	P3204-D08	0.31
263.35.R5.040D	HLB25 x BFC5 - 40D	118	40	29	10	44.45	11.8	P3204-D10	0.32
263.35.R6.040D	HLB25 x BFC6 - 40D	118	40	29.6	12	44.45	13.3	P3204-D12	0.33
263.35.R8.040D	HLB25 x BFC8 - 40D	118	40	29.6	16	44.45	16.1	P3204-D16	0.35
263.35.R10.040D	HLB25 x BFC10 - 40D	118	40	32.4	20	44.45	19.5	P3204-D20	0.38
263.35.R12.5.040D	HLB25 x BFC12.5 - 40D	118	40	32.4	25	44.45	23.9	P3204-D25	0.42

ACCESSORIES

INSERT	SCREW	WRENCH
P3204-D08	BFC-4R	T8
P3204-D10	BFC-5R	T15
P3204-D12	BFC-6R	T20
P3204-D16	BFC-8R	T20
P3204-D20	BFC-10R	T20
P3204-D25	BFC-12.5R	T30

Product information:

- ▶ Inserts are optional accessories. Need to be purchased additionally.

HLB / PMB FACE CONTACT TYPE FINISH BORING HEAD

HLB / PMB 端面緊貼型精糖頭

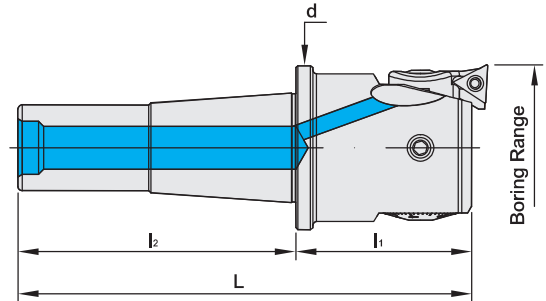

T W PAT NO. M488361

MODEL NO.	TYPE	INSERT SEAT	INSERT		BORING RANGE	L	l ₁	l ₂	d	WEIGHT (KGS)
262.657.25.068	HLB20 x PMB25 - 68	SIC25 - 1	TB..06	TP..08	25 ~ 33	138	70	68	38.1	0.39
		SIC25 - 2	TB..06	TP..08	32 ~ 40	138	70	68	38.1	0.39
		SIC25 - 3	TB..06	TP..08	39 ~ 47	138	70	68	38.1	0.39
262.657.32.084	HLB20 x PMB32 - 84	SIC32 - 1	TB..06	TP..08	32 ~ 42	151	83	84	38.1	0.59
		SIC32 - 2	TB..06	TP..08	41 ~ 51	151	83	84	38.1	0.59
		SIC32 - 3	TB..06	TP..08	50 ~ 60	151	83	84	38.1	0.59
262.657.41.090	HLB20 x PMB41 - 90	SIC41 - 1	TP..09	TC..11	41 ~ 54	157	89	90	38.1	0.85
		SIC41 - 2	TP..09	TC..11	50 ~ 63	157	89	90	38.1	0.85
		SIC41 - 3	TP..09	TC..11	61 ~ 74	157	89	90	38.1	0.85
263.657.25.068	HLB25 x PMB25 - 68	SIC25 - 1	TB..06	TP..08	25 ~ 33	148	70	68	44.45	0.48
		SIC25 - 2	TB..06	TP..08	32 ~ 40	148	70	68	44.45	0.48
		SIC25 - 3	TB..06	TP..08	39 ~ 47	148	70	68	44.45	0.48
263.657.32.084	HLB25 x PMB32 - 84	SIC32 - 1	TB..06	TP..08	32 ~ 42	161	83	84	44.45	0.67
		SIC32 - 2	TB..06	TP..08	41 ~ 51	161	83	84	44.45	0.67
		SIC32 - 3	TB..06	TP..08	50 ~ 60	161	83	84	44.45	0.67
263.657.41.090	HLB25 x PMB41 - 90	SIC41 - 1	TP..09	TC..11	41 ~ 54	168	90	90	44.45	0.93
		SIC41 - 2	TP..09	TC..11	50 ~ 63	168	90	90	44.45	0.93
		SIC41 - 3	TP..09	TC..11	61 ~ 74	168	90	90	44.45	0.93

TYPES FOR INSERT SEAT

TYPE	DRAWING	SUITABLE FINISH BORING HEAD	TYPE	DRAWING	SUITABLE FINISH BORING HEAD	STANDARD INSERT SEAT	OPTIONAL INSERT SEAT	
SIC32 - 1		PMB32	SIC32 - 1E		PMB32	SIC32 - 1	SIC32 - 2	SIC32 - 3
SIC32 - 2		PMB32	SIC32 - 2E		PMB32	φ 32 ~ φ 42	φ 41 ~ φ 51	φ 50 ~ φ 60
SIC32 - 3		PMB32	SIC32 - 3E		PMB32			
SIC41 - 1		PMB41	SIC41 - 1E		PMB41			
SIC41 - 2		PMB41	SIC41 - 2E		PMB41			
SIC41 - 3		PMB41	SIC41 - 3E		PMB41			
SIC53 - 1		PMB53	SIC53 - 1E		PMB53			
SIC53 - 2		PMB53	SIC53 - 2E		PMB53			
SIC53 - 3		PMB53	SIC53 - 3E		PMB53			
SIC68 - 1		PMB68	SIC68 - 1E		PMB68			
SIC68 - 2		PMB68	SIC68 - 2E		PMB68			
SIC68 - 3		PMB68	SIC68 - 3E		PMB68			

ACCESSORIES

INSERT	SCREW	WRENCH	INSERT	SCREW	WRENCH
TB..0601	M2-5.0-2.7-60	T6	TP..0902	M2.5-6.0-3.5-60	T8
TP..0802	M2-5.0-2.7-60	T6	TC..1102	M2.5-6.0-3.5-60	T8

Product information:

- ▶ The body of PMB Finish Boring Head is always designed to have coolant outlet.
- ▶ There are 3 types of insert seats and the boring range of insert seat can be enlarged by exchanging another insert seat.
- ▶ Inserts are optional accessories. Need to be purchased additionally.

HLB / PCK FACE CONTACT TYPE ROUGH BORING HEAD

HLB / PCK 端面緊貼型粗搪頭



T W PAT NO. M488361

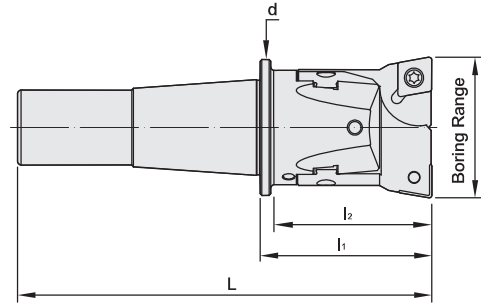

MODEL NO.	TYPE	BORING RANGE		L	l ₁	l ₂	d	INSERT	WEIGHT (KGS)
		MIN.	MAX.						
262.650.24.068	HLB20 x PCK2430 - 68	24	30	141	73	68	38.1	CC..0602	0.34
262.650.29.084	HLB20 x PCK2940 - 84	29	40	157	89	84	38.1	CC..09T3	0.47
262.650.39.090	HLB20 x PCK3950 - 90	39	50	163	95	90	38.1	CC..09T3	0.51
263.650.24.068	HLB25 x PCK2430 - 68	24	30	151	73	68	44.45	CC..0602	0.43
263.650.29.084	HLB25 x PCK2940 - 84	29	40	167	89	84	44.45	CC..09T3	0.56
263.650.39.090	HLB25 x PCK3950 - 90	39	50	173	95	90	44.45	CC..09T3	0.59
263.650.49.090	HLB25 x PCK4965 - 90	49	65	171.5	93.5	90	44.45	CC..1204	0.62

ACCESSORIES

INSERT	SCREW	WRENCH
CC..0602	M2.5-6.45-3.7	T8
CC..09T3	M4-10-5.7-4.3	T15
CC..1204	M5-11-7.5-60	T20

Product information:

- ▶ Inserts are optional accessories. Need to be purchased additionally.

HLB / MCK FACE CONTACT TYPE BORING HEAD SHANK

HLB / MCK 端面緊貼型搪孔夾頭柄

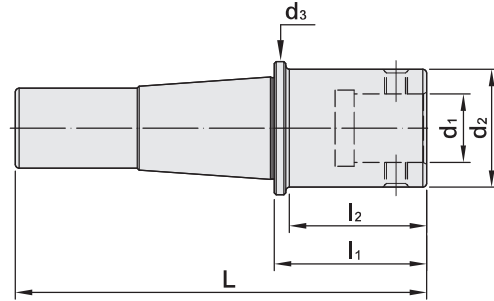

T W PAT NO. M488361

MODEL NO.	TYPE	L	l ₁	l ₂	d ₁	d ₂	d ₃	T	WEIGHT (KGS)
262.487.01.040	HLB20 x MCK1 - 40	108	40	34	11	19	38.1	M4 x 0.5P	0.26
262.487.02.040	HLB20 x MCK2 - 40	108	40	34	14	23.5	38.1	M5 x 0.5P	0.30
262.487.03.040	HLB20 x MCK3 - 40	108	40	30	18	31	38.1	M6 x 0.75P	0.36
263.487.01.040	HLB25 x MCK1 - 40	118	40	34	11	19	44.45	M4 x 0.5P	0.34
263.487.02.040	HLB25 x MCK2 - 40	118	40	34	14	23.5	44.45	M5 x 0.5P	0.38
263.487.03.040	HLB25 x MCK3 - 40	118	40	30	18	31	44.45	M6 x 0.75P	0.44