

BORING CATEGORY

SMU BLACK KNIGHT FINISH BORING HEAD	M-2
PSC / PCK ROUGH BORING HEAD	M-3
ROUGHING TWIN ADJUSTMENT BORING HEAD	M-3
PSC / PBJ FINISH BORING HEAD	M-4
SBJ BORING HEAD FOR FINISHING	M-4
SBE EXTENDED BORING INSERT SEAT	M-5
SLEEVE FOR TUNGSTEN STEEL TOOL HOLDER	M-6
ANTI-VIBRANT TUNGSTEN STEEL TOOL HOLDER	M-6
THROW - AWAY BORING HEAD	M-7
BORING CUTTER	M-8
BORING HEAD SHANK SET	M-9
PRECISION BORING HEAD	M-10
PSC / PMB FINISH BORING HEAD	M-11
SUPER MICRON EXCHANGEABLE FINISH BORING HEAD	M-12~13
SRW ROUGHING BORING HEAD	M-14~15
SMB SUPER MICRON EXCHANGEABLE FINISH BORING HEAD	M-16~17
SIMPLIFIED TOOL PRESETTERFOR SRW&SMB BORING HEAD	M-18
BT / SCK BORING HEAD SHANK	M-19~21
BT / MCK BORING HEAD SHANK	M-22~26
CAT / SCK BORING HEAD SHANK	M-27
CAT / MCK BORING HEAD SHANK	M-28
DAT / SCK BORING HEAD SHANK	M-29
DAT / MCK BORING HEAD SHANK	M-30
SBT / SCK BORING HEAD SHANK	M-31~33
SBT / MCK BORING HEAD SHANK	M-34~37
SCAT / SCK BORING HEAD SHANK	M-38
SCAT / MCK BORING HEAD SHANK	M-39
SDAT / SCK BORING HEAD SHANK	M-40
SDAT / MCK BORING HEAD SHANK	M-41
HSK / SCK BORING HEAD SHANK	M-42~43
HSK / MCK BORING HEAD SHANK	M-44~45
PSC / SCK BORING HEAD SHANK	M-46
PSC / MCK BORING HEAD SHANK	M-47~48
STRAIGHT SHANK SCK BORING HEAD SHANK	M-49
STRAIGHT SHANK MCK BORING HEAD SHANK	M-50
EXTENSION SPACER	M-51
PRECISION BT BORING HEAD SHANK	M-52~53
NBH BORING HEAD	M-53
PRECISION DAT BORING HEAD SHANK	M-54
PRECISION BORING HEAD SHANK	M-54
PRECISION BORING HEAD SHANK SET	M-55
BORING HEAD FULL SET	M-56
BYB BORING HEAD	M-57
SCK / BYB FINISH BORING HEAD	M-57
BT / BYB BORING HEAD SHANK	M-58
BT SQUARE CUTTER BORING BAR	M-59~60
THROW AWAY BORING CUTTER	M-61~62

SMU BLACK KNIGHT FINISH BORING HEAD

SMU 黑武士精搪頭

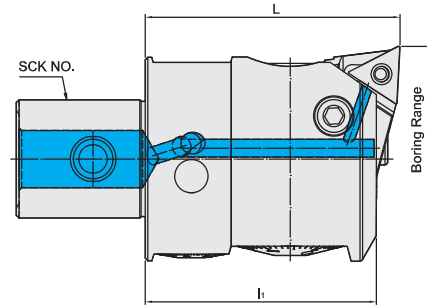

T W PAT NO. M500637
D E PAT NO. Nr.202015103584

MODEL NO.	TYPE	SCK NO.	BORING AND PROCESSING AT FRONT			INSERT	SCREW	WRENCH	WEIGHT (KGS)
			BORING RANGE	L	I ₁				
19590	SMU32	SCK3	32 ~ 42	40	37	TC..1102	M2.5-6.0-3.5-60	T8	0.20
19591	SMU41	SCK4	41 ~ 54	47	43	TC..1102	M2.5-6.0-3.5-60	T8	0.40
19592	SMU53	SCK5	53 ~ 70	57	53	TC..1102	M2.5-6.0-3.5-60	T8	0.80
19593	SMU68	SCK6	68 ~ 100	71	67	TC..1102	M2.5-6.0-3.5-60	T8	1.65

Features:

- ▶ Micrometric adjustment on the diameters.
- ▶ Exchangeable insert seat is easy and convenient for replacement.
- ▶ Balancing adjustments can be made by users.
- ▶ Special surface structure to absorb shock and drain external water away.
- ▶ Surface treatment of matte finish for anti-glare and acid corrosion prevention.
- ▶ Available with SCK, MCK and CK connection.
- ▶ SMU is designed to have a coolant hole, which can remove the metal chips effectively and it's durable for coolant pressure up to 1,300 PSI.

Product information:

- ▶ Inserts are optional accessories. Needs to be purchased additionally.

PSC / PCK ROUGH BORING HEAD

ONE-PIECE TYPE

PSC / PCK 可調整式雙刃粗搪孔頭 [一體式]



台灣精品 2015
TAIWAN EXCELLENCE

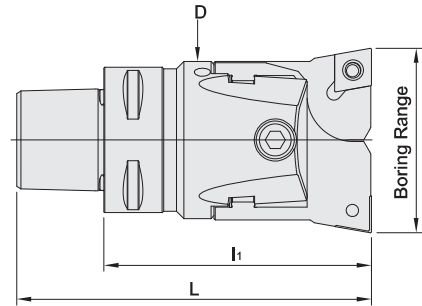

MODEL NO.	TYPE	BORING RANGE		L	l ₁	D	INSERT	SCREW	WRENCH	WEIGHT (KGS)
		MIN.	MAX.							
140.650.39.080	PSC32 x PCK3950 - 80	39	50	99	80	32	CC..09T3	M4 - 10 - 5.7 - 60	T15	0.49
141.650.49.082	PSC40 x PCK4965 - 82	49	65	106	82	42	CC..1204	M5 - 11 - 7.5 - 60	T20	0.49
142.650.63.092	PSC50 x PCK6382 - 92	63	82	122	92	54	CC..1204	M5 - 11 - 7.5 - 60	T20	0.70
143.650.80.140	PSC63 x PCK80102 - 140	80	102	178	140	68	CC..1204	M5 - 9.2 - 7.6 - 60	T20	3.60

Product information:

- ▶ With the design of PSC one piece boring head to lock with adapters, the total length is shorter than old design and the rigidity and stability are improved!
- ▶ Inserts are optional accessories. Needs to be purchased additionally.



For adapters, please refer to

Adapter	Page	Adapter	Page
BT	▶ A-56	SCAT	▶ E-19
CAT	▶ B-25	SDAT	▶ F-20
DAT	▶ C-33	HSK	▶ G-32
SBT	▶ D-49	PSC	▶ H-45~46

ROUGHING TWIN ADJUSTMENT BORING HEAD

SCK 可調整式雙刃粗搪孔頭



台灣精品 2008
TAIWAN EXCELLENCE



T W PAT NO. M280258
T W PAT NO. M337434
J P PAT NO. 3141963
E S PAT NO. 1067716
C H PAT NO. ZL200820102789.1

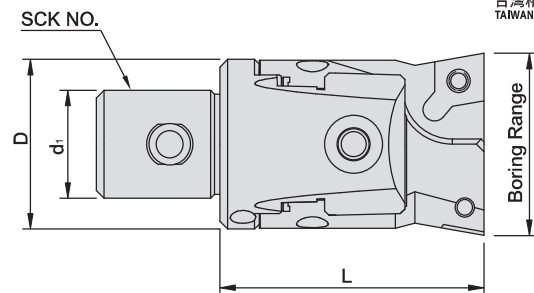

MODEL NO.	TYPE	ASSEMBLE TOOL HOLDER	Boring Range		d ₁	L	D	INSERT	SCREW	WRENCH	WEIGHT (KGS)
			MIN.	MAX.							
17602	SCK2430 - C	SCK2	24	30	14	34	22	CC..0602	M2.5-6.45-3.7	T8	0.19
17604	SCK2940 - C	SCK2	29	40	14	42	27	CC..09T3	M4-10-5.7-60	T15	0.19
17606	SCK3950 - C	SCK3	39	50	18	45	32	CC..09T3	M4-10-5.7-60	T15	0.19
17608	SCK4965 - C	SCK4	49	65	22	56	42	CC..1204	M5-11-7.5-60	T20	0.10
17612	SCK6382 - C	SCK5	63	82	28	66	54	CC..1204	M5-11-7.5-60	T20	0.20
17614	SCK80102 - C	SCK6	80	102	36	86	68	CC..1204	M5-9.2-7.6-60	T20	2.30
17616	SCK100125 - C	SCK7	100	125	46	100	85	CC..1204	M5-9.2-7.6-60	T20	4.00
17618	SCK125160 - C	SCK7	125	160	46	100	110	CC..1204	M5-9.2-7.6-60	T20	6.16
17620	SCK160220 - C	SCK7	160	220	46	100	145	CC..1204	M5-11-7.5-60	T20	8.10

Product information:

- ▶ Inserts are optional accessories. Needs to be purchased additionally.



PSC / PBJ FINISH BORING HEAD

ONE-PIECE TYPE

PSC / PBJ 高精密搪孔頭 [一體式]



N R PAT NO. 202015103465
J P PAT NO. 3200982

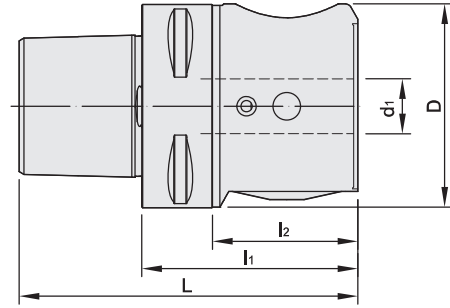

MODEL NO.	TYPE	L	l ₁	l ₂	D	d ₁	WEIGHT (KGS)
141.647.10.48,5	PSC40 x PBJ10 - 48,5	72,5	48,5	28,5	39	10	0,49
142.647.12.056	PSC50 x PBJ12 - 56	86	56	36	50	12	0,91
143.647.16.067	PSC63 x PBJ16 - 67	105	67	45	63,5	16	1,76

For adapters, please refer to

Adapter	Page	Adapter	Page
BT	▶ A-56	SCAT	▶ E-19
CAT	▶ B-25	SDAT	▶ F-20
DAT	▶ C-33	HSK	▶ G-32
SBT	▶ D-49	PSC	▶ H-45~46

Product information:

- ▶ Inserts are optional accessories. Needs to be purchased additionally.



SBJ BORING HEAD FOR FINISHING

SBJ 高精密搪孔頭

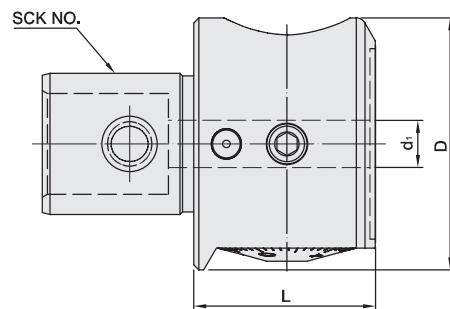

MODEL NO.	TYPE	ASSEMBLE TOOL HOLDER	BORING RANGE	L	D	d ₁	WEIGHT (KGS)
19522	SBJ10	SCK4	8 - 22	28,5	39	10	0,25
19524	SBJ12	SCK5	8 - 32	36	50	12	0,50
19526	SBJ16	SCK6	8 - 50	45	63,5	16	1,00

Product information:

- ▶ Can choose the shank for boring head fit for the machine spindle.
- ▶ Boring head only, not including shank and cutter.

SBE EXTENDED BORING INSERT SEAT

SBE 延伸搪孔刀座



台灣精品 2013
TAIWAN EXCELLENCE



T W PAT NO. M378059
T W PAT NO. M378058
T W PAT NO. M446035
J P PAT NO. 3159159
J P PAT NO. 3183047
C N PAT NO. ZL201220574428.3
D E PAT NO. Nr.20201000051.3
U S PAT NO. US9156091 B2

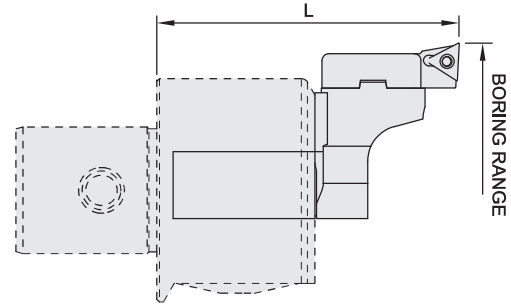

MODEL NO.	TYPE	SBJ NO.	INSERT SEAT	INSERT	BORING AND PROCESSING AT FRONT		WEIGHT (KGS)
					BORING RANGE	L	
158.684.0	SBE - 0	SBJ16	SIC53 - 1	TP09 / TC11	48 - 60	127	0.16
				TP09 / TC11	60 - 72	127	0.16
				TP09 / TC11	72 - 85	127	0.16
158.684.1	SBE - 1	SBJ16	SIC68 - 1	TP09 / TC11	84 - 96	85.5	0.18
				TP09 / TC11	95 - 107	85.5	0.18
158.684.2	SBE - 2	SBJ16	SIC68 - 2	TP09 / TC11	120 - 132	86	0.18
				TP09 / TC11	145 - 157	85.5	0.18
				TP09 / TC11	130 - 142	85.5	0.20
158.684.3	SBE - 3	SBJ16	SIC68 - 2	TP09 / TC11	156 ~ 168	86	0.20
				TP09 / TC11	180 ~ 192	85.5	0.20
				TP09 / TC11	142 ~ 154	85.5	0.24
158.684.4	SBE - 4	SBJ16	SIC68 - 2	TP09 / TC11	168 ~ 180	86	0.24
				TP09 / TC11	192 ~ 202	85.5	0.24

ACCESSORIES

INSERT	SCREW	WRENCH
TP..0902	M2.5-6.0-3.5-60	T8
TC..1102	M3-8.0-4.0-43	T9

TYPES FOR INSERT SEAT:

INSERT	DRAWING	INSERT	DRAWING
SIC53 - 1		SIC53 - 1E	
SIC68 - 1		SIC68 - 1E	
SIC68 - 2		SIC68 - 2E	
SIC68 - 3		SIC68 - 3E	

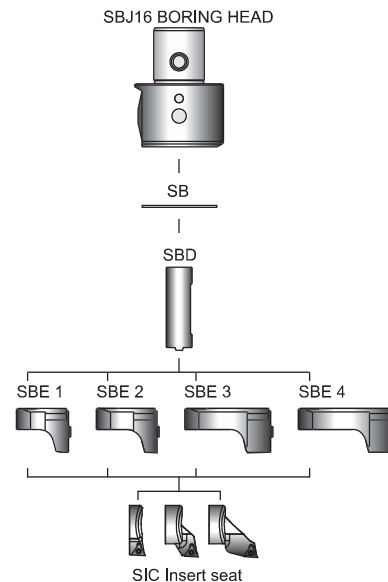

Features:

- ▶ Depending on the range of work piece's diameter, using SBE Extended Boring Insert Seat to enlarge the range of processing and can solve the difficulty of processing different work piece's diameter.
- ▶ To enlarge the range of processing it is easy to operate by only exchanging the insert seat.
- ▶ According to different processing material, operators choose suitable inserts which can increase precision, stability, and have excellent metal chips removal capability.
- ▶ Suitable for SBJ-16(SYIC-19526).

Product information:

- ▶ Tool holders, SBJ Boring head for finishing, and Inserts need to be purchased additionally.



SLEEVE FOR TUNGSTEN STEEL TOOL HOLDER

鎢鋼刀柄專用套筒

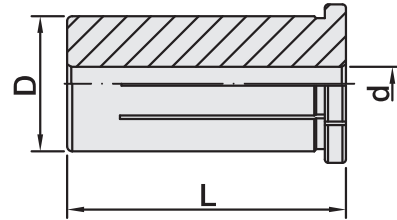

MODEL NO.	TYPE	L	D	d	WEIGHT (KGS)
82790 - 4	SBJ - 10 - 4K	30	10	4	0.01
82790 - 6	SBJ - 10 - 6K	30	10	6	0.01
82790 - 8	SBJ - 10 - 8K	30	10	8	0.01
82791 - 4	SBJ - 12 - 4K	35	12	4	0.01
82791 - 6	SBJ - 12 - 6K	35	12	6	0.01
82791 - 8	SBJ - 12 - 8K	35	12	8	0.01
82791 - 10	SBJ - 12 - 10K	35	12	10	0.01
82792	SBJ - 16 - 8K	37	16	8	0.08
82794	SBJ - 16 - 10K	37	16	10	0.04
82796	SBJ - 16 - 12K	37	16	12	0.02
82798	SBJ - 16 - 14K	37	16	14	0.01

ANTI-VIBRANT TUNGSTEN STEEL TOOL HOLDER

抗震鎢鋼刀柄

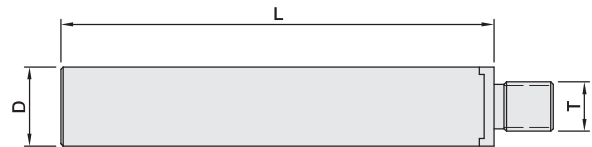

MODEL NO.	TYPE	D	L	T	SUITABLE BORING HEAD	BORING CAPACITY	WEIGHT (KGS)
82712	ST08 - W5 - 100L	8	100	M5	SEB09N	9mm ~ 13mm	0.08
82714	ST10 - W6 - 110L	10	110	M6	SEB12N	12mm ~ 15mm	0.12
82716	ST12 - W6 - 120L	12	120	M6	SEB14N	14mm ~ 17mm	0.21
82718	ST14 - W6 - 160L	14	160	M6	SEB16N	16mm ~ 20mm	0.34
82719	ST16 - W10 - 160L	16	160	M10	SEB18N ~ SEB40N	18mm ~ 42mm	0.45

Features:

- ▶ Boring hole in depth can't exceed 6 times of hole diameter.

THROW - AWAY BORING HEAD

捨棄式搪頭

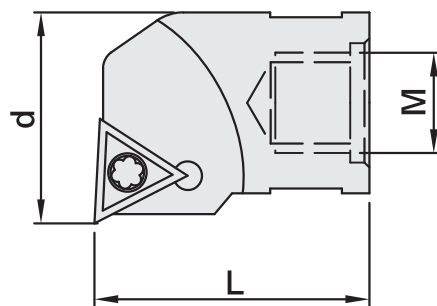

MODEL NO.	TYPE	BORING CAPACITY	d	L	M	INSERTS	SCREW	WRENCH	WEIGHT (KGS)
82732	SEB09N - TP08	9 - 10.5	9	18	M5	TP..0802	M2-5.0-2.7-60	T6	0.02
82732 - 10.5 - TP08	SEB10.5N - TP08	10.5 - 12	10.5	18	M5	TP..0802	M2-5.0-2.7-60	T6	0.02
82733	SEB12N - TP08	12 - 14	12	23	M6	TP..0802	M2-5.0-2.7-60	T6	0.02
82734	SEB14N - TP08	14 - 16	14	23	M6	TP..0802	M2-5.0-2.7-60	T6	0.02
82735	SEB16N - TP08	16 - 18	16	23	M6	TP..0802	M2-5.0-2.7-60	T6	0.03
82736	SEB18N - TP08	18 - 20	18	27	M10	TP..0802	M2-5.0-2.7-60	T6	0.03
82737	SEB20N - TP08	20 - 22	20	27	M10	TP..0802	M2-5.0-2.7-60	T6	0.04
82738	SEB22N - TP08	22 - 24	22	27	M10	TP..0802	M2-5.0-2.7-60	T6	0.04
82739	SEB24N - TP08	24 - 26	24	27	M10	TP..0802	M2-5.0-2.7-60	T6	0.04
82740	SEB26N - TP08	26 - 28	26	27	M10	TP..0802	M2-5.0-2.7-60	T6	0.04
82741	SEB28N - TP08	28 - 30	28	27	M10	TP..0802	M2-5.0-2.7-60	T6	0.04
82742	SEB30N - TP08	30 - 32	30	27	M10	TP..0802	M2-5.0-2.7-60	T6	0.04
82743	SEB32N - TP08	32 - 34	32	27	M10	TP..0802	M2-5.0-2.7-60	T6	0.04
82744	SEB34N - TP08	34 - 36	34	27	M10	TP..0802	M2-5.0-2.7-60	T6	0.05
82745	SEB36N - TP08	36 - 38	36	27	M10	TP..0802	M2-5.0-2.7-60	T6	0.04
82746	SEB38N - TP08	38 - 40	38	27	M10	TP..0802	M2-5.0-2.7-60	T6	0.05
82747	SEB40N - TP08	40 - 42	40	27	M10	TP..0802	M2-5.0-2.7-60	T6	0.05
82748	SEB42N - TP08	42 - 44	42	27	M10	TP..0802	M2-5.0-2.7-60	T6	0.05
82749	SEB44N - TP08	44 - 46	44	27	M10	TP..0802	M2-5.0-2.7-60	T6	0.05
82750	SEB46N - TP08	46 - 48	46	27	M10	TP..0802	M2-5.0-2.7-60	T6	0.05
82751	SEB48N - TP08	48 - 50	48	27	M10	TP..0802	M2-5.0-2.7-60	T6	0.05
82751 - 50 - TP08	SEB50N - TP08	50 - 52	50	27	M10	TP..0802	M2-5.0-2.7-60	T6	0.05
82732 - TB06	SEB09N - 06 - TB06	9 - 10.5	9	18	M5	TB..0601	M2-5.0-2.7-60	T6	0.02
82733 - TB06	SEB12N - 06 - TB06	12 - 14	12	23	M6	TB..0601	M2-5.0-2.7-60	T6	0.02
82734 - TP09	SEB14N - 09 - TP09	14 - 16	14	23	M6	TP..0902	M2.5-6.0-3.5-60	T8	0.02
82735 - TP09	SEB16N - 09 - TP09	16 - 18	16	23	M6	TP..0902	M2.5-6.0-3.5-60	T8	0.03
82736 - TP09	SEB18N - 09 - TP09	18 - 20	18	27	M10	TP..0902	M2.5-6.0-3.5-60	T8	0.03
82737 - TP09	SEB20N - 09 - TP09	20 - 22	20	27	M10	TP..0902	M2.5-6.0-3.5-60	T8	0.04
82738 - TP11	SEB22N - 11 - TP11	22 - 24	22	27	M10	TP..1103	M3-8.0-4.0-43	T9	0.04
82739 - TP11	SEB24N - 11 - TP11	24 - 26	24	27	M10	TP..1103	M3-8.0-4.0-43	T9	0.04
82740 - TP11	SEB26N - 11 - TP11	26 - 28	26	27	M10	TP..1103	M3-8.0-4.0-43	T9	0.04
82741 - TP11	SEB28N - 11 - TP11	28 - 30	28	27	M10	TP..1103	M3-8.0-4.0-43	T9	0.04
82742 - TP11	SEB30N - 11 - TP11	30 - 32	30	27	M10	TP..1103	M3-8.0-4.0-43	T9	0.04
82743 - TP11	SEB32N - 11 - TP11	32 - 34	32	27	M10	TP..1103	M3-8.0-4.0-43	T9	0.04
82744 - TP11	SEB34N - 11 - TP11	34 - 36	34	27	M10	TP..1103	M3-8.0-4.0-43	T9	0.05
82745 - TP11	SEB36N - 11 - TP11	36 - 38	36	27	M10	TP..1103	M3-8.0-4.0-43	T9	0.04
82746 - TP11	SEB38N - 11 - TP11	38 - 40	38	27	M10	TP..1103	M3-8.0-4.0-43	T9	0.05
82747 - TP11	SEB40N - 11 - TP11	40 - 42	40	27	M10	TP..1103	M3-8.0-4.0-43	T9	0.04

Product information:

- ▶ Inserts are optional accessories. Needs to be purchased additionally.



BORING CUTTER

INTERCHANGEABLE

替換式 搪孔刀

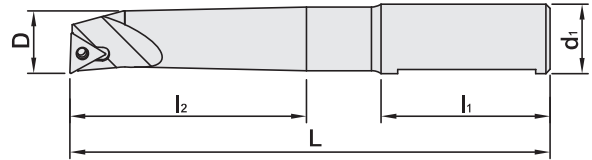

MODEL NO.	TYPE	BORING CAPACITY	D	d ₁	L	l ₁	l ₂	INSERTS	WEIGHT (KGS)
82372	SBJ - 1008 - 24	8 - 11	8	10	58	25	24	TB..0601	0.02
82374	SBJ - 1010 - 30	10 - 13	10	10	64	25	30	TB..0601	0.04
82376	SBJ - 1012 - 36	12 - 17	12	10	70	25	36	TP..0902	0.04
82378	SBJ - 1016 - 48	16 - 21	16	10	78	25	48	TP..0902	0.08
82380	SBJ - 10 4PCS / SET INCLUDE BOX								
82382	SBJ - 1208 - 28	8 - 11	8	12	67	30	28	TB..0601	0.04
82384	SBJ - 1210 - 35	10 - 13	10	12	74	30	35	TB..0601	0.04
82386	SBJ - 1212 - 42	12 - 17	12	12	81	30	42	TP..0902	0.06
82388	SBJ - 1216 - 56	16 - 21	16	12	95	30	56	TP..0902	0.08
82390	SBJ - 1220 - 70	20 - 26	20	12	105	30	70	TP..1103	0.12
82392	SBJ - 12 5PCS / SET INCLUDE BOX								
82752	SBJ - 1608 - 32	8 - 11	8	16	64	32	32	TB..0601	0.06
82754	SBJ - 1610 - 40	10 - 13	10	16	72	32	40	TB..0601	0.07
82756	SBJ - 1612 - 53	12 - 17	12	16	85	32	53	TP..0902	0.08
82758	SBJ - 1616 - 68	16 - 21	16	16	100	32	68	TP..0902	0.12
82760	SBJ - 1620 - 83	20 - 26	20	16	115	32	83	TP..1103	0.16
82762	SBJ - 1625 - 90	25 - 32	25	16	122	32	90	TP..1103	0.25
82764	SBJ - 1630 - 90	30 - 42	30	16	122	32	90	TP..1103	0.30
82766	SBJ - 1640 - 90	40 - 50	40	16	122	32	90	TP..1103	0.40
82768	SBJ - 16 8PCS / SET INCLUDE BOX								
82772	SBJ - 2008 - 32	8 - 11	8	20	64	32	32	TB..0601	0.09
82774	SBJ - 2010 - 40	10 - 13	10	20	72	32	40	TB..0601	0.11
82776	SBJ - 2012 - 53	12 - 17	12	20	85	32	53	TP..0902	0.11
82778	SBJ - 2016 - 68	16 - 21	16	20	100	32	68	TP..0902	0.15
82780	SBJ - 2020 - 83	20 - 26	20	20	115	32	83	TP..1103	0.20
82782	SBJ - 2025 - 96	25 - 135	25	20	128	32	96	TP..1103	0.30
82784	SBJ - 2030 - 115	30 - 140	30	20	147	32	115	TP..1103	0.50
82786	SBJ - 20 - 20L	280	40	20	97	-	-	TP..1103	0.25
82788	SBJ - 20 8PCS / SET INCLUDE BOX								

ACCESSORIES

INSERT	SCREW	WRENCH	INSERT	SCREW	WRENCH
TB..0601	M2-5.0-2.7-60	T6	TP..1103	M3-8.0-4.0-43	T9
TP..0902	M2.5-6.0-3.5-60	T8			

Product information:

- ▶ Inserts are optional accessories. Needs to be purchased additionally.

BORING HEAD SHANK SET

PRECISION

高精度搪孔組

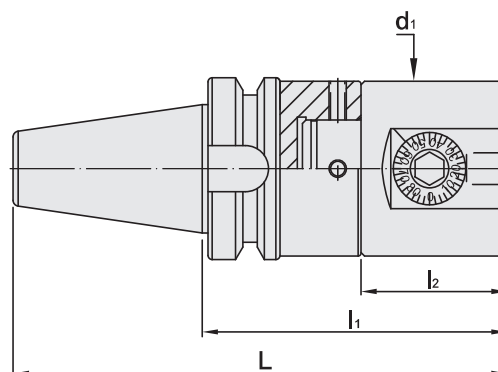

MODEL NO.	TYPE	BORING CAPACITY	L	l ₁	l ₂	d ₁	WEIGHT (KGS)
17697H - SBJ10	BT30 x SBJ10	66.5	136.9	88.5	28.5	39	1.25
17697H - SBJ12	BT30 x SBJ12	84	154.4	106	36	50	1.60
17697	BT30 x SBJ16	115	153.4	105	45	63.5	2.70
17698H - SBJ10	BT40 x SBJ10	71.5	163.9	98.5	28.5	39	1.70
17698H - SBJ12	BT40 x SBJ12	69	161.4	96	36	50	2.30
17698	BT40 x SBJ16	105	165.4	100	45	63.5	2.24
17699H - SBJ10	BT50 x SBJ10	90	229.8	128.5	28.5	39	5.05
17699H - SBJ12	BT50 x SBJ12	58	197.8	96	36	50	5.90
17699	BT50 x SBJ16	148	231.8	130	45	63.5	5.30
45146	DAT30 x SBJ10	58.5	126.3	78.5	28.5	39	1.55
45151	DAT40 x SBJ10	88.5	176.9	108.5	28.5	39	1.55
45153	DAT40 x SBJ12	111	199.4	131	36	50	1.90
45155	DAT40 x SBJ16	105	178.4	110	45	63.5	2.80
45156	DAT50 x SBJ10	118.5	240.25	138.5	28.5	39	3.65
45158	DAT50 x SBJ12	81	202.75	101	36	50	4.00
45160	DAT50 x SBJ16	148	196.75	95	45	63.5	5.30
82588	C32 x SBJ16	8 ~ 50	153	73	45	63.5	2.4
82590	C42 x SBJ16	8 ~ 50	153	73	45	63.5	2.9
82592	R8 x SBJ16	8 ~ 50	180	73	45	63.5	2.5
82594	NT30 x SBJ16	8 ~ 50	141.4	73	45	63.5	2.3
82596	NT40 x SBJ16	8 ~ 50	168.4	75	45	63.5	2.5
82598	NT50 x SBJ16	8 ~ 50	203.8	77	45	63.5	5.0

Product information:

- ▶ Including shank and boring head, but without boring cutters.
- ▶ Can order lengthened Boring Head Shank by request.
- ▶ The pre-balance can reach G6.3 5,000 rpm, without an inspection report.
- ▶ The balancing grade and revolution can be done according to customer's request but the additional charge is needed.
- ▶ Cardboard box packing.



PRECISION BORING HEAD

FULL SET

BT / SBJ 高精密 套裝搪孔頭



MODEL NO.	TYPE	BORING CAPACITY	BOING CUTTER W/O INSERTS	WRENCH
17677 - SBJ10	BT30 x SBJ10	8 ~ 21	SBJ-1008-24 / SBJ-1010-30 SBJ-1012-36 / SBJ-1016-48	2
17678 - SBJ10	BT40 x SBJ10	8 ~ 21		2
17679 - SBJ10	BT50 x SBJ10	8 ~ 21		2
17677 - SBJ12	BT30 x SBJ12	8 ~ 26	SBJ-1208-28 / SBJ-1210-35 SBJ-1212-42 / SBJ-1216-56 SBJ-1220-70	2
17678 - SBJ12	BT40 x SBJ12	8 ~ 26		2
17679 - SBJ12	BT50 x SBJ12	8 ~ 26		2
17677	BT30 x SBJ16	8 ~ 50	SBJ-1608-32 / SBJ-1610-40 SBJ-1612-53 / SBJ-1616-68 SBJ-1620-83 / SBJ-1625-90 SBJ-1630-90 / SBJ-1640-90	2
17678	BT40 x SBJ16	8 ~ 50		2
17679	BT50 x SBJ16	8 ~ 50		2

PSC / PMB FINISH BORING HEAD

ONE-PIECE TYPE

PSC / PMB 超微米精搪頭 [一體式]



T W PAT NO. M340139
 T W PAT NO. M363355
 T W PAT NO. M381470
 J P PAT NO. 3154595
 C N PAT NO. ZL200820102784.9
 C N PAT NO. ZL200920139100.7
 D E PAT NO. Nr.202009009848.6
 U S PAT NO. US8109699 B2
 E S PAT NO. 1072386

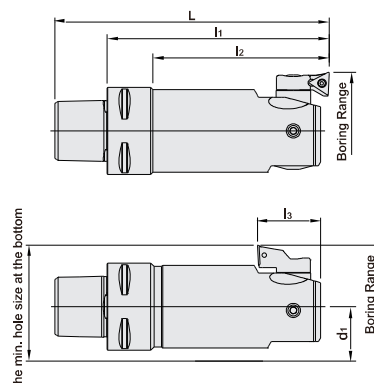

MODEL NO.	TYPE	INSERT SEAT	INSERT	INSERT SCREW	BORING AND PROCESSING AT FRONT					
					BORING RANGE	L	l ₁	l ₂	l ₃	d ₁
140.657.32.085	PSC32 x PMB32 - 85	SIC32 - 1	TB..06 TP..08	M2-5.0-2.7-60	32 ~ 42	104	85	55	25	16
140.657.32.085	PSC32 x PMB32 - 85	SIC32 - 2	TB..06 TP..08	M2-5.0-2.7-60	41 ~ 51	104	85	55	25	16
140.657.32.085	PSC32 x PMB32 - 85	SIC32 - 3	TB..06 TP..08	M2-5.0-2.7-60	50 ~ 60	104	85	55	25	16
141.657.41.102	PSC40 x PMB41 - 102	SIC41 - 1	TP..09 TC..11	M2.5-6.0-3.5-60	41 ~ 54	126	102	70	29	20
141.657.41.102	PSC40 x PMB41 - 102	SIC41 - 2	TP..09 TC..11	M2.5-6.0-3.5-60	50 ~ 63	126	102	70	29	20
141.657.41.102	PSC40 x PMB41 - 102	SIC41 - 3	TP..09 TC..11	M2.5-6.0-3.5-60	61 ~ 74	126	102	70	29	20
142.657.53.112	PSC50 x PMB53 - 112	SIC53 - 1	TP..09 TC..11	M2.5-6.0-3.5-60	53 ~ 70	142	112	74	34	25.5
142.657.53.112	PSC50 x PMB53 - 112	SIC53 - 2	TP..09 TC..11	M2.5-6.0-3.5-60	65 ~ 82	142	112	74	34	25.5
142.657.53.112	PSC50 x PMB53 - 112	SIC53 - 3	TP..09 TC..11	M2.5-6.0-3.5-60	78 ~ 95	142	112	74	34	25.5
143.657.68.140	PSC63 x PMB68 - 140	SIC68 - 1	TP..09 TC..11	M2.5-6.0-3.5-60	68 ~ 100	178	140	90.8	45.2	32.5
143.657.68.140	PSC63 x PMB68 - 140	SIC68 - 2	TP..09 TC..11	M2.5-6.0-3.5-60	94 ~ 126	178	140	90.8	45.2	32.5
143.657.68.140	PSC63 x PMB68 - 140	SIC68 - 3	TP..09 TC..11	M2.5-6.0-3.5-60	118 ~ 150	178	140	90.8	45.2	32.5

TYPES FOR INSERT SEAT:

SUITABLE FINISH BORING HEAD	TYPE	DRAWING	TYPE	DRAWING
PMB32	SIC32 - 1		SIC32 - 1E	
	SIC32 - 2		SIC32 - 2E	
	SIC32 - 3		SIC32 - 3E	
PMB41	SIC41 - 1		SIC41 - 1E	
	SIC41 - 2		SIC41 - 2E	
	SIC41 - 3		SIC41 - 3E	
PMB53	SIC53 - 1	SIC53 - 1E		
	SIC53 - 2	SIC53 - 2E		
	SIC53 - 3	SIC53 - 3E		
PMB68	SIC68 - 1	SIC68 - 1E		
	SIC68 - 2	SIC68 - 2E		
	SIC68 - 3	SIC68 - 3E		

Product information:

- ▶ With the design of PSC one piece boring head to lock with adapters, the total length is shorter than old design and the rigidity and stability are improved!
- ▶ The body of PMB Finish Boring Head is always designed to have coolant outlet.
- ▶ There are 3 types of insert seats and the boring range can be enlarged by exchanging another insert seat.
- ▶ SIC_-1 insert seat is a standard accessory. SIC_-2 and SIC_-3 insert seats are optional accessories and need to be purchased additionally.
- ▶ Inserts are optional accessories. Needs to be purchased additionally.



SUPER MICRON EXCHANGEABLE FINISH BORING HEAD



- ▶ For finish boring, boring range is $\phi 20 \sim \phi 203$.
- ▶ Micro-adjustment unit: each unit is 0.01mm.
- ▶ The insert seat is designed to have a coolant hole at the side, which can extend the use life of inserts, remove the metal chips effectively and is good for heat dissipation.
- ▶ The insert seat has an exchangeable design and the boring range can be enlarged. It can remove the metal chips effectively and avoid interference in the boring process.
- ▶ Suitable for combining with SCK tool holder series and can be used with SCK extension spacer (The Same Diameter/Different Diameter).
- ▶ Adjustable screw with almost no thread clearance to enhance adjusting accuracy. The pre-balance of boring head can apply to boring at high speed.
- ▶ SIC insert seat is designed to have less clearance to connect with boring head, having better rigidity, precision and dust-proof function.



For finish boring, boring range is $\phi 20 \sim \phi 203$. The design is user-friendly, easy to operate and has multi-functional applications.

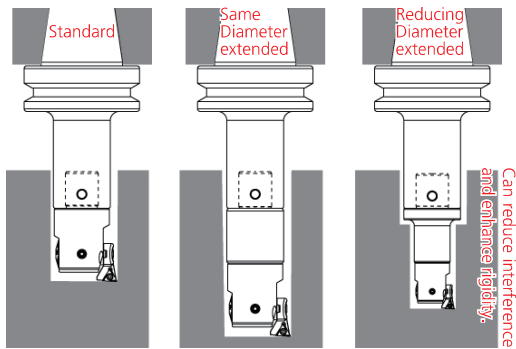

Meet required coaxiality
Back boring by reversing the standard insert seat

In general, users need to reverse the work piece when processing the workpiece by back boring. It not only wastes time but is hard to ensure the coaxiality of the front hole and back hole.

For SMB Finish Boring Head, users just need to reverse the insert seat and can process by back boring. It not only ensures rigidity but also enhances production efficiency.
※ Insert seat SIC-1 can not be used for back boring.

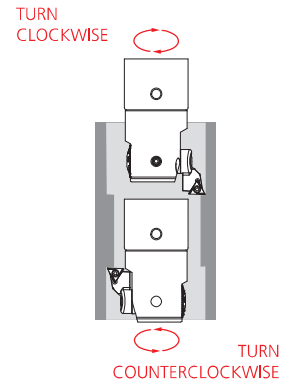

Only need to change insert seat.
Enlarging boring range and improving removal of metal chips.

- ▶ New SIC insert seat is designed to have less clearance to connect with boring head, having better rigidity close to the best rigidity of one piece and extending the use life of inserts.
- ▶ There are 3 types of insert seats for exchanging and boring range can be enlarged.
- ▶ Insert seat SIC-2 and Insert seat SIC-3 can be exchanged to enlarge boring ranges, having larger space for removing metal chips and processing by back boring.

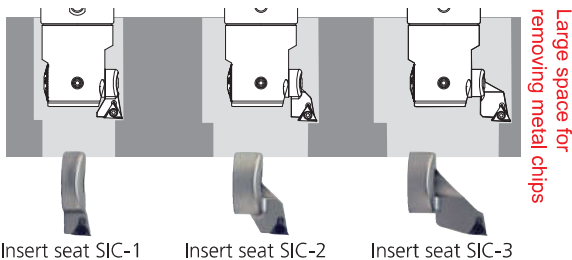

Combination of boring head and SCK tool holder

The combination is easy to operate and has good accuracy and stability just by using a hex wrench to tighten the screw.

Special design on rake 30° for the fixed screw, which makes finish boring head tend to the direction of spindle when the fixed screw is tightened, provides perfect face contact for combining face of finish boring head and SCK tool holder.

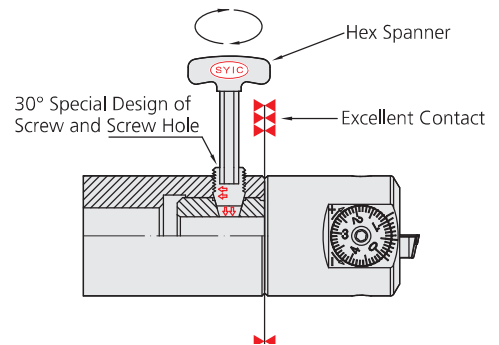

Applicable for high speed boring.
(With pre-balanced design)

The influence of centrifugal force and balance of boring head are considered in our design. Max. boring speed is up to 1000m/min.

No clearance design
Better rigidity, precision and dust-proof function.

SIC insert seat is designed to have almost no clearance to connect with boring head, having better rigidity, precision and dust-proof function.



SUPER MICRON EXCHANGEABLE FINISH BORING HEAD

SMB 超微米精搪頭



台灣精品2009
TAIWAN EXCELLENCE

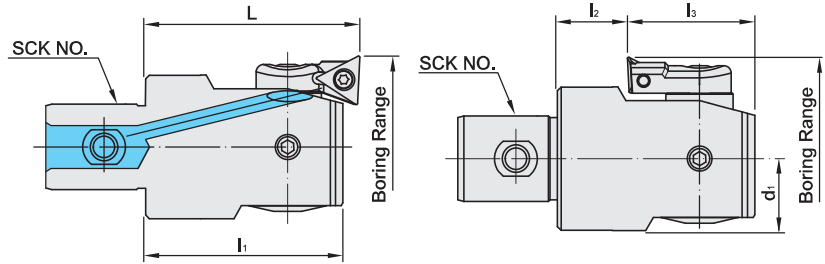

MODEL NO.	TYPE	SCK NO.	BORING AND PROCESSING AT FRONT			BORING AND PROCESSING AT BACK				WEIGHT (KGS)
			BORING RANGE	L	l ₁	BORING RANGE	l ₂	l ₃	d ₁	
19502	SMB20	SCK1	20 ~ 26	32.5	29.5	-	10.5	19.5	10	0.07
			25 ~ 31	32.5	29.5	30 ~ 31	10.5	19.5	10	0.07
			30 ~ 36	32.5	29.5	30 ~ 36	10.5	19.5	10	0.07
19503	SMB25	SCK2	25 ~ 33	35.5	32.5	-	11.5	21	12.5	0.12
			32 ~ 40	35.5	32.5	36 ~ 40	11.5	21	12.5	0.12
			39 ~ 47	35.5	32.5	39 ~ 47	11.5	21	12.5	0.12
19505	SMB32	SCK3	32 ~ 42	40	35	-	10	25	16	0.21
			41 ~ 51	40	35	46 ~ 51	10	25	16	0.21
			50 ~ 60	40	35	50 ~ 60	10	25	16	0.21
19507	SMB41	SCK4	41 ~ 54	47	43	-	14	29	20	0.40
			50 ~ 63	47	43	53 ~ 63	14	29	20	0.40
			61 ~ 74	47	43	61 ~ 74	14	29	20	0.40
19509	SMB53	SCK5	53 ~ 70	57	53	62 ~ 70	19	34	25.5	1.10
			65 ~ 82	57	53	65 ~ 82	19	34	25.5	1.10
			78 ~ 95	57	53	78 ~ 95	19	34	25.5	1.10
19511	SMB68	SCK6	68 ~ 100	71	67.2	80 ~ 100	22	45.2	32.5	1.74
			94 ~ 126	71	67.2	94 ~ 126	22	45.2	32.5	1.74
			118 ~ 150	71	67.2	118 ~ 150	22	45.2	32.5	1.74
19513	SMB100	SCK6	100 ~ 153	71	67.2	112 ~ 153	22	45.2	45.5	2.46
			126 ~ 179	71	67.2	126 ~ 179	22	45.2	45.5	2.46
			150 ~ 203	71	67.2	150 ~ 203	22	45.2	45.5	2.46

TYPES FOR INSERT SEAT:

TYPE	DRAWING	SUITABLE FINISH BORING HEAD	INSERT	TYPE	DRAWING	SUITABLE FINISH BORING HEAD	INSERT
SIC20 - 1		SMB20	TB06 / TP08	SIC20 - 1E		SMB20	TB06 / TP08
SIC20 - 2				SIC20 - 2E			
SIC20 - 3				SIC20 - 3E			
SIC25 - 1		SMB25	TB06 / TP08	SIC25 - 1E		SMB25	TB06 / TP08
SIC25 - 2				SIC25 - 2E			
SIC25 - 3				SIC25 - 3E			
SIC32 - 1		SMB32	TB06 / TP08	SIC32 - 1E		SMB32	TB06 / TP08
SIC32 - 2				SIC32 - 2E			
SIC32 - 3				SIC32 - 3E			
SIC41 - 1		SMB41	TP09 / TC11	SIC41 - 1E		SMB41	TP09 / TC11
SIC41 - 2				SIC41 - 2E			
SIC41 - 3				SIC41 - 3E			
SIC53 - 1		SMB53	TP09 / TC11	SIC53 - 1E		SMB53	TP09 / TC11
SIC53 - 2				SIC53 - 2E			
SIC53 - 3				SIC53 - 3E			
SIC68 - 1		SMB68 / SMB100	TP09 / TC11	SIC68 - 1E		SMB68 / SMB100	TP09 / TC11
SIC68 - 2				SIC68 - 2E			
SIC68 - 3				SIC68 - 3E			

For example: there are different boring ranges for different insert seats of SMB25.

- ▶ SYIC_-1 insert seat is a standard accessory.
- ▶ SYIC_-2 and SYIC_-3 insert seats are optional accessories and need to be purchased additionally.

Product information:

- ▶ Inserts are optional accessories. Needs to be purchased additionally.

STANDARD INSERT SEAT		OPTIONAL INSERT SEAT	
SIC25 - 1	SIC25 - 2	SIC25 - 3	
ψ 25 ~ ψ 33	ψ 32 ~ ψ 40	ψ 39 ~ ψ 47	



SRW ROUGHING BORING HEAD

150mm
830mm

SRW 大孔徑粗搪頭 (150mm 以上系列)

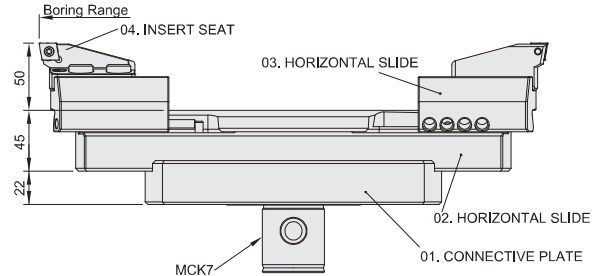

MODEL NO.	TYPE	BORING RANGE		01. CONNECTIVE PLATE	02. HORIZONTAL SLIDE	03. HORIZONTAL SLIDE	04. INSERT SEAT	WEIGHT (KGS)
		MIN.	MAX.					
19532	SRW 150A	150	200	SFL135	SSL150 - 200	SCB150 - 200	SRW150A	7.24
19534	SRW 200A	200	270	SFL135	SSL200 - 270	SCB200 - 550	SRW150A	8.85
19536	SRW 270A	270	340	SFL135	SSL270 - 340	SCB200 - 550	SRW150A	10.3
19538	SRW 340A	340	410	SFL135	SSL340 - 410	SCB200 - 550	SRW150A	11.8
19540	SRW 410A	410	480	SFL135	SSL410 - 480	SCB200 - 550	SRW150A	13.2
19542	SRW 480A	480	550	SFL135	SSL480 - 550	SCB200 - 550	SRW150A	14.7
19544	SRW 550A	550	620	SFL220	SSL550 - 620	SCB200 - 550	SRW150A	18.6
19546	SRW 620A	620	690	SFL220	SSL620 - 690	SCB200 - 550	SRW150A	20.1
19548	SRW 690A	690	760	SFL220	SSL690 - 760	SCB200 - 550	SRW150A	21.5
19550	SRW 760A	760	830	SFL220	SSL760 - 830	SCB200 - 550	SRW150A	22.9

ACCESSORIES

INSERT	SCREW	WRENCH
CC..1204	M5-11-7,5-60	T20

Features:

- ▶ Spare parts can be purchased individually.
- ▶ Series for over 150mm manufacturing diameter: ϕ 150mm ~ ϕ 830mm

Product information:

- ▶ Inserts are optional accessories. Needs to be purchased additionally.

SRW ROUGHING BORING HEAD

150mm
830mm

SRW 大孔徑粗搪頭〔150mm 以上系列〕

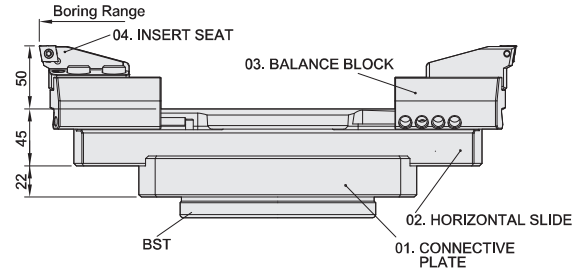

MODEL NO.	TYPE	BORING RANGE		01. CONNECTIVE PLATE	02. HORIZONTAL SLIDE	03. BALANCE BLOCK	04. INSERT SEAT	WEIGHT (KGS)
		MIN.	MAX.					
19532 - BST	SRW 150A - BST	150	200	BST135	SSL150 - 200	SCB150 - 200	SRW150A	7.24
19534 - BST	SRW 200A - BST	200	270	BST135	SSL200 - 270	SCB200 - 550	SRW150A	8.85
19536 - BST	SRW 270A - BST	270	340	BST135	SSL270 - 340	SCB200 - 550	SRW150A	10.3
19538 - BST	SRW 340A - BST	340	410	BST135	SSL340 - 410	SCB200 - 550	SRW150A	11.8
19540 - BST	SRW 410A - BST	410	480	BST135	SSL410 - 480	SCB200 - 550	SRW150A	13.2
19542 - BST	SRW 480A - BST	480	550	BST135	SSL480 - 550	SCB200 - 550	SRW150A	14.7
19544 - BST	SRW 550A - BST	550	620	BST 220	SSL550 - 620	SCB200 - 550	SRW150A	18.6
19546 - BST	SRW 620A - BST	620	690	BST 220	SSL620 - 690	SCB200 - 550	SRW150A	20.1
19548 - BST	SRW 690A - BST	690	760	BST 220	SSL690 - 760	SCB200 - 550	SRW150A	21.5
19550 - BST	SRW 760A - BST	760	830	BST 220	SSL760 - 830	SCB200 - 550	SRW150A	22.9

ACCESSORIES

INSERT	SCREW	WRENCH
CC..1204	M5-11-7.5-60	T20

Features:

- ▶ Spare parts can be purchased individually.
- ▶ Series for over 150mm manufacturing diameter: ϕ 150mm ~ ϕ 830mm

Product information:

- ▶ Inserts are optional accessories. Needs to be purchased additionally.



SMB SUPER MICRON EXCHANGEABLE FINISH BORING HEAD

150mm
830mm

SMB 大孔徑精搪頭〔150mm 以上系列〕

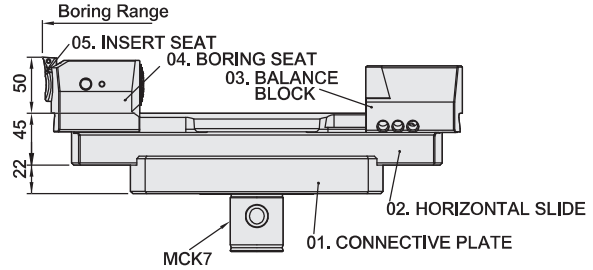

MODEL NO.	TYPE	01. CONNECTIVE PLATE	02. HORIZONTAL SLIDE	03. BALANCE BLOCK	04. BORING SEAT	05. INSERT SEAT	BORING RANGE	INSERT	WEIGHT (KGS)
19562	SMB150	SFL135	SSL150~200	SWB150~200	SMB150L	SIC68-1	150~200	TP09/TC11	10.6
						SIC68-2	176~226	TP09/TC11	10.6
						SIC68-3	200~250	TP09/TC11	10.6
19564	SMB200	SFL135	SSL200~270	SWB200~550	SMB150L	SIC68-1	200~270	TP09/TC11	11.6
						SIC68-2	226~296	TP09/TC11	11.6
						SIC68-3	250~320	TP09/TC11	11.6
19566	SMB270	SFL135	SSL270~340	SWB200~550	SMB150L	SIC68-1	270~340	TP09/TC11	13.0
						SIC68-2	296~366	TP09/TC11	13.0
						SIC68-3	320~390	TP09/TC11	13.0
19568	SMB340	SFL135	SSL340~410	SWB200~550	SMB150L	SIC68-1	340~410	TP09/TC11	14.4
						SIC68-2	366~436	TP09/TC11	14.4
						SIC68-3	390~460	TP09/TC11	14.4
19570	SMB410	SFL135	SSL410~480	SWB200~550	SMB150L	SIC68-1	410~480	TP09/TC11	15.8
						SIC68-2	436~506	TP09/TC11	15.8
						SIC68-3	460~530	TP09/TC11	15.8
19572	SMB480	SFL135	SSL480~550	SWB200~550	SMB150L	SIC68-1	480~550	TP09/TC11	17.2
						SIC68-2	506~576	TP09/TC11	17.2
						SIC68-3	530~600	TP09/TC11	17.2
19574	SMB550	SFL220	SSL550~620	SWB200~550	SMB150L	SIC68-1	550~620	TP09/TC11	20.0
						SIC68-2	576~646	TP09/TC11	20.0
						SIC68-3	600~670	TP09/TC11	20.0
19576	SMB620	SFL220	SSL620~690	SWB200~550	SMB150L	SIC68-1	620~690	TP09/TC11	21.4
						SIC68-2	646~716	TP09/TC11	21.4
						SIC68-3	670~740	TP09/TC11	21.4
19578	SMB690	SFL220	SSL690~760	SWB200~550	SMB150L	SIC68-1	690~760	TP09/TC11	22.9
						SIC68-2	716~786	TP09/TC11	22.9
						SIC68-3	740~810	TP09/TC11	22.9
19580	SMB760	SFL220	SSL760~830	SWB200~550	SMB150L	SIC68-1	760~830	TP09/TC11	24.3
						SIC68-2	786~856	TP09/TC11	24.3
						SIC68-3	810~880	TP09/TC11	24.3

ACCESSORIES

INSERT	SCREW	WRENCH	INSERT	SCREW	WRENCH
TP..0902	M2.5-6.0-3.5-60	T8	TP..1103	M3-8.0-4.0-43	T9

SMB SUPER MICRON EXCHANGEABLE FINISH BORING HEAD

150mm
830mm

SMB 大孔徑精搪頭 (150mm 以上系列)

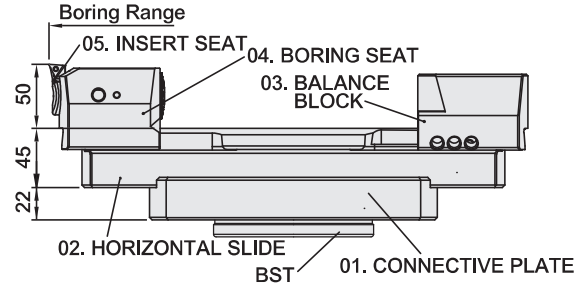

MODEL NO.	TYPE	01. CONNECTIVE PLATE	02. HORIZONTAL SLIDE	03. BALANCE BLOCK	04. BORING SEAT	05. INSERT SEAT	BORING RANGE	INSERT	WEIGHT (KGS)
19562-BST	SMB150-BST	BST135	SSL150~200	SWB150~200	SMB150L	SIC68-1	150~200	TP09/TC11	10.6
						SIC68-2	176~226	TP09/TC11	10.6
						SIC68-3	200~250	TP09/TC11	10.6
19564-BST	SMB200-BST	BST135	SSL200~270	SWB200~550	SMB150L	SIC68-1	200~270	TP09/TC11	11.6
						SIC68-2	226~296	TP09/TC11	11.6
						SIC68-3	250~320	TP09/TC11	11.6
19566-BST	SMB270-BST	BST135	SSL270~340	SWB200~550	SMB150L	SIC68-1	270~340	TP09/TC11	13.0
						SIC68-2	296~366	TP09/TC11	13.0
						SIC68-3	320~390	TP09/TC11	13.0
19568-BST	SMB340-BST	BST135	SSL340~410	SWB200~550	SMB150L	SIC68-1	340~410	TP09/TC11	14.4
						SIC68-2	366~436	TP09/TC11	14.4
						SIC68-3	390~460	TP09/TC11	14.4
19570-BST	SMB410-BST	BST135	SSL410~480	SWB200~550	SMB150L	SIC68-1	410~480	TP09/TC11	15.8
						SIC68-2	436~506	TP09/TC11	15.8
						SIC68-3	460~530	TP09/TC11	15.8
19572-BST	SMB480-BST	BST135	SSL480~550	SWB200~550	SMB150L	SIC68-1	480~550	TP09/TC11	17.2
						SIC68-2	506~576	TP09/TC11	17.2
						SIC68-3	530~600	TP09/TC11	17.2
19574-BST	SMB550-BST	BST220	SSL550~620	SWB200~550	SMB150L	SIC68-1	550~620	TP09/TC11	20.0
						SIC68-2	576~646	TP09/TC11	20.0
						SIC68-3	600~670	TP09/TC11	20.0
19576-BST	SMB620-BST	BST220	SSL620~690	SWB200~550	SMB150L	SIC68-1	620~690	TP09/TC11	21.4
						SIC68-2	646~716	TP09/TC11	21.4
						SIC68-3	670~740	TP09/TC11	21.4
19578-BST	SMB690-BST	BST220	SSL690~760	SWB200~550	SMB150L	SIC68-1	690~760	TP09/TC11	22.9
						SIC68-2	716~786	TP09/TC11	22.9
						SIC68-3	740~810	TP09/TC11	22.9
19580-BST	SMB760-BST	BST220	SSL760~830	SWB200~550	SMB150L	SIC68-1	760~830	TP09/TC11	24.3
						SIC68-2	786~856	TP09/TC11	24.3
						SIC68-3	810~880	TP09/TC11	24.3

ACCESSORIES

INSERT	SCREW	WRENCH	INSERT	SCREW	WRENCH
TP..0902	M2.5-6.0-3.5-60	T8	TP..1103	M3-8.0-4.0-43	T9

SIMPLIFIED TOOL PRESETTER FOR SRW & SMB BORING HEAD

簡易式搪刀設定儀

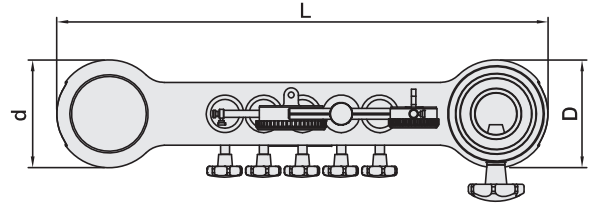

MODEL NO.	TYPE	L	D	d	MEASURING RANGE	SCK NO.	WEIGHT (KGS)
410.550	SET 410-550	410	55	55	$\phi 100 \sim \phi 550$	SCK7	10.4
410.830	SET 410-830	610	55	55	$\phi 550 \sim \phi 830$	SCK7	12.8

Features:

- ▶ Easy operation.
- ▶ Quick dimension adjustment.
- ▶ Specially used for SRW & SMB boring heads for boring dia. over 150mm. (Measuring range: $\phi 100\text{mm} \sim \phi 830\text{mm}$)
- ▶ Each unit of dial indicator: Radial: 0.02mm / Axial: 0.01mm.

BT / SCK BORING HEAD SHANK

BT / SCK 搪孔刀柄

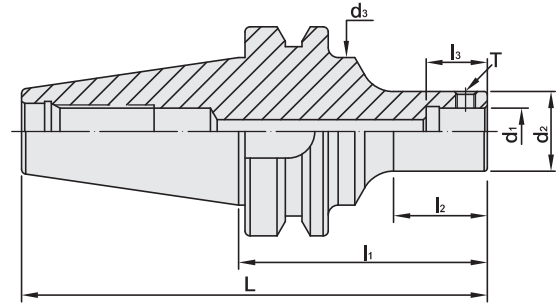







MODEL NO.	TYPE	L	l ₁	l ₂	l ₃	d ₁	d ₂	d ₃	T	Fig	WEIGHT (KGS)
17530	BT30 x SCK1 - 55	103.4	55	28	18	11	19	-	M4 x 0.7P	2	0.70
17532	BT30 x SCK2 - 60	108.4	60	33	18.5	14	23.5	-	M5 x 0.8P	2	0.80
17533	BT30 x SCK2 - 75	123.4	75	48	18.5	14	23.5	-	M5 x 0.8P	2	0.80
17534	BT30 x SCK3 - 50	98.4	50	26	24	18	31	-	M6 x 1.0P	2	0.90
17536	BT30 x SCK4 - 60	108.4	60	37	28	22	39	-	M8 x 1.25P	2	1.00
17537	BT30 x SCK4 - 70	118.4	70	47	28	22	39	-	M8 x 1.25P	2	1.00
17538	BT30 x SCK5 - 70	118.4	70	47	35	28	50	-	M10 x 1.5P	2	1.10
17540	BT30 x SCK6 - 60	108.4	60	38	42	36	63	-	M12 x 1.75P	2	1.20
17501	BT40 x SCK1 - 100	165.4	100	51	18	11	19	44.45	M4 x 0.7P	1	1.20
17501 - 115	BT40 x SCK1 - 115	180.4	115	66	18	11	19	44.45	M4 x 0.7P	1	1.30
17502	BT40 x SCK2 - 75	140.4	75	28	18.5	14	23.5	44.45	M5 x 0.8P	1	1.14
17503	BT40 x SCK3 - 80	145.4	80	48	24	18	31	-	M6 x 1.0P	2	1.22
17504	BT40 x SCK4 - 70	135.4	70	40	28	22	39	-	M8 x 1.25P	2	1.50
17505	BT40 x SCK4 - 100	165.4	100	70	28	22	39	-	M8 x 1.25P	2	1.56
17506	BT40 x SCK5 - 60	125.4	60	30	35	28	50	-	M10 x 1.5P	2	1.30
17507	BT40 x SCK5 - 80	145.4	80	51	35	28	50	-	M10 x 1.5P	2	1.60
17508	BT40 x SCK6 - 55	120.4	55	28	42	36	63	-	M12 x 1.75P	2	2.15

Features:

- ▶ Extension spacers are applicable, more convenient for boring.
- ▶ Internal tolerance is H6.

Product information:

- ▶ The pre-balance reaches G6.3 5,000 rpm. Higher balancing grade and revolution can be done upon request but additional charge is needed.
- ▶ AD+B type is available, please inform us when making an order.
- ▶ MAS/BT30 tool holders are without coolant supply over collars.

Pull Stud	EXTENSION SPACER	SCK	SMB	SBJ	SMU
					
P.W-54~55	P.M-51	P.M-3	P.M-12~13	P.M-4	P.M-2



BT / SCK BORING HEAD SHANK

BT / SCK 搪孔刀柄

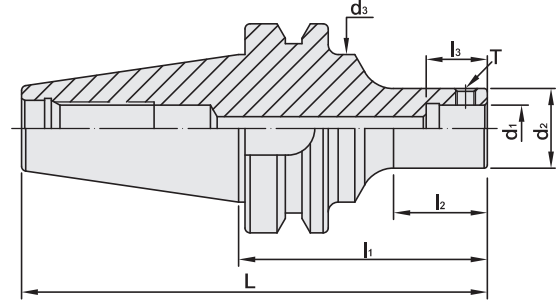

MODEL NO.	TYPE	L	l ₁	l ₂	l ₃	d ₁	d ₂	d ₃	T	Fig	WEIGHT (KGS)
17509	BT50 x SCK1 - 105	206.8	105	38	18	11	19	69.85	M4 x 0.7P	1	3.90
17510	BT50 x SCK2 - 105	206.8	105	39	18.5	14	23.5	69.85	M5 x 0.8P	1	4.00
17510 - 135	BT50 x SCK2 - 135	236.8	135	67	18.5	14	23.5	69.85	M5 x 0.8P	1	4.10
17511	BT50 x SCK3 - 110	211.8	110	62	24	18	31	-	M6 x 1.0P	2	4.40
17512	BT50 x SCK3 - 140	241.8	140	92	24	18	31	-	M6 x 1.0P	2	4.60
17513	BT50 x SCK4 - 100	201.8	100	52	28	22	39	-	M8 x 1.25P	2	4.80
17514	BT50 x SCK4 - 160	261.8	160	112	28	22	39	-	M8 x 1.25P	2	5.20
17515	BT50 x SCK5 - 90	191.8	90	42	35	28	50	-	M10 x 1.5P	2	5.40
17516	BT50 x SCK5 - 165	266.8	165	117	35	28	50	-	M10 x 1.5P	2	6.20
17517	BT50 x SCK5 - 210	311.8	210	162	35	28	50	-	M10 x 1.5P	2	6.40
17518	BT50 x SCK6 - 85	186.8	85	37	42	36	63	-	M12 x 1.75P	2	5.90
17519	BT50 x SCK6 - 155	256.8	155	107	42	36	63	-	M12 x 1.75P	2	6.50
17520	BT50 x SCK6 - 215	316.8	215	167	42	36	63	-	M12 x 1.75P	2	6.90

Features:

- ▶ Extension spacers are applicable, more convenient for boring.
- ▶ Internal tolerance is H6.

Product information:

- ▶ The pre-balance reaches G6.3 5,000 rpm. Higher balancing grade and revolution can be done upon request but additional charge is needed.

Pull Stud	EXTENSION SPACER	SCK	SMB	SBJ	SMU
					
P.W-54~55	P.M-51	P.M-3	P.M-12~13	P.M-4	P.M-2

BT / SCK BORING HEAD SHANK

EXTENSION TYPE

BT / SCK 搪孔刀柄 [加長斜度柄]

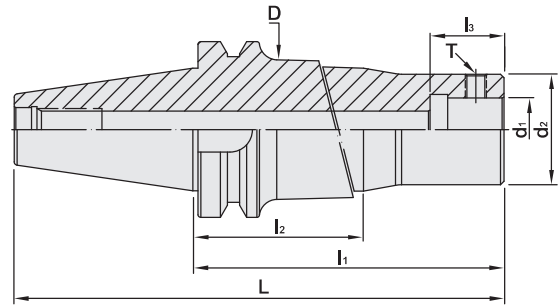

MODEL NO.	TYPE	L	l ₁	l ₂	l ₃	D	d ₁	d ₂	T	WEIGHT (KGS)
17520 - 240BG	BT50 x SCK6 - 240BG	421.8	320	240	42	80	36	63	M12 x 1.75P	12.18
17521 - 240BG	BT50 x SCK6 - 240BG	421.8	320	240	42	100	36	63	M12 x 1.75P	16.26
17520 - 300BG	BT50 x SCK6 - 300BG	481.8	380	300	42	80	36	63	M12 x 1.75P	14.05
17521 - 300BG	BT50 x SCK6 - 300BG	481.8	380	300	42	100	36	63	M12 x 1.75P	19.37
17520 - 360BG	BT50 x SCK6 - 360BG	541.8	440	360	42	80	36	63	M12 x 1.75P	15.94
17521 - 360BG	BT50 x SCK6 - 360BG	541.8	440	360	42	100	36	63	M12 x 1.75P	22.46

Features:

- ▶ It's easy to fasten SCK boring head and shank with a hex spanner.
- ▶ 30° special design of screw and screw hole facilitates good repeated positioning accuracy.
- ▶ When fastening the screw, SCK boring head and SCK boring shank have excellent contact. The rigidity is improved a lot!
- ▶ Internal hole tolerance: H6.
- ▶ The tool holder is through-hole, which is better for water to get through and anti-vibration.
- ▶ Exchangeable with "CK" series of tool holders.
- ▶ The side lock screw and key slot is 90°.
- ▶ AD+B type is available, please inform us when making an order.

Pull Stud	EXTENSION SPACER	SCK	SMB	SBJ	SMU
P.W-54~55	P.M-51	P.M-3	P.M-12~13	P.M-4	P.M-2



BT / MCK BORING HEAD SHANK

BT / MCK 搪孔刀柄

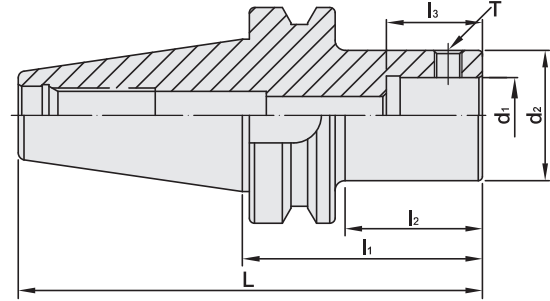

MODEL NO.	TYPE	L	l ₁	l ₂	l ₃	d ₁	d ₂	T	WEIGHT (KGS)
17530M	BT30 x MCK1 - 55	103.4	55	28	18	11	19	M4 x 0.5P	0.70
17530M - 70	BT30 x MCK1 - 70	118.4	70	43	18	11	19	M4 x 0.5P	0.80
17532M	BT30 x MCK2 - 60	108.4	60	33	18.5	14	23.5	M5 x 0.5P	0.80
17533M	BT30 x MCK2 - 75	123.4	75	48	18.5	14	23.5	M5 x 0.5P	0.80
17532M - 80	BT30 x MCK2 - 80	128.4	80	53	18.5	14	23.5	M5 x 0.5P	0.81
17534M	BT30 x MCK3 - 50	98.4	50	26	24	18	31	M6 x 0.75P	0.90
17534M - 80	BT30 x MCK3 - 80	128.4	80	56	24	18	31	M6 x 0.75P	0.95
17536M	BT30 x MCK4 - 60	108.4	60	37	28	22	39	M8 x 0.75P	1.00
17537M	BT30 x MCK4 - 70	118.4	70	47	29	22	39	M8 x 0.75P	1.00
17538M	BT30 x MCK5 - 70	118.4	70	47	35	28	50	M10 x 1.0P	1.10
17540M	BT30 x MCK6 - 60	108.4	60	38	42	36	63	M12 x 1.0P	1.20

Features:

- ▶ Extension spacers are applicable, more convenient for boring.
- ▶ Internal tolerance is H6.

Product information:

- ▶ The pre-balance reaches G6.3 5,000 rpm. Higher balancing grade and revolution can be done upon request but additional charge is needed.
- ▶ MAS/BT30 tool holders are without coolant supply over collars.

Pull Stud	EXTENSION SPACER	SCK	SMB	SBJ	SMU
P.W-54~55	P.M-51	P.M-3	P.M-12~13	P.M-4	P.M-2

BT / MCK BORING HEAD SHANK

BT / MCK 搪孔刀柄

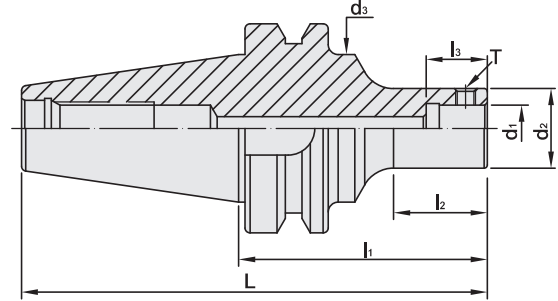

MODEL NO.	TYPE	L	l ₁	l ₂	l ₃	d ₁	d ₂	d ₃	T	Fig	WEIGHT (KGS)
17501M	BT40 x MCK1 - 100	165.4	100	51	18	11	19	44.45	M4 x 0.5P	1	1.20
17501M - 115	BT40 x MCK1 - 115	180.4	115	66	18	11	19	44.45	M4 x 0.5P	1	1.30
17502M	BT40 x MCK2 - 75	140.4	75	28	18.5	14	23.5	44.45	M5 x 0.5P	1	1.14
17502M - 85	BT40 x MCK2 - 85	150.4	85	38	18.5	14	23.5	44.45	M5 x 0.5P	1	1.24
17502M - 115	BT40 x MCK2 - 115	180.4	115	68	18.5	14	23.5	44.45	M5 x 0.5P	1	1.30
17502M - 175	BT40 x MCK2 - 175	240.4	175	128	18.5	14	23.5	44.45	M5 x 0.5P	1	1.40
17503M	BT40 x MCK3 - 80	145.4	80	48	24	18	31	-	M6 x 0.75P	2	3.90
17503M - 95	BT40 x MCK3 - 95	160.4	95	63	24	18	31	-	M6 x 0.75P	2	4.00
17503M - 125	BT40 x MCK3 - 125	190.4	125	93	24	18	31	-	M6 x 0.75P	2	4.10
17503M - 155	BT40 x MCK3 - 155	220.4	155	123	24	18	31	-	M6 x 0.75P	2	4.00
17503M - 200	BT40 x MCK3 - 200	265.4	200	168	24	18	31	-	M6 x 0.75P	2	4.10
17504M	BT40 x MCK4 - 70	135.4	70	40	28	22	39	-	M8 x 0.75P	2	4.20
17505M	BT40 x MCK4 - 100	165.4	100	70	28	22	39	-	M8 x 0.75P	2	4.40
17505M - 120	BT40 x MCK4 - 120	185.4	120	85	28	22	39	-	M8 x 0.75P	2	4.50
17505M - 130	BT40 x MCK4 - 130	195.4	130	98	28	22	39	-	M8 x 0.75P	2	1.66
17505M - 150	BT40 x MCK4 - 150	215.4	150	115	28	22	39	-	M8 x 0.75P	2	1.70
17505M - 175	BT40 x MCK4 - 175	240.4	175	143	28	22	39	-	M8 x 0.75P	2	1.76
17505M - 195	BT40 x MCK4 - 195	260.4	195	163	28	22	39	-	M8 x 0.75P	2	1.80

Features:

- ▶ Extension spacers are applicable, more convenient for boring.
- ▶ Internal tolerance is H6.

Product information:

- ▶ The pre-balance reaches G6.3 5,000 rpm. Higher balancing grade and revolution can be done upon request but additional charge is needed.
- ▶ AD+B type is available, please inform us when making an order.

Pull Stud	EXTENSION SPACER	SCK	SMB	SBJ	SMU
P.W-54~55	P.M-51	P.M-3	P.M-12~13	P.M-4	P.M-2



BT / MCK BORING HEAD SHANK

BT / MCK 搪孔刀柄

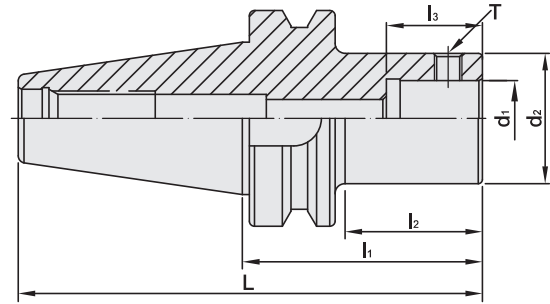







MODEL NO.	TYPE	L	l ₁	l ₂	l ₃	d ₁	d ₂	T	WEIGHT (KGS)
17506M	BT40 x MCK5 - 60	125.4	60	30	35	28	50	M10 x 1.0P	1.30
17507M	BT40 x MCK5 - 80	145.4	80	51	35	28	50	M10 x 1.0P	1.60
17507M - 100	BT40 x MCK5 - 100	165.4	100	70	35	28	50	M10 x 1.0P	1.65
17507M - 120	BT40 x MCK5 - 120	185.4	120	90	35	28	50	M10 x 1.0P	1.69
17507M - 125	BT40 x MCK5 - 125	190.4	125	96	35	28	50	M10 x 1.0P	1.70
17507M - 150	BT40 x MCK5 - 150	215.4	150	120	35	28	50	M10 x 1.0P	1.80
17507M - 175	BT40 x MCK5 - 175	240.4	175	146	35	28	50	M10 x 1.0P	1.90
17508M	BT40 x MCK6 - 55	120.4	55	28	42	36	63	M12 x 1.0P	2.15
17508M - 65	BT40 x MCK6 - 65	130.4	65	38	42	36	63	M12 x 1.0P	2.20
17508M - 100	BT40 x MCK6 - 100	165.4	100	73	42	36	63	M12 x 1.0P	2.30
17508M - 115	BT40 x MCK6 - 115	180.4	115	88	42	36	63	M12 x 1.0P	2.40
17508M - 120	BT40 x MCK6 - 120	185.4	120	93	42	36	63	M12 x 1.0P	2.41
17508M - 150	BT40 x MCK6 - 150	215.4	150	123	42	36	63	M12 x 1.0P	2.45
17508M - 165	BT40 x MCK6 - 165	230.4	165	138	42	36	63	M12 x 1.0P	2.50

Features:

- ▶ Extension spacers are applicable, more convenient for boring.
- ▶ Internal tolerance is H6.

Product information:

- ▶ The pre-balance reaches G6.3 5,000 rpm. Higher balancing grade and revolution can be done upon request but additional charge is needed.
- ▶ AD+B type is available, please inform us when making an order.

Pull Stud	EXTENSION SPACER	SCK	SMB	SBJ	SMU
					
P.W-54~55	P.M-51	P.M-3	P.M-12~13	P.M-4	P.M-2

BT / MCK BORING HEAD SHANK

BT / MCK 搪孔刀柄

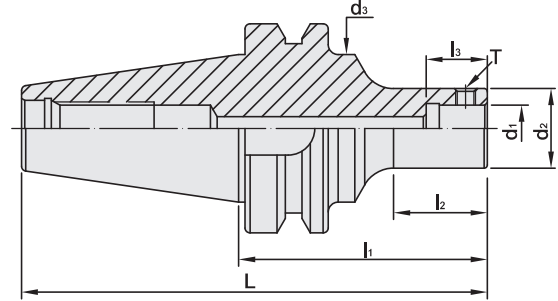

MODEL NO.	TYPE	L	l ₁	l ₂	l ₃	d ₁	d ₂	d ₃	T	Fig	WEIGHT (KGS)
17509M	BT50 x MCK1 - 105	206.8	105	38	18	11	19	69.85	M4 x 0.5P	1	3.90
17509M - 115	BT50 x MCK1 - 115	216.8	115	48	18	11	19	69.85	M4 x 0.5P	1	4.00
17509M - 145	BT50 x MCK1 - 145	246.8	145	78	18	11	19	69.85	M4 x 0.5P	1	4.10
17510M	BT50 x MCK2 - 105	206.8	105	39	18.5	14	23.5	69.85	M5 x 0.5P	1	4.00
17510M - 135	BT50 x MCK2 - 135	236.8	135	67	18.5	14	23.5	69.85	M5 x 0.5P	1	4.10
17510M - 140	BT50 x MCK2 - 140	241.8	140	74	18.5	14	23.5	69.85	M5 x 0.5P	1	4.20
17510M - 175	BT50 x MCK2 - 175	276.8	175	109	18.5	14	23.5	69.85	M5 x 0.5P	1	4.40
17510M - 225	BT50 x MCK2 - 225	326.8	225	159	18.5	14	23.5	69.85	M5 x 0.5P	1	4.50
17511M	BT50 x MCK3 - 110	211.8	110	62	24	18	31	-	M6 x 0.75P	2	4.40
17512M	BT50 x MCK3 - 140	241.8	140	92	24	18	31	-	M6 x 0.75P	2	4.60
17512M - 155	BT50 x MCK3 - 155	256.8	155	107	24	18	31	-	M6 x 0.75P	2	4.80
17512M - 200	BT50 x MCK3 - 200	301.8	200	152	24	18	31	-	M6 x 0.75P	2	5.00
17512M - 240	BT50 x MCK3 - 240	341.8	240	192	24	18	31	-	M6 x 0.75P	2	5.20
17513M	BT50 x MCK4 - 100	201.8	100	52	28	22	39	-	M8 x 0.75P	2	4.80
17514M	BT50 x MCK4 - 160	261.8	160	112	28	22	39	-	M8 x 0.75P	2	5.20
17514M - 175	BT50 x MCK4 - 175	276.8	175	127	28	22	39	-	M8 x 0.75P	2	2.30
17514M - 205	BT50 x MCK4 - 205	306.8	205	160	28	22	39	-	M8 x 0.75P	2	5.40
17514M - 235	BT50 x MCK4 - 235	336.8	235	187	28	22	39	-	M8 x 0.75P	2	5.50
17514M - 265	BT50 x MCK4 - 265	366.8	265	217	28	22	39	-	M8 x 0.75P	2	5.60

Features:

- ▶ Extension spacers are applicable, more convenient for boring.
- ▶ Internal tolerance is H6.

Product information:

- ▶ The pre-balance reaches G6.3 5,000 rpm. Higher balancing grade and revolution can be done upon request but additional charge is needed.
- ▶ AD+B type is available, please inform us when making an order.

Pull Stud	EXTENSION SPACER	SCK	SMB	SBJ	SMU
P.W-54~55	P.M-51	P.M-3	P.M-12~13	P.M-4	P.M-2



BT / MCK BORING HEAD SHANK

BT / MCK 搪孔刀柄

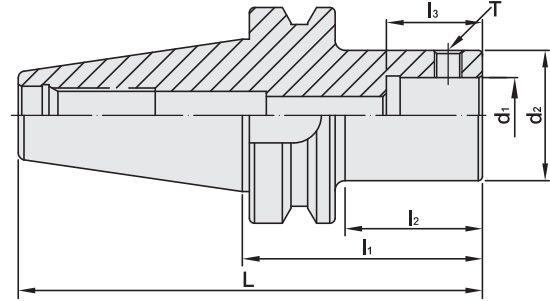

MODEL NO.	TYPE	L	l ₁	l ₂	l ₃	d ₁	d ₂	T	WEIGHT (KGS)
17515M	BT50 x MCK5 - 90	191.8	90	42	35	28	50	M10 x 1.0P	5.40
17515M - 105	BT50 x MCK5 - 105	206.8	105	57	35	28	50	M10 x 1.0P	5.60
17515M - 110	BT50 x MCK5 - 110	211.8	110	62	35	28	50	M10 x 1.0P	5.70
17516M	BT50 x MCK5 - 165	266.8	165	117	35	28	50	M10 x 1.0P	6.20
17516M - 185	BT50 x MCK5 - 185	286.8	185	137	35	28	50	M10 x 1.0P	6.30
17517M	BT50 x MCK5 - 210	311.8	210	162	35	28	50	M10 x 1.0P	6.40
17517M - 240	BT50 x MCK5 - 240	341.8	240	192	35	28	50	M10 x 1.0P	6.60
17517M - 265	BT50 x MCK5 - 265	366.8	265	217	35	28	50	M10 x 1.0P	6.70
17517M - 300	BT50 x MCK5 - 300	401.8	300	252	35	28	50	M10 x 1.0P	6.80
17518M	BT50 x MCK6 - 85	186.8	85	37	42	36	63	M12 x 1.0P	5.90
17519M	BT50 x MCK6 - 155	256.8	155	107	42	36	63	M12 x 1.0P	6.50
17520M	BT50 x MCK6 - 215	316.8	215	167	42	36	63	M12 x 1.0P	6.90
17520M - 240	BT50 x MCK6 - 240	341.8	240	192	42	36	63	M12 x 1.0P	6.95
17520M - 265	BT50 x MCK6 - 265	366.8	265	217	42	36	63	M12 x 1.0P	7.00
17520M - 290	BT50 x MCK6 - 290	391.8	290	242	42	36	63	M12 x 1.0P	7.10
17520M - 300	BT50 x MCK6 - 300	401.8	300	252	42	36	63	M12 x 1.0P	7.12
17520M - 350	BT50 x MCK6 - 350	451.8	350	302	42	36	63	M12 x 1.0P	7.50
17522M - 93	BT50 x MCK7 - 93	194.8	93	52	52	46	90	M20 x 1.5P	5.00
17522M - 183	BT50 x MCK7 - 183	284.8	183	142	52	46	90	M20 x 1.5P	9.40
17522M - 243	BT50 x MCK7 - 243	344.8	243	202	52	46	90	M20 x 1.5P	6.90

Features:

- ▶ Extension spacers are applicable, more convenient for boring.
- ▶ Internal tolerance is H6.

Product information:

- ▶ The pre-balance reaches G6.3 5,000 rpm. Higher balancing grade and revolution can be done upon request but additional charge is needed.
- ▶ AD+B type is available, please inform us when making an order.

Pull Stud	EXTENSION SPACER	SCK	SMB	SBJ	SMU	SRW	SMB
P.W-54~55	P.M-51	P.M-3	P.M-12~13	P.M-4	P.M-2	P.M-14	P.M-16

CAT / SCK BORING HEAD SHANK

CAT / SCK 搪孔刀柄

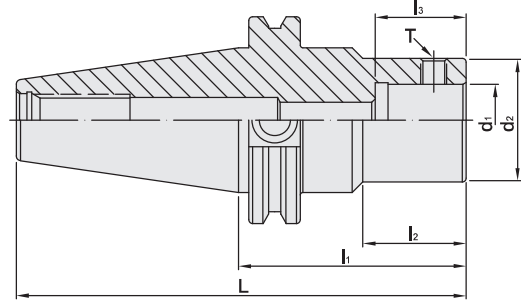

INCHES





MODEL NO.	TYPE	L	l ₁	l ₂	l ₃	d ₁	d ₂	T	WEIGHT (KGS)
27910	CAT40 x SCK1 - 3"	5.687	3	1.105	0.708	0.433	0.748	M4 x 0.7P	1.20
27912	CAT40 x SCK1 - 3.75"	6.437	3.75	1.856	0.708	0.433	0.748	M4 x 0.7P	1.25
27914	CAT40 x SCK2 - 3"	5.687	3	1.39	0.728	0.551	0.925	M5 x 0.8P	1.30
27916	CAT40 x SCK2 - 4.35"	7.037	4.35	2.656	0.728	0.551	0.925	M5 x 0.8P	1.35
27918	CAT40 x SCK3 - 3"	5.687	3	1.356	0.945	0.709	1.22	M6 x 1.0P	1.40
27920	CAT40 x SCK3 - 5"	7.687	5	3.36	0.945	0.709	1.22	M6 x 1.0P	1.45
27922	CAT40 x SCK4 - 3"	5.687	3	1.515	1.102	0.866	1.535	M8 x 1.25P	1.50
27924	CAT40 x SCK4 - 4.25"	6.937	4.25	2.765	1.102	0.866	1.535	M8 x 1.25P	1.55
27926	CAT40 x SCK5 - 3"	5.687	3	2.219	1.378	1.102	1.969	M10 x 1.5P	1.60
27928	CAT40 x SCK5 - 4.25"	6.937	4.25	3.469	1.378	1.102	1.969	M10 x 1.5P	1.65
27930	CAT40 x SCK6 - 3"	5.687	3	2.219	1.653	1.417	2.48	M12 x 1.75P	1.70
27932	CAT40 x SCK6 - 4.25"	6.937	4.25	3.469	1.653	1.417	2.48	M12 x 1.75P	1.75
27934	CAT50 x SCK1 - 3.5"	7.5	3.5	1.317	0.708	0.433	0.748	M4 x 0.7P	3.30
27936	CAT50 x SCK1 - 4"	8	4	1.817	0.708	0.433	0.748	M4 x 0.7P	3.35
27938	CAT50 x SCK2 - 3.5"	7.5	3.5	1.368	0.728	0.551	0.925	M5 x 0.8P	3.40
27940	CAT50 x SCK2 - 5.3"	9.3	5.3	3.167	0.728	0.551	0.925	M5 x 0.8P	3.45
27942	CAT50 x SCK3 - 3.5"	7.5	3.5	1.453	0.945	0.709	1.22	M6 x 1.0P	3.50
27944	CAT50 x SCK3 - 5.5"	9.5	5.5	3.453	0.945	0.709	1.22	M6 x 1.0P	3.55
27946	CAT50 x SCK4 - 3.5"	7.5	3.5	1.544	1.102	0.866	1.535	M8 x 1.25P	3.60
27948	CAT50 x SCK4 - 5.5"	9.5	5.5	3.544	1.102	0.866	1.535	M8 x 1.25P	3.65
27950	CAT50 x SCK5 - 3.5"	7.5	3.5	1.669	1.378	1.102	1.969	M10 x 1.5P	3.70
27952	CAT50 x SCK5 - 5.5"	9.5	5.5	3.669	1.378	1.102	1.969	M10 x 1.5P	3.75
27954	CAT50 x SCK6 - 3.5"	7.5	3.5	1.988	1.653	1.417	2.48	M12 x 1.75P	3.80
27956	CAT50 x SCK6 - 5.5"	9.5	5.5	3.987	1.653	1.417	2.48	M12 x 1.75P	3.85

Features:

- ▶ Extension spacers are applicable, more convenient for boring.
- ▶ Internal tolerance is H6.

Product information:

- ▶ The pre-balance reaches G6.3 5,000 rpm. Higher balancing grade and revolution can be done upon request but additional charge is needed.
- ▶ AD+B type is available, please inform us when making an order.

Pull Stud	EXTENSION SPACER	SCK	SMB	SBJ	SMU
					
P.W-56	P.M-51	P.M-3	P.M-12~13	P.M-4	P.M-2



CAT / MCK BORING HEAD SHANK

CAT / MCK 搪孔刀柄

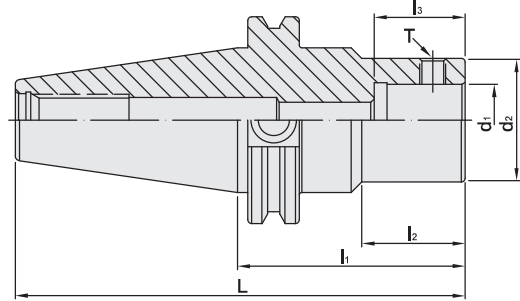

INCHES

MODEL NO.	TYPE	L	l ₁	l ₂	l ₃	d ₁	d ₂	T	WEIGHT (KGS)
27910M	CAT40 x MCK1 - 3"	5.687	3	1.105	0.708	0.433	0.748	M4 x 0.5P	1.20
27912M	CAT40 x MCK1 - 3.75"	6.437	3.75	1.856	0.708	0.433	0.748	M4 x 0.5P	1.25
27914M	CAT40 x MCK2 - 3"	5.687	3	1.39	0.728	0.551	0.925	M5 x 0.5P	1.30
27916M	CAT40 x MCK2 - 4.35"	7.037	4.35	2.656	0.728	0.551	0.925	M5 x 0.5P	1.35
27918M	CAT40 x MCK3 - 3"	5.687	3	1.356	0.945	0.709	1.22	M6 x 0.75P	1.40
27920M	CAT40 x MCK3 - 5"	7.687	5	3.36	0.945	0.709	1.22	M6 x 0.75P	1.45
27922M	CAT40 x MCK4 - 3"	5.687	3	1.515	1.102	0.866	1.535	M8 x 0.75P	1.50
27924M	CAT40 x MCK4 - 4.25"	6.937	4.25	2.765	1.102	0.866	1.535	M8 x 0.75P	1.55
27926M	CAT40 x MCK5 - 3"	5.687	3	2.219	1.378	1.102	1.969	M10 x 1.0P	1.60
27928M	CAT40 x MCK5 - 4.25"	6.937	4.25	3.469	1.378	1.102	1.969	M10 x 1.0P	1.65
27930M	CAT40 x MCK6 - 3"	5.687	3	2.219	1.653	1.417	2.48	M12 x 1.0P	1.70
27932M	CAT40 x MCK6 - 4.25"	6.937	4.25	3.469	1.653	1.417	2.48	M12 x 1.0P	1.75
27934M	CAT50 x MCK1 - 3.5"	7.5	3.5	1.317	0.708	0.433	0.748	M4 x 0.5P	3.30
27936M	CAT50 x MCK1 - 4"	8	4	1.817	0.708	0.433	0.748	M4 x 0.5P	3.35
27938M	CAT50 x MCK2 - 3.5"	7.5	3.5	1.368	0.728	0.551	0.925	M5 x 0.5P	3.40
27940M	CAT50 x MCK2 - 5.3"	9.3	5.3	3.167	0.728	0.551	0.925	M5 x 0.5P	3.45
27942M	CAT50 x MCK3 - 3.5"	7.5	3.5	1.453	0.945	0.709	1.22	M6 x 0.75P	3.50
27944M	CAT50 x MCK3 - 5.5"	9.5	5.5	3.453	0.945	0.709	1.22	M6 x 0.75P	3.55
27946M	CAT50 x MCK4 - 3.5"	7.5	3.5	1.544	1.102	0.866	1.535	M8 x 0.75P	3.60
27948M	CAT50 x MCK4 - 5.5"	9.5	5.5	3.544	1.102	0.866	1.535	M8 x 0.75P	3.65
27950M	CAT50 x MCK5 - 3.5"	7.5	3.5	1.669	1.378	1.102	1.969	M10 x 1.0P	3.70
27952M	CAT50 x MCK5 - 5.5"	9.5	5.5	3.669	1.378	1.102	1.969	M10 x 1.0P	3.75
27954M	CAT50 x MCK6 - 3.5"	7.5	3.5	1.988	1.653	1.417	2.48	M12 x 1.0P	3.80
27956M	CAT50 x MCK6 - 5.5"	9.5	5.5	3.987	1.653	1.417	2.48	M12 x 1.0P	3.85
27958M	CAT50 x MCK7 - 3.74"	7.74	3.74	2.362	2.047	1.811	3.54	M20 x 1.5P	5.00

Features:

- ▶ Extension spacers are applicable, more convenient for boring. ▶ Internal tolerance is H6.

Product information:

- ▶ The pre-balance reaches G6.3 5,000 rpm. Higher balancing grade and revolution can be done upon request but additional charge is needed.
- ▶ AD+B type is available, please inform us when making an order.

Pull Stud	EXTENSION SPACER	SCK	SMB	SBJ	SMU	SRW	SMB
P.W-56	P.M-51	P.M-3	P.M-12~13	P.M-4	P.M-2	P.M-14	P.M-16

DAT / SCK BORING HEAD SHANK

DAT / SCK 搪孔刀柄

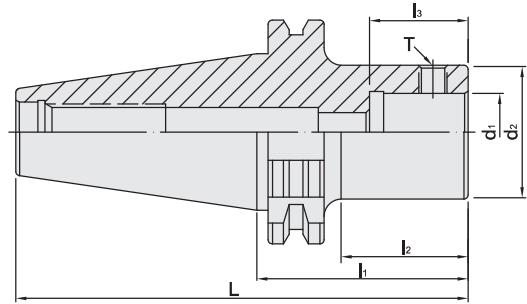

MODEL NO.	TYPE	L	l ₁	l ₂	l ₃	d ₁	d ₂	T	WEIGHT (KGS)
47502	DAT30 x SCK1 - 50	97.8	50	27.9	18	11	19	M4 x 0.7P	0.60
47504	DAT30 x SCK2 - 65	112.8	65	42.9	18.5	14	23.5	M5 x 0.8P	0.70
47506	DAT30 x SCK3 - 50	97.8	50	27.9	24	18	31	M6 x 1.0P	0.80
47508	DAT30 x SCK4 - 50	97.8	50	27.9	28	22	39	M8 x 1.25P	1.30
47510	DAT40 x SCK1 - 80	148.4	80	50.9	18	11	19	M4 x 0.7P	1.00
47512	DAT40 x SCK1 - 95	163.4	95	65.9	18	11	19	M4 x 0.7P	1.05
47514	DAT40 x SCK2 - 80	148.4	80	50.9	18.5	14	23.5	M5 x 0.8P	1.10
47516	DAT40 x SCK2 - 110	178.4	110	80.9	18.5	14	23.5	M5 x 0.8P	1.15
47518	DAT40 x SCK3 - 90	158.4	90	65.9	24	18	31	M6 x 1.0P	1.20
47520	DAT40 x SCK3 - 125	193.4	125	100.9	24	18	31	M6 x 1.0P	1.25
47522	DAT40 x SCK4 - 80	148.4	80	55.9	28	22	39	M8 x 1.25P	1.30
47524	DAT40 x SCK4 - 110	178.4	110	85.9	28	22	39	M8 x 1.25P	1.35
47526	DAT40 x SCK5 - 95	163.4	95	75.4	35	28	50	M10 x 1.5P	1.40
47528	DAT40 x SCK5 - 110	178.4	110	90.4	35	28	50	M10 x 1.5P	1.45
47530	DAT40 x SCK6 - 65	133.4	65	45.4	42	36	63	M12 x 1.75P	1.50
47532	DAT40 x SCK6 - 95	163.4	95	75.4	42	36	63	M12 x 1.75P	1.55
47534	DAT50 x SCK1 - 110	211.75	110	80.9	18	11	19	M4 x 0.7P	3.10
47536	DAT50 x SCK1 - 125	226.75	125	95.9	18	11	19	M4 x 0.7P	3.15
47538	DAT50 x SCK2 - 95	196.75	95	65.9	18.5	14	23.5	M5 x 0.8P	3.20
47540	DAT50 x SCK2 - 125	226.75	125	95.9	18.5	14	23.5	M5 x 0.8P	3.25
47542	DAT50 x SCK3 - 125	226.75	125	95.9	24	18	31	M6 x 1.0P	3.30
47544	DAT50 x SCK3 - 155	256.75	155	125.9	24	18	31	M6 x 1.0P	3.35
47546	DAT50 x SCK4 - 110	211.75	110	80.9	28	22	39	M8 x 1.25P	3.40
47548	DAT50 x SCK4 - 125	226.75	125	95.9	28	22	39	M8 x 1.25P	3.45
47550	DAT50 x SCK5 - 65	166.75	65	35.9	35	28	50	M10 x 1.5P	3.50
47552	DAT50 x SCK5 - 140	241.75	140	110.9	35	28	50	M10 x 1.5P	3.55
47554	DAT50 x SCK6 - 140	241.75	140	110.9	42	36	63	M12 x 1.75P	3.60
47556	DAT50 x SCK6 - 170	271.75	170	140.9	42	36	63	M12 x 1.75P	3.65

Features:

- ▶ Extension spacers are applicable, more convenient for boring.
- ▶ Internal tolerance is H6.

Product information:

- ▶ The pre-balance reaches G6.3 5,000 rpm. Higher balancing grade and revolution can be done upon request but additional charge is needed.
- ▶ AD+B type is available, please inform us when making an order.

Pull Stud	EXTENSION SPACER	SCK	SMB	SBJ	SMU
P.W-57	P.M-51	P.M-3	P.M-12~13	P.M-4	P.M-2



DAT / MCK BORING HEAD SHANK

DAT / MCK 搪孔刀柄

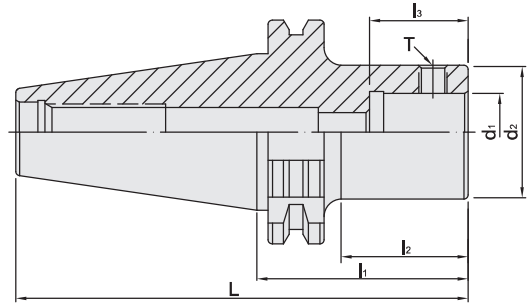

MODEL NO.	TYPE	L	l ₁	l ₂	l ₃	d ₁	d ₂	T	WEIGHT (KGS)
47502M	DAT30 x MCK1 - 50	97.8	50	27.9	18	11	19	M4 x 0.5P	0.60
47504M	DAT30 x MCK2 - 65	112.8	65	42.9	18.5	14	23.5	M5 x 0.5P	0.70
47506M	DAT30 x MCK3 - 50	97.8	50	27.9	24	18	31	M6 x 0.75P	0.80
47508M	DAT30 x MCK4 - 50	97.8	50	27.9	28	22	39	M8 x 0.75P	1.30
47510M	DAT40 x MCK1 - 80	148.4	80	50.9	18	11	19	M4 x 0.5P	1.00
47512M	DAT40 x MCK1 - 95	163.4	95	65.9	18	11	19	M4 x 0.5P	1.05
47514M	DAT40 x MCK2 - 80	148.4	80	50.9	18.5	14	23.5	M5 x 0.5P	1.10
47516M	DAT40 x MCK2 - 110	178.4	110	80.9	18.5	14	23.5	M5 x 0.5P	1.15
47518M	DAT40 x MCK3 - 90	158.4	90	65.9	24	18	31	M6 x 0.75P	1.20
47520M	DAT40 x MCK3 - 125	193.4	125	100.9	24	18	31	M6 x 0.75P	1.25
47522M	DAT40 x MCK4 - 80	148.4	80	55.9	28	22	39	M8 x 0.75P	1.30
47524M	DAT40 x MCK4 - 110	178.4	110	85.9	28	22	39	M8 x 0.75P	1.35
47526M	DAT40 x MCK5 - 95	163.4	95	75.4	35	28	50	M10 x 1.0P	1.40
47528M	DAT40 x MCK5 - 110	178.4	110	90.4	35	28	50	M10 x 1.0P	1.45
47530M	DAT40 x MCK6 - 65	133.4	65	45.4	42	36	63	M12 x 1.0P	1.50
47532M	DAT40 x MCK6 - 95	163.4	95	75.4	42	36	63	M12 x 1.0P	1.55
47534M	DAT50 x MCK1 - 110	211.75	110	80.9	18	11	19	M4 x 0.5P	3.10
47536M	DAT50 x MCK1 - 125	226.75	125	95.9	18	11	19	M4 x 0.5P	3.15
47538M	DAT50 x MCK2 - 95	196.75	95	65.9	18.5	14	23.5	M5 x 0.5P	3.20
47540M	DAT50 x MCK2 - 125	226.75	125	95.9	18.5	14	23.5	M5 x 0.5P	3.25
47542M	DAT50 x MCK3 - 125	226.75	125	95.9	24	18	31	M6 x 0.75P	3.30
47544M	DAT50 x MCK3 - 155	256.75	155	125.9	24	18	31	M6 x 0.75P	3.35
47546M	DAT50 x MCK4 - 110	211.75	110	80.9	28	22	39	M8 x 0.75P	3.40
47548M	DAT50 x MCK4 - 125	226.75	125	95.9	28	22	39	M8 x 0.75P	3.45
47550M	DAT50 x MCK5 - 65	166.75	65	35.9	35	28	50	M10 x 1.0P	3.50
47552M	DAT50 x MCK5 - 140	241.75	140	110.9	35	28	50	M10 x 1.0P	3.55
47554M	DAT50 x MCK6 - 140	241.75	140	110.9	42	36	63	M12 x 1.0P	3.60
47556M	DAT50 x MCK6 - 170	271.75	170	140.9	42	36	63	M12 x 1.0P	3.65
47558M	DAT50 x MCK7 - 95	196.75	95	60	52	46	90	M20 x 1.5P	5.00

Features:

- ▶ Extension spacers are applicable, more convenient for boring.
- ▶ Internal tolerance is H6.

Product information:

- ▶ The pre-balance reaches G6.3 5,000 rpm. Higher balancing grade and revolution can be done upon request but additional charge is needed.
- ▶ AD+B type is available, please inform us when making an order.
- ▶ DAT30 tool holders are without coolant supply over collars.

Pull Stud	EXTENSION SPACER	SCK	SMB	SBJ	SMU	SRW	SMB
P.W-57	P.M-51	P.M-3	P.M-12~13	P.M-4	P.M-2	P.M-14	P.M-16

SBT / SCK BORING HEAD SHANK

Dual
DRIVE+

SBT / SCK 法蘭加厚型搪孔刀柄

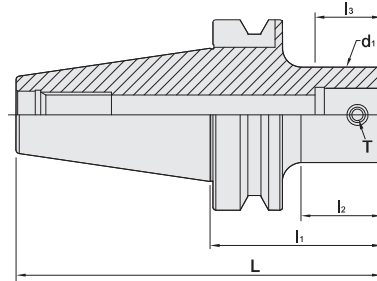

MODEL NO.	TYPE	L	l ₁	l ₂	l ₃	d ₁	T	WEIGHT (KGS)
25.650.02.37.5	SBT30 x SCK2 - 37.5	85.9	37.5	12.5	18.5	23.5	M5 x 0.8P	0.40
25.650.02.82.5	SBT30 x SCK2 - 82.5	130.9	82.5	57.5	18.5	23.5	M5 x 0.8P	0.60
25.650.03.039	SBT30 x SCK3 - 39	87.4	39	13	24	31	M6 x 1.0P	0.50
25.650.03.079	SBT30 x SCK3 - 79	127.4	79	53	24	31	M6 x 1.0P	0.70
25.650.04.038	SBT30 x SCK4 - 38	86.4	38	14	28	39	M8 x 1.25P	0.50
25.650.04.073	SBT30 x SCK4 - 73	121.4	73	49	28	39	M8 x 1.25P	0.80
25.650.05.063	SBT30 x SCK5 - 63	111.4	63	40.5	35	50	M10 x 1.5P	0.85
25.650.06.064	SBT30 x SCK6 - 64	112.4	64	41.5	42	62	M12 x 1.75P	1.35
26.650.02.42.5	SBT40 x SCK2 - 42.5	107.9	42.5	12.5	18.5	23.5	M5 x 0.8P	1.10
26.650.02.82.5	SBT40 x SCK2 - 82.5	147.9	82.5	52.5	18.5	23.5	M5 x 0.8P	1.25
26.650.03.044	SBT40 x SCK3 - 44	109.4	44	13	24	31	M6 x 1.0P	1.15
26.650.03.094	SBT40 x SCK3 - 94	159.4	94	63	24	31	M6 x 1.0P	1.35
26.650.04.043	SBT40 x SCK4 - 43	108.4	43	14	28	39	M8 x 1.25P	1.25
26.650.04.088	SBT40 x SCK4 - 88	153.4	88	56	28	39	M8 x 1.25P	1.55
26.650.05.048	SBT40 x SCK5 - 48	113.4	48	19	35	50	M10 x 1.5P	1.25
26.650.05.078	SBT40 x SCK5 - 78	143.4	78	46	35	50	M10 x 1.5P	1.65
26.650.06.064	SBT40 x SCK6 - 64	129.4	64	36.5	42	63	M12 x 1.75P	1.65

Features:

- ▶ Extension spacers are applicable, more convenient for boring.
- ▶ Internal tolerance is H6.

Product information:

- ▶ The pre-balance reaches G6.3 5,000 rpm. Higher balancing grade and revolution can be done upon request but additional charge is needed.
- ▶ AD+B type is available, please inform us when making an order.
- ▶ SBT30 tool holders are without coolant supply over collars.

Pull Stud	EXTENSION SPACER	SCK	SMB	SBJ	SMU
P.W-54~55	P.M-51	P.M-3	P.M-12~13	P.M-4	P.M-2



SBT / SCK BORING HEAD SHANK

Dual
DRIVE+

SBT / SCK 法蘭加厚型搪孔刀柄

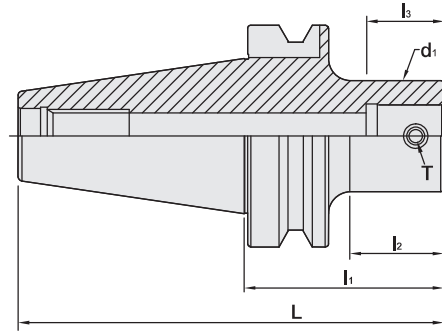

MODEL NO.	TYPE	L	l ₁	l ₂	l ₃	d ₁	T	WEIGHT (KGS)
27.650.02.112.5	SBT50 x SCK2 - 112.5	214.3	112.5	71.5	18.5	23.5	M5 x 0.8P	4.10
27.650.03.124	SBT50 x SCK3 - 124	225.8	124	82	24	31	M6 x 1.0P	4.35
27.650.04.118	SBT50 x SCK4 - 118	219.8	118	75	28	39	M8 x 1.25P	4.55
27.650.04.178	SBT50 x SCK4 - 178	279.8	178	135	28	39	M8 x 1.25P	5.00
27.650.05.108	SBT50 x SCK5 - 108	209.8	108	65	35	50	M10 x 1.5P	4.75
27.650.05.183	SBT50 x SCK5 - 183	284.8	183	140	35	50	M10 x 1.5P	5.95
27.650.05.228	SBT50 x SCK5 - 228	329.8	228	185	35	50	M10 x 1.5P	6.55
27.650.06.094	SBT50 x SCK6 - 94	195.8	94	51	42	63	M12 x 1.75P	4.85
27.650.06.169	SBT50 x SCK6 - 169	270.8	169	126	42	63	M12 x 1.75P	6.75
27.650.06.229	SBT50 x SCK6 - 229	330.8	229	186	42	63	M12 x 1.75P	8.25

Features:

- ▶ Extension spacers are applicable, more convenient for boring.
- ▶ Internal tolerance is H6.

Product information:

- ▶ The pre-balance reaches G6.3 5,000 rpm. Higher balancing grade and revolution can be done upon request but additional charge is needed.
- ▶ AD+B type is available, please inform us when making an order.

Pull Stud	EXTENSION SPACER	SCK	SMB	SBJ	SMU
P.W-54~55	P.M-51	P.M-3	P.M-12~13	P.M-4	P.M-2

SBT / SCK BORING HEAD SHANK

Dual
DRIVE+

SBT / SCK 法蘭加厚型搪孔刀柄

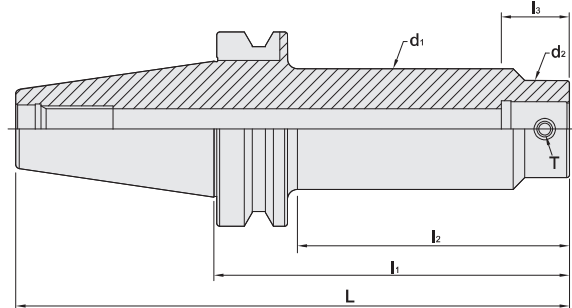

MODEL NO.	TYPE	L	l ₁	l ₂	l ₃	d ₁	d ₂	T	WEIGHT (KGS)
27.681.04.193	SBT50 x SCK4 - 193BG	294.8	193	150	28	48	39	M8 x 1.25P	5.5
27.681.04.238	SBT50 x SCK4 - 238BG	339.8	238	195	28	48	39	M8 x 1.25P	6.1
27.681.05.243	SBT50 x SCK5 - 243BG	344.8	243	200	35	62	50	M10 x 1.5P	8.1
27.681.05.303	SBT50 x SCK5 - 303BG	404.8	303	260	35	62	50	M10 x 1.5P	9.5
27.681.06.259	SBT50 x SCK6 - 259BG	360.8	259	216	42	72	63	M12 x 1.75P	10.3
27.681.06.314	SBT50 x SCK6 - 314BG	415.8	314	271	42	72	63	M12 x 1.75P	12.0
27.681.06.289	SBT50 x SCK6 - 289BG	390.8	289	246	42	80	63	M12 x 1.75P	12.9
27.681.06.349	SBT50 x SCK6 - 349BG	450.8	349	306	42	80	63	M12 x 1.75P	15.2

Features:

- ▶ Extension spacers are applicable, more convenient for boring.
- ▶ Internal tolerance is H6.

Product information:

- ▶ The pre-balance reaches G6.3 5,000 rpm. Higher balancing grade and revolution can be done upon request but additional charge is needed.
- ▶ AD+B type is available, please inform us when making an order.

Pull Stud	EXTENSION SPACER	SCK	SMB	SBJ	SMU
P.W-54~55	P.M-51	P.M-3	P.M-12~13	P.M-4	P.M-2



SBT / MCK BORING HEAD SHANK

Dual
DRIVE+

SBT / MCK 法蘭加厚型搪孔刀柄

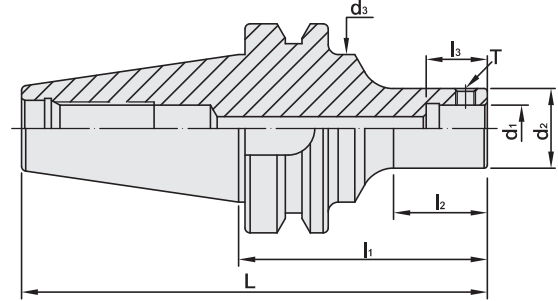

MODEL NO.	TYPE	L	l ₁	l ₂	l ₃	d ₁	d ₂	T	WEIGHT (KGS)
25.487.01.055	SBT30 x MCK1 - 55	103.4	55	28	18	11	19	M4 x 0.5P	0.70
25.487.01.070	SBT30 x MCK1 - 70	118.4	70	43	18	11	19	M4 x 0.5P	0.80
25.487.02.060	SBT30 x MCK2 - 60	108.4	60	33	18.5	14	23.5	M5 x 0.5P	0.80
25.487.02.075	SBT30 x MCK2 - 75	123.4	75	48	18.5	14	23.5	M5 x 0.5P	0.80
25.487.02.080	SBT30 x MCK2 - 80	128.4	80	53	18.5	14	23.5	M5 x 0.5P	0.85
25.487.03.050	SBT30 x MCK3 - 50	98.4	50	26	24	18	31	M6 x 0.75P	0.90
25.487.03.080	SBT30 x MCK3 - 80	128.4	80	56	24	18	31	M6 x 0.75P	0.95
25.487.04.060	SBT30 x MCK4 - 60	108.4	60	37	28	22	39	M8 x 0.75P	1.00
25.487.04.070	SBT30 x MCK4 - 70	118.4	70	47	28	22	39	M8 x 0.75P	1.00
25.487.05.070	SBT30 x MCK5 - 70	118.4	70	47	35	28	50	M10 x 1.0P	1.10
25.487.06.060	SBT30 x MCK6 - 60	108.4	60	38	42	36	63	M12 x 1.0P	1.20
26.487.03.080	SBT40 x MCK3 - 80	145.4	80	48	24	18	31	M6 x 0.75P	1.22
26.487.03.095	SBT40 x MCK3 - 95	160.4	95	63	24	18	31	M6 x 0.75P	1.24
26.487.03.125	SBT40 x MCK3 - 125	190.4	125	93	24	18	31	M6 x 0.75P	1.30
26.487.03.155	SBT40 x MCK3 - 155	220.4	155	123	24	18	31	M6 x 0.75P	1.40
26.487.04.070	SBT40 x MCK4 - 70	135.4	70	40	28	22	39	M8 x 0.75P	1.50
26.487.04.100	SBT40 x MCK4 - 100	165.4	100	70	28	22	39	M8 x 0.75P	1.56
26.487.04.130	SBT40 x MCK4 - 130	195.4	130	98	28	22	39	M8 x 0.75P	1.60
26.487.04.175	SBT40 x MCK4 - 175	240.4	175	143	28	22	39	M8 x 0.75P	1.70
26.487.05.060	SBT40 x MCK5 - 60	125.4	60	30	35	28	50	M10 x 1.0P	1.30
26.487.05.080	SBT40 x MCK5 - 80	145.4	80	51	35	28	50	M10 x 1.0P	1.60
26.487.05.125	SBT40 x MCK5 - 125	190.4	125	96	35	28	50	M10 x 1.0P	1.70
26.487.05.175	SBT40 x MCK5 - 175	240.4	175	146	35	28	50	M10 x 1.0P	1.80
26.487.06.055	SBT40 x MCK6 - 55	120.4	55	28	42	36	63	M12 x 1.0P	2.15
26.487.06.065	SBT40 x MCK6 - 65	130.4	65	38	42	36	63	M12 x 1.0P	2.20
26.487.06.115	SBT40 x MCK6 - 115	170.4	115	88	42	36	63	M12 x 1.0P	2.30
26.487.06.165	SBT40 x MCK6 - 165	230.4	165	138	42	36	63	M12 x 1.0P	2.50

Features:

► Extension spacers are applicable, more convenient for boring. ► Internal tolerance is H6. ► For center coolant (DIN 69871-AD).

Product information:

- The pre-balance reaches G6.3 5,000 rpm. Higher balancing grade and revolution can be done upon request but additional charge is needed.
- AD+B type is available, please inform us when making an order.
- SBT30 tool holders are without coolant supply over collars.

Pull Stud	EXTENSION SPACER	SCK	SMB	SBJ	SMU
P.W-54~55	P.M-51	P.M-3	P.M-12~13	P.M-4	P.M-2

SBT / MCK BORING HEAD SHANK

Dual
DRIVE+

SBT / MCK 法蘭加厚型搪孔刀柄

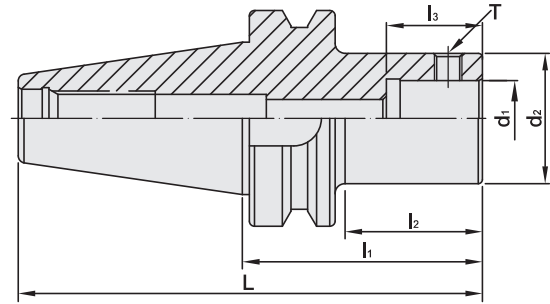

MODEL NO.	TYPE	L	l ₁	l ₂	l ₃	d ₁	d ₂	d ₃	T	WEIGHT (KGS)
26.487.01.100	SBT40 x MCK1 - 100	165.4	100	51	18	11	19	44.45	M4 x 0.5P	1.20
26.487.01.115	SBT40 x MCK1 - 115	180.4	115	66	18	11	19	44.45	M4 x 0.5P	1.30
26.487.02.075	SBT40 x MCK2 - 75	140.4	75	28	18.5	14	23.5	44.45	M5 x 0.5P	1.14
26.487.02.085	SBT40 x MCK2 - 85	150.4	85	38	18.5	14	23.5	44.45	M5 x 0.5P	1.20
26.487.02.115	SBT40 x MCK2 - 115	180.4	115	68	18.5	14	23.5	44.45	M5 x 0.5P	1.25
27.487.01.105	SBT50 x MCK1 - 105	206.8	105	38	18	11	19	69.85	M4 x 0.5P	3.90
27.487.01.115	SBT50 x MCK1 - 115	216.8	115	48	18	11	19	69.85	M4 x 0.5P	4.00
27.487.01.145	SBT50 x MCK1 - 145	246.8	145	78	18	11	19	69.85	M4 x 0.5P	4.10
27.487.02.105	SBT50 x MCK2 - 105	206.8	105	39	18.5	14	23.5	69.85	M5 x 0.5P	4.00
27.487.02.135	SBT50 x MCK2 - 135	236.8	135	67	18.5	14	23.5	69.85	M5 x 0.5P	4.10
27.487.02.140	SBT50 x MCK2 - 140	241.8	140	72	18.5	14	23.5	69.85	M5 x 0.5P	4.20

Features:

- ▶ Extension spacers are applicable, more convenient for boring.
- ▶ Internal tolerance is H6.
- ▶ For center coolant (DIN 69871-AD).

Product information:

- ▶ The pre-balance reaches G6.3 5,000 rpm. Higher balancing grade and revolution can be done upon request but additional charge is needed.
- ▶ AD+B type is available, please inform us when making an order.

Pull Stud	EXTENSION SPACER	SCK	SMB	SBJ	SMU
P.W-54~55	P.M-51	P.M-3	P.M-12~13	P.M-4	P.M-2



SBT / MCK BORING HEAD SHANK

Dual
DRIVE+

SBT / MCK 法蘭加厚型搪孔刀柄

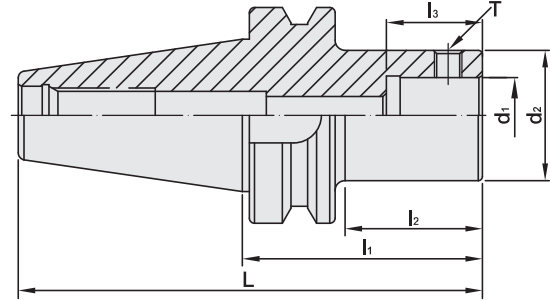

MODEL NO.	TYPE	L	l ₁	l ₂	l ₃	d ₁	d ₂	T	WEIGHT (KGS)
27.487.03.110	SBT50 x MCK3 - 110	211.8	110	62	24	18	31	M6 x 0.75P	4.40
27.487.03.140	SBT50 x MCK3 - 140	241.8	140	92	24	18	31	M6 x 0.75P	4.60
27.487.03.155	SBT50 x MCK3 - 155	256.8	155	107	24	18	31	M6 x 0.75P	4.80
27.487.04.100	SBT50 x MCK4 - 100	201.8	100	52	28	22	39	M8 x 0.75P	4.80
27.487.04.160	SBT50 x MCK4 - 160	261.8	160	112	28	22	39	M8 x 0.75P	5.20
27.487.04.175	SBT50 x MCK4 - 175	276.8	175	127	28	22	39	M8 x 0.75P	2.30
27.487.04.205	SBT50 x MCK4 - 205	306.8	205	205	28	22	39	M8 x 0.75P	5.40
27.487.05.090	SBT50 x MCK5 - 90	191.8	90	42	35	28	50	M10 x 1.0P	5.40
27.487.05.105	SBT50 x MCK5 - 105	206.8	105	57	35	28	50	M10 x 1.0P	5.60
27.487.05.165	SBT50 x MCK5 - 165	266.8	165	117	35	28	50	M10 x 1.0P	6.20
27.487.05.210	SBT50 x MCK5 - 210	311.8	210	162	35	28	50	M10 x 1.0P	6.40
27.487.05.240	SBT50 x MCK5 - 240	341.8	240	192	35	28	50	M10 x 1.0P	6.60
27.487.05.300	SBT50 x MCK5 - 300	401.8	300	252	35	28	50	M10 x 1.0P	6.80
27.487.06.085	SBT50 x MCK6 - 85	186.8	85	37	42	36	63	M12 x 1.0P	5.90
27.487.06.155	SBT50 x MCK6 - 155	256.8	155	107	42	36	63	M12 x 1.0P	6.50
27.487.06.215	SBT50 x MCK6 - 215	316.8	215	167	42	36	63	M12 x 1.0P	6.90
27.487.07.180	SBT50 x MCK7 - 180	281.8	180	139	52	46	90	M20 x 1.5P	5.00
27.487.07.330	SBT50 x MCK7 - 330	431.8	330	289	52	46	90	M20 x 1.5P	12.5

Features:

- ▶ Extension spacers are applicable, more convenient for boring.
- ▶ Internal tolerance is H6.

Product information:

- ▶ The pre-balance reaches G6.3 5,000 rpm. Higher balancing grade and revolution can be done upon request but additional charge is needed.
- ▶ AD+B type is available, please inform us when making an order.

Pull Stud	EXTENSION SPACER	SCK	SMB	SBJ	SMU	SRW	SMB
P.W-54~55	P.M-51	P.M-3	P.M-12~13	P.M-4	P.M-2	P.M-14	P.M-16

SBT / MCK BORING HEAD SHANK

Dual
DRIVE+

SBT / MCK 法蘭加厚型搪孔刀柄

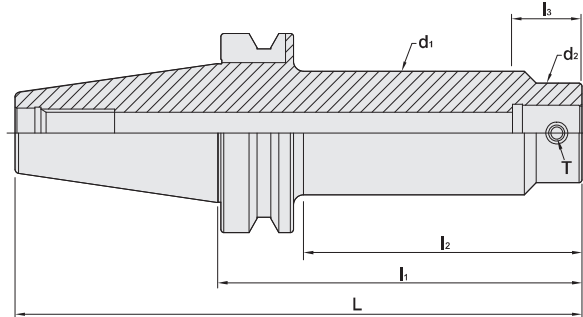

MODEL NO.	TYPE	L	l ₁	l ₂	l ₃	d ₁	d ₂	T	WEIGHT (KGS)
27.487.04.193	SBT50 x MCK4 - 193BG	294.8	193	150	28	48	39	M8 x 0.75P	5.50
27.487.04.238	SBT50 x MCK4 - 238BG	339.8	238	195	28	48	39	M8 x 0.75P	6.10
27.487.05.243	SBT50 x MCK5 - 243BG	344.8	243	200	35	62	50	M10 x 1.0P	8.10
27.487.05.303	SBT50 x MCK5 - 303BG	404.8	303	260	35	62	50	M10 x 1.0P	9.50
27.487.06.259	SBT50 x MCK6 - 259BG	360.8	259	216	42	72	63	M12 x 1.0P	10.3
27.487.06.314	SBT50 x MCK6 - 314BG	415.8	314	271	42	72	63	M12 x 1.0P	12.0
27.487.06.289	SBT50 x MCK6 - 289BG	390.8	289	246	42	80	63	M12 x 1.0P	12.9
27.487.06.349	SBT50 x MCK6 - 349BG	450.8	349	306	42	80	63	M12 x 1.0P	15.2

Features:

- ▶ Extension spacers are applicable, more convenient for boring.
- ▶ Internal tolerance is H6.

Product information:

- ▶ The pre-balance reaches G6.3 5,000 rpm. Higher balancing grade and revolution can be done upon request but additional charge is needed.
- ▶ AD+B type is available, please inform us when making an order.

Pull Stud	EXTENSION SPACER	SCK	SMB	SBJ	SMU
P.W-54~55	P.M-51	P.M-3	P.M-12~13	P.M-4	P.M-2



SCAT / SCK BORING HEAD SHANK

Dual
DRIVE+

SCAT / SCK 法蘭加厚型搪孔刀柄

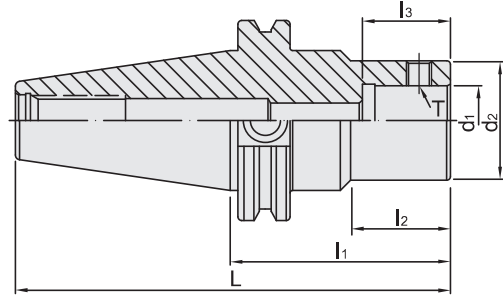

INCHES







MODEL NO.	TYPE	L	l ₁	l ₂	l ₃	d ₁	d ₂	T	WEIGHT (KGS)
43.650.02.300	SCAT40 x SCK2 - 3"	5.687	3	1.39	0.728	0.551	0.925	M5 x 0.8P	1.30
43.650.02.435	SCAT40 x SCK2 - 4.35"	7.037	4.35	2.626	0.728	0.551	0.925	M5 x 0.8P	1.35
43.650.03.300	SCAT40 x SCK3 - 3"	5.687	3	1.356	0.945	0.709	1.22	M6 x 1.0P	1.40
43.650.03.500	SCAT40 x SCK3 - 5"	7.687	5	3.356	0.945	0.709	1.22	M6 x 1.0P	1.45
43.650.04.300	SCAT40 x SCK4 - 3"	5.687	3	1.515	1.102	0.866	1.535	M8 x 1.25P	1.50
43.650.04.425	SCAT40 x SCK4 - 4.25"	6.937	4.25	2.765	1.102	0.866	1.535	M8 x 1.25P	1.55
43.650.05.300	SCAT40 x SCK5 - 3"	5.687	3	1.513	1.378	1.102	1.969	M10 x 1.5P	1.60
43.650.05.425	SCAT40 x SCK5 - 4.25"	6.937	4.25	2.763	1.378	1.102	1.969	M10 x 1.5P	1.65
43.650.06.300	SCAT40 x SCK6 - 3"	5.687	3	1.622	1.653	1.417	2.48	M12 x 1.75P	1.70
43.650.06.425	SCAT40 x SCK6 - 4.25"	6.937	4.25	2.872	1.653	1.417	2.48	M12 x 1.75P	1.75
44.650.02.350	SCAT50 x SCK2 - 3.5"	7.5	3.5	1.368	0.728	0.551	0.925	M5 x 0.8P	3.40
44.650.02.530	SCAT50 x SCK2 - 5.3"	9.3	5.3	3.167	0.728	0.551	0.925	M5 x 0.8P	3.45
44.650.03.350	SCAT50 x SCK3 - 3.5"	7.5	3.5	1.453	0.945	0.709	1.22	M6 x 1.0P	3.50
44.650.03.550	SCAT50 x SCK3 - 5.5"	9.5	5.5	3.453	0.945	0.709	1.22	M6 x 1.0P	3.55
44.650.04.350	SCAT50 x SCK4 - 3.5"	7.5	3.5	1.544	1.102	0.866	1.535	M8 x 1.25P	3.60
44.650.04.550	SCAT50 x SCK4 - 5.5"	9.5	5.5	3.544	1.102	0.866	1.535	M8 x 1.25P	3.65
44.650.05.350	SCAT50 x SCK5 - 3.5"	7.5	3.5	1.669	1.378	1.102	1.969	M10 x 1.5P	3.70
44.650.05.550	SCAT50 x SCK5 - 5.5"	9.5	5.5	3.669	1.378	1.102	1.969	M10 x 1.5P	3.75
44.650.06.350	SCAT50 x SCK6 - 3.5"	7.5	3.5	1.987	1.653	1.417	2.48	M12 x 1.75P	3.80
44.650.06.550	SCAT50 x SCK6 - 5.5"	9.5	5.5	3.987	1.653	1.417	2.48	M12 x 1.75P	3.85

Features:

- ▶ Extension spacers are applicable, more convenient for boring.
- ▶ Internal tolerance is H6.

Product information:

- ▶ The pre-balance reaches G6.3 5,000 rpm. Higher balancing grade and revolution can be done upon request but additional charge is needed.
- ▶ AD+B type is available, please inform us when making an order.

Pull Stud	EXTENSION SPACER	SCK	SMB	SBJ	SMU
					
P.W-56	P.M-51	P.M-3	P.M-12~13	P.M-4	P.M-2

SCAT / MCK BORING HEAD SHANK

Dual
DRIVE+

SCAT / MCK 法蘭加厚型搪孔刀柄

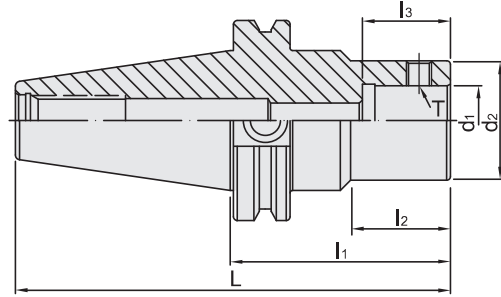

INCHES







MODEL NO.	TYPE	L	l ₁	l ₂	l ₃	d ₁	d ₂	T	WEIGHT (KGS)
43.487.01.300	SCAT40 x MCK1 - 3"	5,687	3	1,105	0,708	0,433	0,748	M4 x 0.5P	1.20
43.487.01.375	SCAT40 x MCK1 - 3.75"	6,437	3.75	1,856	0,708	0,433	0,748	M4 x 0.5P	1.25
43.487.02.300	SCAT40 x MCK2 - 3"	5,687	3	1,39	0,728	0,551	0,925	M5 x 0.5P	1.30
43.487.02.435	SCAT40 x MCK2 - 4.35"	7,037	4.35	2,656	0,728	0,551	0,925	M5 x 0.5P	1.35
43.487.03.300	SCAT40 x MCK3 - 3"	5,687	3	1,356	0,945	0,709	1,22	M6 x 0.75P	1.40
43.487.03.500	SCAT40 x MCK3 - 5"	7,687	5	3,36	0,945	0,709	1,22	M6 x 0.75P	1.45
43.487.04.300	SCAT40 x MCK4 - 3"	5,687	3	1,515	1,102	0,866	1,535	M8 x 0.75P	1.50
43.487.04.425	SCAT40 x MCK4 - 4.25"	6,937	4.25	2,765	1,102	0,866	1,535	M8 x 0.75P	1.55
43.487.05.300	SCAT40 x MCK5 - 3"	5,687	3	2,219	1,378	1,102	1,969	M10 x 1.0P	1.60
43.487.05.425	SCAT40 x MCK5 - 4.25"	6,937	4.25	3,469	1,378	1,102	1,969	M10 x 1.0P	1.65
43.487.06.300	SCAT40 x MCK6 - 3"	5,687	3	2,219	1,653	1,417	2,48	M12 x 1.0P	1.70
43.487.06.425	SCAT40 x MCK6 - 4.25"	6,937	4.25	3,469	1,653	1,417	2,48	M12 x 1.0P	1.75
44.487.01.350	SCAT50 x MCK1 - 3.5"	7,5	3.5	1,317	0,708	0,433	0,748	M4 x 0.5P	3.30
44.487.01.400	SCAT50 x MCK1 - 4"	8	4	1,817	0,708	0,433	0,748	M4 x 0.5P	3.35
44.487.02.350	SCAT50 x MCK2 - 3.5"	7,5	3.5	1,368	0,728	0,551	0,925	M5 x 0.5P	3.40
44.487.02.530	SCAT50 x MCK2 - 5.3"	9,3	5.3	3,167	0,728	0,551	0,925	M5 x 0.5P	3.45
44.487.03.350	SCAT50 x MCK3 - 3.5"	7,5	3.5	1,453	0,945	0,709	1,22	M6 x 0.75P	3.50
44.487.03.550	SCAT50 x MCK3 - 5.5"	9,5	5.5	3,453	0,945	0,709	1,22	M6 x 0.75P	3.55
44.487.04.350	SCAT50 x MCK4 - 3.5"	7,5	3.5	1,544	1,102	0,866	1,535	M8 x 0.75P	3.60
44.487.04.550	SCAT50 x MCK4 - 5.5"	9,5	5.5	3,544	1,102	0,866	1,535	M8 x 0.75P	3.65
44.487.05.350	SCAT50 x MCK5 - 3.5"	7,5	3.5	1,669	1,378	1,102	1,969	M10 x 1.0P	3.70
44.487.05.550	SCAT50 x MCK5 - 5.5"	9,5	5.5	3,669	1,378	1,102	1,969	M10 x 1.0P	3.75
44.487.06.350	SCAT50 x MCK6 - 3.5"	7,5	3.5	1,988	1,653	1,417	2,48	M12 x 1.0P	3.80
44.487.06.550	SCAT50 x MCK6 - 5.5"	9,5	5.5	3,987	1,653	1,417	2,48	M12 x 1.0P	3.85

Features:

- ▶ Extension spacers are applicable, more convenient for boring.
- ▶ Internal tolerance is H6.

Product information:

- ▶ The pre-balance reaches G6.3 5,000 rpm. Higher balancing grade and revolution can be done upon request but additional charge is needed.
- ▶ AD+B type is available, please inform us when making an order.

Pull Stud	EXTENSION SPACER	SCK	SMB	SBJ	SMU
					
P.W-56	P.M-51	P.M-3	P.M-12~13	P.M-4	P.M-2



SDAT / SCK BORING HEAD SHANK

Dual
DRIVE+

SDAT / SCK 法蘭加厚型搪孔刀柄

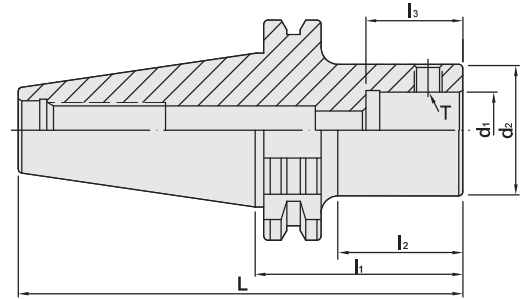

MODEL NO.	TYPE	L	l ₁	l ₂	l ₃	d ₁	d ₂	T	WEIGHT (KGS)
66.650.02.080	SDAT40 x SCK2 - 80	148.4	80	51	18,5	14	23,5	M5 x 0,8P	1.10
66.650.02.110	SDAT40 x SCK2 - 110	178.4	110	81	18,5	14	23,5	M5 x 0,8P	1.15
66.650.03.090	SDAT40 x SCK3 - 90	158.4	90	66	24	18	31	M6 x 1,0P	1.20
66.650.03.125	SDAT40 x SCK3 - 125	193.4	125	101	24	18	31	M6 x 1,0P	1.25
66.650.04.080	SDAT40 x SCK4 - 80	148.4	80	56	28	22	39	M8 x 1,25P	1.30
66.650.04.110	SDAT40 x SCK4 - 110	178.4	110	86	28	22	39	M8 x 1,25P	1.35
66.650.05.095	SDAT40 x SCK5 - 95	163.4	95	75	35	28	50	M10 x 1,5P	1.40
66.650.05.110	SDAT40 x SCK5 - 110	178.4	110	90	35	28	50	M10 x 1,5P	1.45
66.650.06.065	SDAT40 x SCK6 - 65	133.4	65	45	42	36	63	M12 x 1,75P	1.50
66.650.06.095	SDAT40 x SCK6 - 95	163.4	95	75	42	36	63	M12 x 1,75P	1.55
67.650.02.095	SDAT50 x SCK2 - 95	196.75	95	66	18,5	14	23,5	M5 x 0,8P	3.20
67.650.02.125	SDAT50 x SCK2 - 125	226.75	125	96	18,5	14	23,5	M5 x 0,8P	3.25
67.650.03.125	SDAT50 x SCK3 - 125	226.75	125	96	24	18	31	M6 x 1,0P	3.30
67.650.03.155	SDAT50 x SCK3 - 155	256.75	155	126	24	18	31	M6 x 1,0P	3.35
67.650.04.110	SDAT50 x SCK4 - 110	211.75	110	81	28	22	39	M8 x 1,25P	3.40
67.650.04.125	SDAT50 x SCK4 - 125	226.75	125	96	28	22	39	M8 x 1,25P	3.45
67.650.05.065	SDAT50 x SCK5 - 65	166.75	65	36	35	28	50	M10 x 1,5P	3.50
67.650.05.140	SDAT50 x SCK5 - 140	241.75	140	111	35	28	50	M10 x 1,5P	3.55
67.650.06.140	SDAT50 x SCK6 - 140	241.75	140	111	42	36	63	M12 x 1,75P	3.60
67.650.06.170	SDAT50 x SCK6 - 170	271.75	170	141	42	36	63	M12 x 1,75P	3.65

Features:

- ▶ Extension spacers are applicable, more convenient for boring.
- ▶ Internal tolerance is H6.

Product information:

- ▶ The pre-balance reaches G6.3 5,000 rpm. Higher balancing grade and revolution can be done upon request but additional charge is needed.
- ▶ AD+B type is available, please inform us when making an order.

Pull Stud	EXTENSION SPACER	SCK	SMB	SBJ	SMU
P.W-57	P.M-51	P.M-3	P.M-12~13	P.M-4	P.M-2

SDAT / MCK BORING HEAD SHANK

Dual
DRIVE+

SDAT / MCK 法蘭加厚型搪孔刀柄

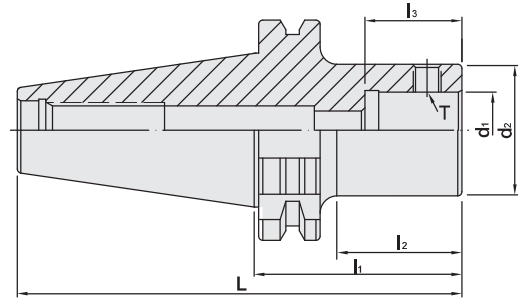

MODEL NO.	TYPE	L	l ₁	l ₂	l ₃	d ₁	d ₂	T	WEIGHT (KGS)
66.487.01.080	SDAT40 x MCK1 - 80	148.4	80	50.9	18	11	19	M4 x 0.5P	1.00
66.487.01.095	SDAT40 x MCK1 - 95	163.4	95	65.9	18	11	19	M4 x 0.5P	1.05
66.487.02.080	SDAT40 x MCK2 - 80	148.4	80	50.9	18.5	14	23.5	M5 x 0.5P	1.10
66.487.02.110	SDAT40 x MCK2 - 110	178.4	110	80.9	18.5	14	23.5	M5 x 0.5P	1.15
66.487.03.090	SDAT40 x MCK3 - 90	158.4	90	65.9	24	18	31	M6 x 0.75P	1.20
66.487.03.125	SDAT40 x MCK3 - 125	193.4	125	100.9	24	18	31	M6 x 0.75P	1.25
66.487.04.080	SDAT40 x MCK4 - 80	148.4	80	55.9	28	22	39	M8 x 0.75P	1.30
66.487.04.110	SDAT40 x MCK4 - 110	178.4	110	85.9	28	22	39	M8 x 0.75P	1.35
66.487.05.095	SDAT40 x MCK5 - 95	163.4	95	75.4	35	28	50	M10 x 1.0P	1.40
66.487.05.110	SDAT40 x MCK5 - 110	178.4	110	90.4	35	28	50	M10 x 1.0P	1.45
66.487.06.065	SDAT40 x MCK6 - 65	133.4	65	45.4	42	36	63	M12 x 1.0P	1.50
66.487.06.095	SDAT40 x MCK6 - 95	163.4	95	75.4	42	36	63	M12 x 1.0P	1.55
67.487.01.110	SDAT50 x MCK1 - 110	211.75	110	80.9	18	11	19	M4 x 0.5P	3.10
67.487.01.125	SDAT50 x MCK1 - 125	226.75	125	95.9	18	11	19	M4 x 0.5P	3.15
67.487.02.095	SDAT50 x MCK2 - 95	196.75	95	65.9	18.5	14	23.5	M5 x 0.5P	3.20
67.487.02.125	SDAT50 x MCK2 - 125	226.75	125	95.9	18.5	14	23.5	M5 x 0.5P	3.25
67.487.03.125	SDAT50 x MCK3 - 125	226.75	125	95.9	24	18	31	M6 x 0.75P	3.30
67.487.03.155	SDAT50 x MCK3 - 155	256.75	155	125.9	24	18	31	M6 x 0.75P	3.35
67.487.04.110	SDAT50 x MCK4 - 110	211.75	110	80.9	28	22	39	M8 x 0.75P	3.40
67.487.04.125	SDAT50 x MCK4 - 125	226.75	125	95.9	28	22	39	M8 x 0.75P	3.45
67.487.05.065	SDAT50 x MCK5 - 65	166.75	65	35.9	35	28	50	M10 x 1.0P	3.50
67.487.05.140	SDAT50 x MCK5 - 140	241.75	140	110.9	35	28	50	M10 x 1.0P	3.55
67.487.06.140	SDAT50 x MCK6 - 140	241.75	140	110.9	42	36	63	M12 x 1.0P	3.60
67.487.06.170	SDAT50 x MCK6 - 170	271.75	170	140.9	42	36	63	M12 x 1.0P	3.65

Features:

- ▶ Extension spacers are applicable, more convenient for boring.
- ▶ Internal tolerance is H6.

Product information:

- ▶ The pre-balance reaches G6.3 5,000 rpm. Higher balancing grade and revolution can be done upon request but additional charge is needed.
- ▶ AD+B type is available, please inform us when making an order.

Pull Stud	EXTENSION SPACER	SCK	SMB	SBJ	SMU
P.W-57	P.M-51	P.M-3	P.M-12~13	P.M-4	P.M-2



HSK / SCK BORING HEAD SHANK

HSK / SCK 搪孔刀柄

[DIN 69893-1]

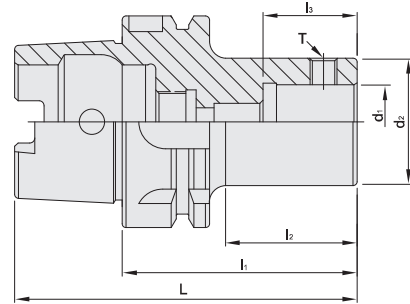

MODEL NO.	TYPE	L	l ₁	l ₂	l ₃	d ₁	d ₂	T	WEIGHT (KGS)
37620	HSK40A x SCK1 - 50	70	50	27	18	11	19	M4 x 0.7P	0.60
37622	HSK40A x SCK2 - 60	80	60	37	18.5	14	23.5	M5 x 0.8P	0.70
37624	HSK40A x SCK3 - 60	80	60	38	24	18	31	M6 x 1.0P	0.80
37630	HSK50A x SCK1 - 60	85	60	31	18	11	19	M4 x 0.7P	1.00
37632	HSK50A x SCK2 - 60	85	60	31	18.5	14	23.5	M5 x 0.8P	1.10
37634	HSK50A x SCK3 - 60	85	60	32	24	18	31	M6 x 1.0P	1.20
37636	HSK50A x SCK4 - 60	85	60	32	28	22	39	M8 x 1.25P	1.30
37638	HSK50A x SCK5 - 80	105	80	53	35	28	50	M10 x 1.5P	1.40
37640	HSK50A x SCK6 - 80	105	80	53	42	36	63	M12 x 1.75P	1.50
37642	HSK63A x SCK1 - 80	112	80	49	18	11	19	M4 x 0.7P	1.20
37644	HSK63A x SCK1 - 95	127	95	64	18	11	19	M4 x 0.7P	1.25
37646	HSK63A x SCK2 - 80	112	80	44	18.5	14	23.5	M5 x 0.8P	1.30
37648	HSK63A x SCK2 - 110	142	110	79	18.5	14	23.5	M5 x 0.8P	1.35
37650	HSK63A x SCK3 - 90	122	90	59	24	18	31	M6 x 1.0P	1.40
37652	HSK63A x SCK3 - 125	157	125	94	24	18	31	M6 x 1.0P	1.45
37654	HSK63A x SCK4 - 80	112	80	49	28	22	39	M8 x 1.25P	1.50
37656	HSK63A x SCK4 - 110	142	110	79	28	22	39	M8 x 1.25P	1.55
37658	HSK63A x SCK5 - 95	127	95	67.5	35	28	50	M10 x 1.5P	1.60
37660	HSK63A x SCK5 - 110	142	110	82.5	35	28	50	M10 x 1.5P	1.65
37662	HSK63A x SCK6 - 70	102	70	43.5	42	36	63	M12 x 1.75P	1.70
37664	HSK63A x SCK6 - 95	127	95	68.5	42	36	63	M12 x 1.75P	1.75

Features:

- ▶ Extension spacers are applicable, more convenient for boring.
- ▶ Internal tolerance is H6.

Product information:

- ▶ The pre-balance reaches G6.3 5,000 rpm. Higher balancing grade and revolution can be done upon request but additional charge is needed.

Coolant Supply Unit	Extension Spacer	SCK	SMB	SBJ	SMU	Key For Coolant Supply Unit
						
P.W-60	P.M-51	P.M-3	P.M-12~13	P.M-4	P.M-2	P.W-60

HSK / SCK BORING HEAD SHANK

HSK / SCK 搪孔刀柄

(DIN 69893-1)

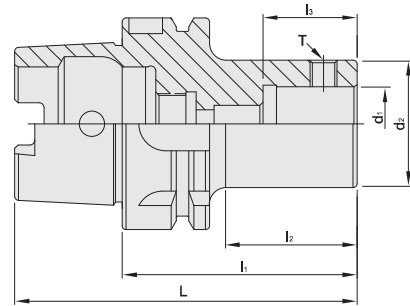

MODEL NO.	TYPE	L	l ₁	l ₂	l ₃	d ₁	d ₂	T	WEIGHT (KGS)
37686 - 100	HSK100A x SCK1 - 100	150	100	61	18	11	19	M4 x 0.7P	2.07
37688	HSK100A x SCK2 - 75	125	75	36	18.5	14	23.5	M5 x 0.8P	2.09
37688 - 115	HSK100A x SCK2 - 115	165	115	76	18.5	14	23.5	M5 x 0.8P	2.18
37690	HSK100A x SCK3 - 60	110	60	21	24	18	31	M6 x 1.0P	2.15
37690 - 125	HSK100A x SCK3 - 125	175	15	86	24	18	31	M6 x 1.0P	2.47
37692	HSK100A x SCK4 - 70	120	70	31	28	22	39	M8 x 1.25P	2.34
37692 - 120	HSK100A x SCK4 - 120	170	120	86	28	22	39	M8 x 1.25P	2.76
37694	HSK100A x SCK5 - 70	120	70	31	35	28	50	M10 x 1.5P	2.60
37694 - 110	HSK100A x SCK5 - 110	160	110	76	35	28	50	M10 x 1.5P	3.17
37696	HSK100A x SCK6 - 75	125	75	41	42	36	63	M12 x 1.75P	3.02
37696 - 100	HSK100A x SCK6 - 100	150	100	66	42	36	63	M12 x 1.75P	3.60

Features:

- ▶ Extension spacers are applicable, more convenient for boring.
- ▶ Internal tolerance is H6.

Product information:

- ▶ The pre-balance reaches G6.3 5,000 rpm. Higher balancing grade and revolution can be done upon request but additional charge is needed.

Coolant Supply Unit	EXTENSION SPACER	SCK	SMB	SBJ	SMU	Key For Coolant Supply Unit
						
P.W-60	P.M-51	P.M-3	P.M-12~13	P.M-4	P.M-2	P.W-60



HSK / MCK BORING HEAD SHANK

HSK / MCK 搪孔刀柄

[DIN 69893-1]

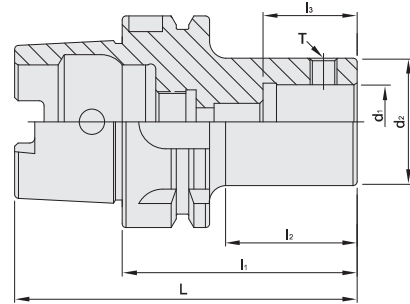

MODEL NO.	TYPE	L	l ₁	l ₂	l ₃	d ₁	d ₂	T	WEIGHT (KGS)
37620M	HSK40A x MCK1 - 50	70	50	27	18	11	19	M4 x 0.5P	0.60
37622M	HSK40A x MCK2 - 60	80	60	37	18.5	14	23.5	M5 x 0.5P	0.70
37624M	HSK40A x MCK3 - 60	80	60	38	24	18	31	M6 x 0.75P	0.80
37630M	HSK50A x MCK1 - 60	85	60	31	18	11	19	M4 x 0.5P	1.00
37632M	HSK50A x MCK2 - 60	85	60	31	18.5	14	23.5	M5 x 0.5P	1.10
37634M	HSK50A x MCK3 - 60	85	60	32	24	18	31	M6 x 0.75P	1.20
37636M	HSK50A x MCK4 - 60	85	60	32	28	22	39	M8 x 0.75P	1.30
37638M	HSK50A x MCK5 - 80	105	80	53	35	28	50	M10 x 1.0P	1.40
37640M	HSK50A x MCK6 - 80	105	80	53	42	36	63	M12 x 1.0P	1.50
37642M	HSK63A x MCK1 - 80	112	80	49	18	11	19	M4 x 0.5P	1.20
37644M	HSK63A x MCK1 - 95	127	95	64	18	11	19	M4 x 0.5P	1.25
37646M	HSK63A x MCK2 - 80	112	80	44	18.5	14	23.5	M5 x 0.5P	1.30
37648M	HSK63A x MCK2 - 110	142	110	79	18.5	14	23.5	M5 x 0.5P	1.35
37650M	HSK63A x MCK3 - 90	122	90	59	24	18	31	M6 x 0.75P	1.40
37652M	HSK63A x MCK3 - 125	157	125	94	24	18	31	M6 x 0.75P	1.45
37654M	HSK63A x MCK4 - 80	112	80	49	28	22	39	M8 x 0.75P	1.50
37656M	HSK63A x MCK4 - 110	142	110	79	28	22	39	M8 x 0.75P	1.55
37658M	HSK63A x MCK5 - 95	127	95	67.5	35	28	50	M10 x 1.0P	1.60
37660M	HSK63A x MCK5 - 110	142	110	82.5	35	28	50	M10 x 1.0P	1.65
37662M	HSK63A x MCK6 - 70	102	70	43.5	42	36	63	M12 x 1.0P	1.70
37664M	HSK63A x MCK6 - 95	127	95	68.5	42	36	63	M12 x 1.0P	1.75

Features:

- ▶ Extension spacers are applicable, more convenient for boring.
- ▶ Internal tolerance is H6.

Product information:

- ▶ The pre-balance reaches G6.3 5,000 rpm. Higher balancing grade and revolution can be done upon request but additional charge is needed.

Coolant Supply Unit	Extension Spacer	SCK	SMB	SBJ	SMU	Key For Coolant Supply Unit
						
P.W-60	P.M-51	P.M-3	P.M-12~13	P.M-4	P.M-2	P.W-60

HSK / MCK BORING HEAD SHANK

HSK / MCK 搪孔刀柄

(DIN 69893-1)

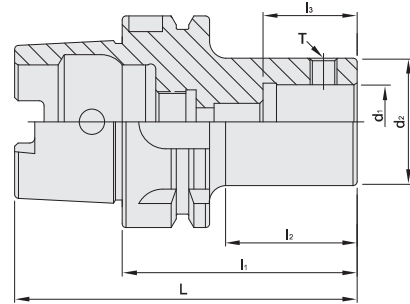

MODEL NO.	TYPE	L	l ₁	l ₂	l ₃	d ₁	d ₂	T	WEIGHT (KGS)
37686M	HSK100A x MCK1 - 100	150	100	61	18	11	19	M4 x 0.5P	2.07
37688M	HSK100A x MCK2 - 75	125	75	36	18.5	14	23.5	M5 x 0.5P	2.09
37688M - 115	HSK100A x MCK2 - 115	165	115	76	18.5	14	23.5	M5 x 0.5P	2.18
37690M	HSK100A x MCK3 - 60	110	60	21	24	18	31	M6 x 0.75P	2.15
37690M - 125	HSK100A x MCK3 - 125	175	15	86	24	18	31	M6 x 0.75P	2.47
37692M	HSK100A x MCK4 - 70	120	70	31	28	22	39	M8 x 0.75P	2.34
37692M - 120	HSK100A x MCK4 - 120	170	120	86	28	22	39	M8 x 0.75P	2.76
37694M	HSK100A x MCK5 - 70	120	70	31	35	28	50	M10 x 1.0P	2.60
37694M - 110	HSK100A x MCK5 - 110	160	110	76	35	28	50	M10 x 1.0P	3.17
37696M	HSK100A x MCK6 - 75	125	75	41	42	36	63	M12 x 1.0P	3.02
37696M - 100	HSK100A x MCK6 - 100	150	100	66	42	36	63	M12 x 1.0P	3.60
37698M	HSK100A x MCK7 - 123	173	123	93	52	46	90	M20 x 1.5P	4.00
37698M - 273	HSK100A x MCK7 - 273	323	273	228	52	46	90	M20 x 1.5P	5.00

Features:

- ▶ Extension spacers are applicable, more convenient for boring.
- ▶ Internal tolerance is H6.

Product information:

- ▶ The pre-balance reaches G6.3 5,000 rpm. Higher balancing grade and revolution can be done upon request but additional charge is needed.

Coolant Supply Unit	EXTENSION SPACER	SCK	SMB	SBJ	SMU	SRW	SMB	Key For Coolant Supply Unit
P.W-60	P.M-51	P.M-3	P.M-12~13	P.M-4	P.M-2	P.M-14	P.M-16	P.W-60



PSC / SCK BORING HEAD SHANK

PSC / SCK 搪頭刀柄

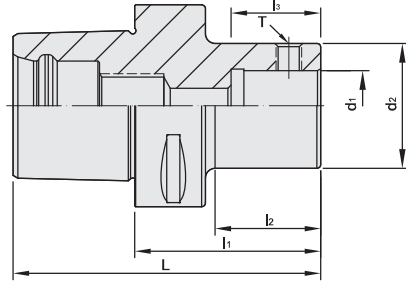

MODEL NO.	TYPE	L	l ₁	l ₂	l ₃	d ₁	d ₂	T	WEIGHT (KGS)
141.650.01.048	PSC40 x SCK1 - 48	72	48	22.5	18	11	19	M4 x 0.7P	0.40
141.650.02.045	PSC40 x SCK2 - 45	69	45	19.5	18.5	14	24	M5 x 0.8P	0.40
141.650.03.040	PSC40 x SCK3 - 40	64	40	17	24	18	31	M6 x 1.0P	0.50
141.650.04.033	PSC40 x SCK4 - 33	57	33	12.5	28	22	39	M8 x 1.25P	0.50
142.650.01.073	PSC50 x SCK1 - 73	103	73	47.5	18	11	19	M4 x 0.7P	0.50
142.650.02.085	PSC50 x SCK2 - 85	115	85	60.5	18.5	14	24	M5 x 0.8P	0.60
142.650.03.055	PSC50 x SCK3 - 55	85	55	30	24	18	31	M6 x 1.0P	0.60
142.650.03.080	PSC50 x SCK3 - 80	110	80	55	24	18	31	M6 x 1.0P	0.70
142.650.04.048	PSC50 x SCK4 - 48	78	48	23	28	22	39	M8 x 1.5P	0.60
142.650.04.073	PSC50 x SCK4 - 73	103	73	48	28	22	39	M8 x 1.5P	0.70
142.650.05.050	PSC50 x SCK5 - 50	80	50	30	35	28	50	M10 x 1.5P	0.60
142.650.05.083	PSC50 x SCK5 - 83	113	83	63	35	28	50	M10 x 1.5P	1.30
142.650.06.050	PSC50 x SCK6 - 50	80	50	30	42	36	63	M12 x 1.75P	1.00
143.650.01.078	PSC63 x SCK1 - 78	116	78	44	18	11	19	M4 x 0.7P	1.20
143.650.02.090	PSC63 x SCK2 - 90	128	90	53	18.5	14	24	M5 x 0.8P	1.30
143.650.03.065	PSC63 x SCK3 - 65	103	65	38	24	18	31	M6 x 1.0P	1.30
143.650.03.100	PSC63 x SCK3 - 100	138	100	73	24	18	31	M6 x 1.0P	1.50
143.650.04.058	PSC63 x SCK4 - 58	96	58	31	28	22	39	M8 x 1.5P	1.30
143.650.04.093	PSC63 x SCK4 - 93	131	93	66	28	22	39	M8 x 1.5P	1.70
143.650.05.048	PSC63 x SCK5 - 48	86	48	22	35	28	50	M10 x 1.5P	1.30
143.650.05.083	PSC63 x SCK5 - 83	121	83	57	35	28	50	M10 x 1.5P	1.70
143.650.06.059	PSC63 x SCK6 - 59	97	59	37	42	36	63	M12 x 1.75P	1.60
143.650.06.094	PSC63 x SCK6 - 94	132	94	72	42	36	63	M12 x 1.75P	2.30

Features:

- ▶ Extension spacers are applicable, more convenient to extend the length.
- ▶ Internal hole tolerance is H6.

Product information:

- ▶ The pre-balance reaches G6.3 5,000rpm. Higher balancing grade and revolution can be done upon request but additional charge is needed.

Coolant Supply unit	Extension Spacer	SCK	SMB	SBJ	SMU
P.W-60	P.M-51	P.M-3	P.M-12~13	P.M-4	P.M-2

PSC / MCK BORING HEAD SHANK

PSC / MCK 搪頭刀柄



台灣精品 2012
TAIWAN EXCELLENCE

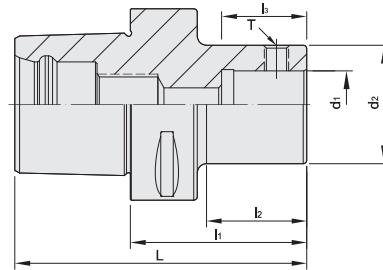

MODEL NO.	TYPE	L	l ₁	l ₂	l ₃	d ₁	d ₂	T	WEIGHT (KGS)
141.487.01.048	PSC40 x MCK1 - 48	72	48	22.5	18	11	19	M4 x 0.5P	0.40
141.487.02.045	PSC40 x MCK2 - 45	69	45	19.5	18.5	14	24	M5 x 0.5P	0.40
141.487.03.040	PSC40 x MCK3 - 40	64	40	17	24	18	31	M6 x 0.75P	0.50
141.487.04.033	PSC40 x MCK4 - 33	57	33	12.5	28	22	39	M8 x 0.75P	0.50
142.487.01.073	PSC50 x MCK1 - 73	103	73	47.5	18	11	19	M4 x 0.5P	0.50
142.487.02.085	PSC50 x MCK2 - 85	115	85	60.5	18.5	14	24	M5 x 0.5P	0.60
142.487.03.055	PSC50 x MCK3 - 55	85	55	30	24	18	31	M6 x 0.75P	0.60
142.487.03.080	PSC50 x MCK3 - 80	110	80	55	24	18	31	M6 x 0.75P	0.70
142.487.04.048	PSC50 x MCK4 - 48	78	48	23	28	22	39	M8 x 0.75P	0.60
142.487.04.073	PSC50 x MCK4 - 73	103	73	48	28	22	39	M8 x 0.75P	0.70
142.487.05.050	PSC50 x MCK5 - 50	80	50	30	35	28	50	M10 x 1.0P	0.60
142.487.05.083	PSC50 x MCK5 - 83	113	83	63	35	28	50	M10 x 1.0P	1.30
142.487.06.050	PSC50 x MCK6 - 50	80	50	30	42	36	63	M12 x 1.0P	1.00
143.487.01.078	PSC63 x MCK1 - 78	116	78	44	18	11	19	M4 x 0.5P	1.20
143.487.02.090	PSC63 x MCK2 - 90	128	90	53	18.5	14	24	M5 x 0.5P	1.30
143.487.03.065	PSC63 x MCK3 - 65	103	65	38	24	18	31	M6 x 0.75P	1.30
143.487.03.100	PSC63 x MCK3 - 100	138	100	73	24	18	31	M6 x 0.75P	1.50
143.487.04.058	PSC63 x MCK4 - 58	96	58	31	28	22	39	M8 x 0.75P	1.30
143.487.04.093	PSC63 x MCK4 - 93	131	93	66	28	22	39	M8 x 0.75P	1.70
143.487.05.048	PSC63 x MCK5 - 48	86	48	22	35	28	50	M10 x 1.0P	1.30
143.487.05.083	PSC63 x MCK5 - 83	121	83	57	35	28	50	M10 x 1.0P	1.70
143.487.06.059	PSC63 x MCK6 - 59	97	59	37	42	36	63	M12 x 1.0P	1.60
143.487.06.094	PSC63 x MCK6 - 94	132	94	72	42	36	63	M12 x 1.0P	2.30

Features:

- ▶ Extension spacers are applicable, more convenient to extend the length.
- ▶ Internal hole tolerance is H6.

Product information:

- ▶ The pre-balance reaches G6.3 5,000rpm. Higher balancing grade and revolution can be done upon request but additional charge is needed.

Coolant Supply unit	Extension Spacer	SCK	SMB	SBJ	SMU
P.W-60	P.M-51	P.M-3	P.M-12~13	P.M-4	P.M-2



PSC / MCK BORING HEAD SHANK

PSC / MCK 搪頭刀柄

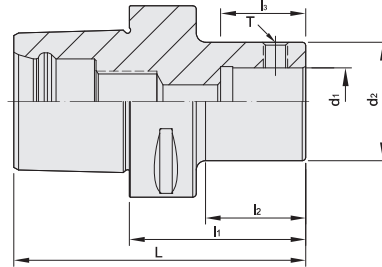

MODEL NO.	TYPE	L	l ₁	l ₂	l ₃	d ₁	d ₂	T	WEIGHT (KGS)
144.487.01.103	PSC80 x MCK1 - 103	151	103	68	18	11	19	M4 x 0.5P	2.60
144.487.02.115	PSC80 x MCK2 - 115	163	115	80	18.5	14	23.5	M5 x 0.5P	2.70
144.487.03.125	PSC80 x MCK3 - 125	173	125	90	24	18	31	M6 x 0.75P	2.90
144.487.04.118	PSC80 x MCK4 - 118	166	118	83	28	22	39	M8 x 0.75P	3.10
144.487.04.178	PSC80 x MCK4 - 178	226	178	138	28	22	39	M8 x 0.75P	3.70
144.487.05.108	PSC80 x MCK5 - 108	156	108	73	35	28	50	M10 x 1.0P	3.50
144.487.05.183	PSC80 x MCK5 - 183	231	183	143	35	28	50	M10 x 1.0P	4.60
144.487.06.074	PSC80 x MCK6 - 74	122	74	39	42	36	63	M12 x 1.0P	3.20
144.487.06.169	PSC80 x MCK6 - 169	217	169	134	42	36	63	M12 x 1.0P	5.80
144.487.07.073	PSC80 x MCK7 - 73	121	73	38	52	46	90	M20 x 1.5P	5.00
144.487.07.123	PSC80 x MCK7 - 123	171	123	88	52	46	90	M20 x 1.5P	8.40

Features:

- ▶ Extension spacers are applicable, more convenient to extend the length.
- ▶ Internal hole tolerance is H6.

Product information:

- ▶ The pre-balance reaches G6.3 5,000rpm. Higher balancing grade and revolution can be done upon request but additional charge is needed.

Coolant Supply unit	Extension Spacer	SCK	SMB	SBJ	SMU	SRW	SMB
P.W-60	P.M-51	P.M-3	P.M-12~13	P.M-4	P.M-2	P.M-14	P.M-16

STRAIGHT SHANK SCK BORING HEAD SHANK

直柄 SCK 搪孔夾頭柄

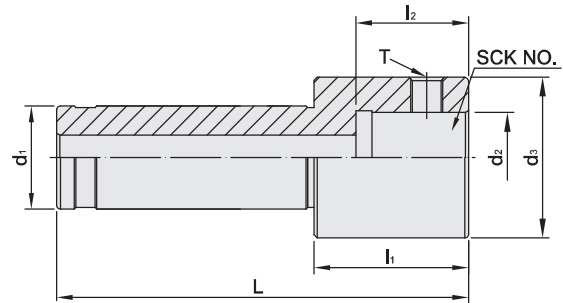

MODEL NO.	TYPE	SCK NO.	L	l ₁	l ₂	d ₁	d ₂	d ₃	T	WEIGHT (KGS)
09572	C32 x SCK1 - 77	SCK1	157	77	18	32	11	19	M4 x 0.7P	0.70
09574	C32 x SCK2 - 72.5	SCK2	152.5	72.5	18.5	32	14	24	M5 x 0.8P	0.70
09576	C32 x SCK3 - 69	SCK3	149	69	24	32	18	31	M6 x 1.0P	0.80
09578	C32 x SCK4 - 58	SCK4	138	58	28	32	22	39	M8 x 1.25P	0.90
09580	C32 x SCK5 - 48	SCK5	128	48	35	32	28	50	M10 x 1.5P	0.90
09582	C32 x SCK6 - 59	SCK6	139	59	42	32	36	63	M12 x 1.75P	1.50
09586	C42 x SCK1 - 77	SCK1	157	77	18	42	11	19	M4 x 0.7P	1.00
09588	C42 x SCK2 - 72.5	SCK2	152.5	72.5	18.5	42	14	24	M5 x 0.8P	1.00
09590	C42 x SCK3 - 69	SCK3	149	69	24	42	18	31	M6 x 1.0P	1.10
09592	C42 x SCK4 - 58	SCK4	138	58	28	42	22	39	M8 x 1.25P	1.20
09594	C42 x SCK5 - 48	SCK5	128	48	35	42	28	50	M10 x 1.5P	1.30
09596	C42 x SCK6 - 59	SCK6	139	59	42	42	36	63	M12 x 1.75P	1.80

Features:

- ▶ Shank tolerance: h6
- ▶ Internal hole tolerance: H6
- ▶ Used with MLD Milling Chuck and suitable for high rigidity processing.
- ▶ Suitable for combining with SCK Rough and Finish Boring Head series.



STRAIGHT SHANK MCK BORING HEAD SHANK

直柄 MCK 搪孔夾頭柄

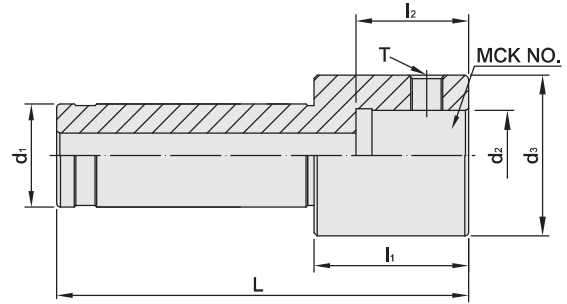

MODEL NO.	TYPE	MCK NO.	L	l ₁	l ₂	d ₁	d ₂	d ₃	T	WEIGHT (KGS)
09572M	C32 x MCK1 - 77	MCK1	157	77	18	32	11	19	M4 x 0.7P	0.70
09574M	C32 x MCK2 - 72.5	MCK2	152.5	72.5	18.5	32	14	24	M5 x 0.8P	0.70
09576M	C32 x MCK3 - 69	MCK3	149	69	24	32	18	31	M6 x 1.0P	0.80
09578M	C32 x MCK4 - 58	MCK4	138	58	28	32	22	39	M8 x 1.25P	0.90
09580M	C32 x MCK5 - 48	MCK5	128	48	35	32	28	50	M10 x 1.5P	0.90
09582M	C32 x MCK6 - 59	MCK6	139	59	42	32	36	63	M12 x 1.75P	1.50
09586M	C42 x MCK1 - 77	MCK1	157	77	18	42	11	19	M4 x 0.7P	1.00
09588M	C42 x MCK2 - 72.5	MCK2	152.5	72.5	18.5	42	14	24	M5 x 0.8P	1.00
09590M	C42 x MCK3 - 69	MCK3	149	69	24	42	18	31	M6 x 1.0P	1.10
09592M	C42 x MCK4 - 58	MCK4	138	58	28	42	22	39	M8 x 1.25P	1.20
09594M	C42 x MCK5 - 48	MCK5	128	48	35	42	28	50	M10 x 1.5P	1.30
09596M	C42 x MCK6 - 59	MCK6	139	59	42	42	36	63	M12 x 1.75P	1.80

Features:

- ▶ Shank tolerance: h6
- ▶ Internal hole tolerance: H6
- ▶ Used with MLD Milling Chuck and suitable for high rigidity processing.
- ▶ Suitable for combining with SCK Rough and Finish Boring Head series.

EXTENSION SPACER

塘孔頭延長桿

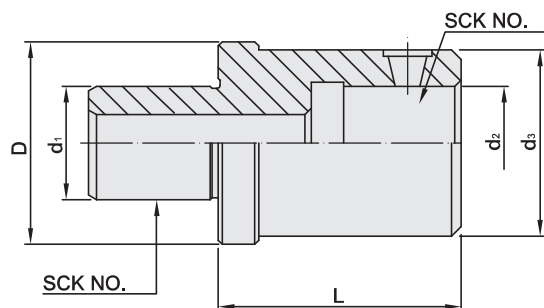

MODEL NO.	TYPE	L	D	d ₁	d ₂	d ₃	WEIGHT (KGS)
17550	SCK1 - 1 - 30	30	-	11	11	19	0.20
17552	SCK2 - 2 - 30	30	-	14	14	24	0.30
17554	SCK3 - 2 - 37	37	31	18	14	24	0.34
17556	SCK3 - 3 - 30	30	-	18	18	31	0.32
17558	SCK4 - 2 - 50	50	39	22	14	24	0.60
17560	SCK4 - 3 - 50	50	39	22	18	31	0.56
17562	SCK4 - 4 - 45	45	-	22	22	39	0.52
17564	SCK5 - 2 - 54	54	49	28	14	24	0.72
17566	SCK5 - 3 - 47	47	49	28	18	31	0.70
17568	SCK5 - 4 - 42	42	49	28	22	39	0.65
17570	SCK5 - 5 - 60	60	-	28	28	50	0.60
17572	SCK6 - 2 - 63	63	64	36	14	24	1.50
17574	SCK6 - 3 - 56	56	64	36	18	31	1.30
17576	SCK6 - 4 - 51	51	64	36	22	39	1.10
17578	SCK6 - 5 - 41	41	64	36	28	50	1.05
17580	SCK6 - 6 - 60	60	-	36	36	63	0.95

PRECISION BT BORING HEAD SHANK

BST 搪孔刀柄

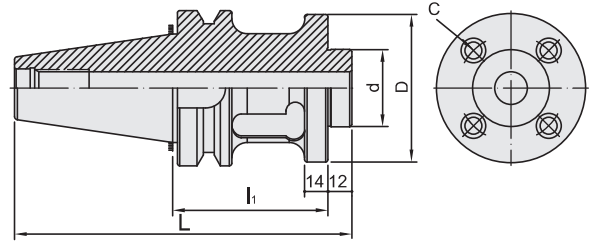

MODEL NO.	TYPE	L	l ₁	D	d h7	C	WEIGHT (KGS)
18422	BT50 x BST - 100	208.8	100	95	50	72	5.65
18424	BT50 x BST - 150	258.8	150	95	50	72	4.00
18426	BT50 x BST - 200	308.8	200	95	50	72	8.75
18428	BT50 x BST - 250	358.8	250	95	50	72	9.76
18430	BT50 x BST - 300	408.8	300	95	50	72	11.5
18432	BT50 x BST - 350	458.8	350	95	50	72	12.8
45230	DAT50 x BST - 150	258.75	150	95	50	72	4.00
45230 - 200	DAT50 x BST - 200	308.75	200	95	50	72	8.75
45230 - 250	DAT50 x BST - 250	358.75	250	95	50	72	9.76

SRW



P.M-15

SMB



P.M-17

NBH BORING HEAD

NBH 高精密搪孔頭

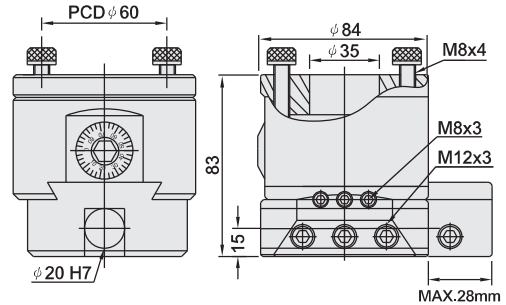

MODEL NO.	TYPE	BORING CAPACITY	BODY DIA	STROKE	MIN FEED	TOOLING DIA	BODY LENGTH	WEIGHT (KGS)
82704	NBH - 2084	8 - 280 mm	84	28	0,01	$\phi 20$	83	2.75

Features:

- ▶ Each increment 0.005mm.
- ▶ Boring range 8mm ~ 280mm.

Product information:

- ▶ Can choose the shank for boring head fit for the machine spindle.
- ▶ Boring head only, not including shank and cutter.

PRECISION BT BORING HEAD SHANK

BT / NBH 搪孔刀柄

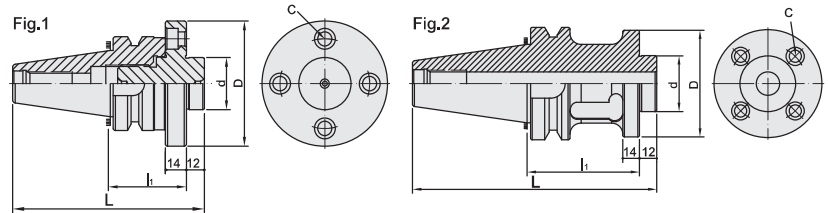

MODEL NO.	TYPE	L	li	D	d h7	C	Fig.	WEIGHT (KGS)
17685	BT30 x NBH2084A	124.4	42	84	35	60	1	1.70
17686	BT40 x NBH2084A	155.4	51	84	35	60	1	1.70
17687	BT50 x NBH2084A	170.8	57	84	35	60	1	3.50
17681	BT30 x NBH2084B - 100	160.4	100	84	35	60	2	1.90
17682	BT40 x NBH2084B - 100	177.4	100	84	35	60	2	2.00
17683	BT50 x NBH2084B - 100	213.8	100	84	35	60	2	4.00
17684	BT50 x NBH2084B - 165	278.8	165	84	35	60	2	4.50

PRECISION DAT BORING HEAD SHANK

DAT / NBH 搪孔刀柄

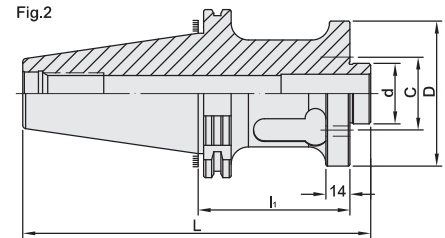
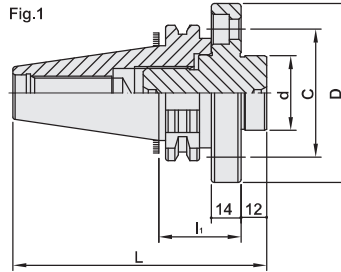

MODEL NO.	TYPE	L	li	D	d h7	C	Fig.	WEIGHT (KGS)
45210	DAT30 x NBH2084A	94.8	35	84	35	60	1	1.70
45215	DAT40 x NBH2084A	115.4	35	84	35	60	1	1.70
45218	DAT50 x NBH2084A	148.75	35	84	35	60	1	3.50
45212	DAT30 x NBH2084B - 100	159.8	100	84	35	60	2	1.90
45217	DAT40 x NBH2084B - 100	180.4	100	84	35	60	2	2.00
45220	DAT50 x NBH2084B	213.75	100	84	35	60	2	4.00

PRECISION BORING HEAD SHANK

搪孔刀柄

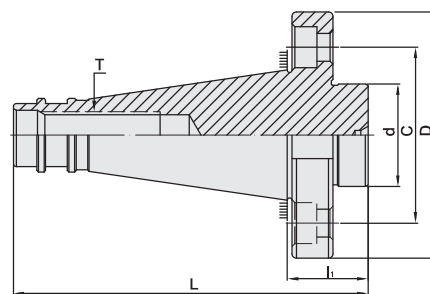

MODEL NO.	TYPE	L	li	D	d	C	T DRAW BAR		WEIGHT (KGS)
82632	C32 x NBH2084	95	14	84	35	60	-	-	1.10
82635	R8 x NBH2084	129	29	84	35	60	7/16" - 20	-	1.10
82638	MTB3 x NBH2084	112	31	84	35	60	M12 x 1.75P	1/2" - 12	1.00
82641	MTB4 x NBH2084	135	32.5	84	35	60	M16 x 2.0P	5/8" - 11	1.30
82644	MTB5 x NBH2084	162	32.5	84	35	60	M24 x 3.0P	1" - 8	2.30
82647	NT30 x NBH2084	96	27.6	84	35	60	M12 x 1.75P	1/2" - 12	0.80
82650	NT40 x NBH2084	121	27.6	84	35	60	M16 x 2.0P	5/8" - 11	1.20
82653	NT50 x NBH2084	168	41.2	84	35	60	M24 x 3.0P	1" - 8	3.50
82656	C32 x SBJ16	135	55	63	36	M12	-	-	1.20
82659	C42 x SBJ16	135	55	63	36	M12	-	-	1.60
82662	R8 x SBJ16	162	55	63	36	M12	7/16" - 20	-	1.20
82665	NT30 x SBJ16	128	59.6	63	36	M12	M12 x 1.75P	1/2" - 12	1.10
82668	NT40 x SBJ16	148	54.6	63	36	M12	M16 x 2.0P	5/8" - 11	1.20
82671	NT50 x SBJ16	215	88.2	63	36	M12	M24 x 3.0P	1" - 8	3.70

PRECISION BORING HEAD SHANK SET

高精密搪孔組

BORING

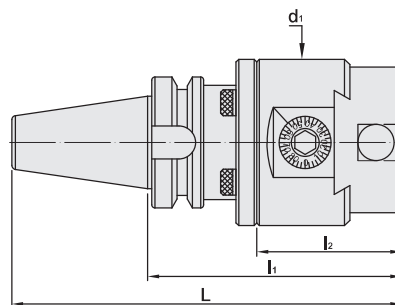

MODEL NO.	TYPE	BORING CAPACITY	L	l ₁	l ₂	d ₁	WEIGHT (KGS)
17695	BT40 x NBH2084	98	200.4	125	83	84	4.60
17696	BT50 x NBH2084	135	242.8	171	83	84	7.50
45115	DAT40 x NBH2084	98	186.4	118	83	84	4.60
45118	DAT50 x NBH2084	135	219.75	118	83	84	7.30
82572	C32 x NBH2084	8 ~ 280	180	100	83	84	3.90
82574	R8 x NBH2084	8 ~ 280	200	100	83	84	3.90
82576	MTB3 x NBH2084	8 ~ 280	181	100	83	84	3.80
82578	MTB4 x NBH2084	8 ~ 280	202.5	100	83	84	4.00
82580	MTB5 x NBH2084	8 ~ 280	229.5	100	83	84	5.10
82582	NT30 x NBH2084	8 ~ 280	168.4	100	83	84	3.60
82584	NT40 x NBH2084	8 ~ 280	193.4	100	83	84	4.00
82586	NT50 x NBH2084	8 ~ 280	226.8	115	83	84	6.30

Features:

- ▶ Contains shank and boring head, but without boring cutters.



BORING HEAD FULL SET

PRECISION

BT / NBH 高精密 套裝搪孔頭



MODEL NO.	TYPE	BORING CAPACITY	BOING CUTTER W/O INSERTS	WRENCH
17675 - 3P	BT40 x NBH2084	8 ~ 280	SBJ-2010-40 / SBJ-2020-83 / SBJ-20-20L	3
17676 - 3P	BT50 x NBH2084	8 ~ 280		3
17675 - 8P	BT40 x NBH2084	8 ~ 280	SBJ-2008-32 / SBJ-2010-40 / SBJ-2012-53 SBJ-2016-68 / SBJ-2020-83 / SBJ-2025-96 SBJ-2030-115 / SBJ-20-20L	3
17676 - 8P	BT50 x NBH2084	8 ~ 280		3

BYB BORING HEAD

MICROMETER ADJUSTABLE

BYB 微切削搪孔頭

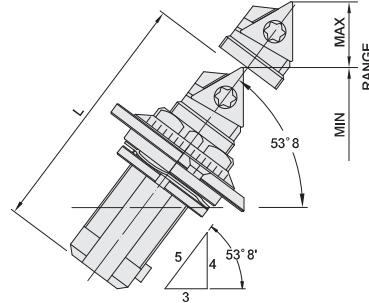

MODEL NO.	TYPE	RANGE		L	INSERT	SCREW	WRENCH	BYB BORING HEAD TYPE	WEIGHT (KGS)
		MIN.	MAX.						
17406	M2 - 19	19	22,5	20,7	TB..0601	M2-3,8-2,68-43	T6	M2 - 19	0,06
17408	M2 - 22	22	29,5	23,5	TB..0601	M2-3,8-2,68-43	T6	M2 - 19	0,06
17410	M3 - 29	29	41	31	TB..0601	M2-3,8-2,68-43	T6	M2 - 19	0,07
17412	M5 - 38	38	50	40	TP..1103	M2,5-7,5-4,3-60	T9	M2 - 22	0,08
17414	M5 - 48	48	65	47,7	TP..1103	M2,5-7,5-4,3-60	T9	M2 - 22	0,10
17416	M7 - 62	62	90	63,5	TP..16T3	M4-10-5,0-60	T15	M3 - 29	0,20

Product information:

- ▶ For the body of boring head, please refer to P.W-58.
- ▶ Inserts are optional accessories. Need to be purchased additionally.

SCK / BYB FINISH BORING HEAD

SCK / BYB 微切削搪刀柄

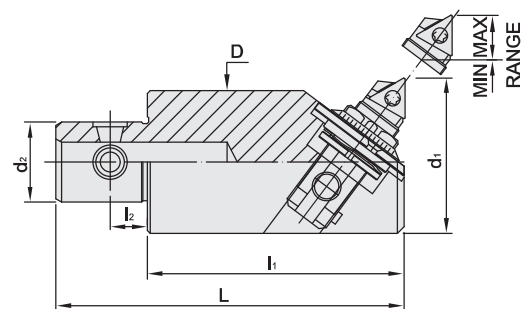

MODEL NO.	TYPE	ASSEMBLE TOOL HOLDER	d ₁		d ₂	L	l ₁	l ₂	D	WEIGHT (KGS)
			MIN.	MAX.						
17382	SCK1 x BYB19	SCK1	19	22,5	11	51	35	4,75	18	0,36
17384	SCK1 x BYB22	SCK1	22	29,5	11	51	35	4,75	20	0,36
17386	SCK2 x BYB29	SCK2	29	41	14	61	45	6,5	25	0,37
17388	SCK3 x BYB38	SCK3	38	50	18	90	70	7,7	35	0,41
17390	SCK4 x BYB48	SCK4	48	65	22	84	60	7,7	41	0,59
17392	SCK5 x BYB62	SCK5	62	90	28	110	80	12,7	54	0,70
17394	SCK6 x BYB82	SCK6	82	110	36	150	110	15,7	67	1,05

Product information:

- ▶ Only contains the body, not including BYB Micrometer Adjustable Boring Head.
- ▶ Inserts are optional accessories. Need to be purchased additionally.



BT / BYB BORING HEAD SHANK

MICROMETER ADJUSTABLE

BT / BYB 微切削搪孔刀柄

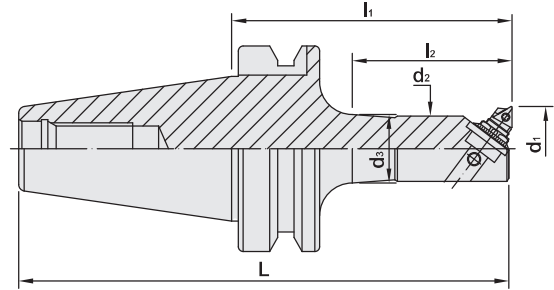



MODEL NO.	TYPE	L	l ₁	l ₂	d ₁		d ₂	d ₃	WEIGHT (KGS)
					MIN.	MAX.			
17423	BT30 x BYB19 - 90	138.4	90	63	19	22.5	18	18	0.70
17424	BT30 x BYB22 - 105	153.4	105	78	22	29.5	20	20	0.70
17425	BT30 x BYB29 - 120	168.4	120	95	29	41	25	25	0.90
17426	BT30 x BYB38 - 120	168.4	120	95	38	50	35	35	1.40
17427	BT30 x BYB48 - 120	168.4	120	95	48	65	41	41	2.10
17433	BT40 x BYB19 - 120	185.4	120	83	19	22.5	18	18	1.50
17434	BT40 x BYB22 - 135	200.4	135	98	22	29.5	20	21	1.50
17435	BT40 x BYB29 - 150	215.4	150	116	29	41	25	27	1.50
17436	BT40 x BYB29 - 180	245.4	180	146	29	41	25	27	2.00
17437	BT40 x BYB38 - 150	215.4	150	113	38	50	35	36	1.80
17438	BT40 x BYB38 - 210	275.4	210	173	38	50	35	36	2.20
17439	BT40 x BYB48 - 150	215.4	150	113	48	65	41	46	2.10
17440	BT40 x BYB48 - 210	275.4	210	173	48	65	41	46	2.30
17441	BT40 x BYB62 - 150	215.4	150	123	62	90	54	60	2.90
17442	BT40 x BYB62 - 210	275.4	210	183	62	90	54	60	3.60
17453	BT50 x BYB19 - 135	236.8	135	85	19	22.5	18	18	3.80
17454	BT50 x BYB22 - 150	251.8	150	100	22	29.5	20	21	3.90
17455	BT50 x BYB29 - 150	251.8	150	100	29	41	25	27	4.50
17456	BT50 x BYB29 - 180	281.8	180	130	29	41	25	27	4.60
17457	BT50 x BYB38 - 165	266.8	165	115	38	50	35	36	4.50
17458	BT50 x BYB38 - 225	326.8	225	175	38	50	35	36	5.00
17459	BT50 x BYB48 - 165	266.8	165	122	48	65	41	40	5.20
17460	BT50 x BYB48 - 210	311.8	210	160	48	65	41	46	5.50
17461	BT50 x BYB48 - 255	356.8	255	205	48	65	41	46	5.70
17462	BT50 x BYB62 - 180	281.8	180	130	62	90	54	53	7.00
17463	BT50 x BYB62 - 240	341.8	240	185	62	90	54	60	7.60
17464	BT50 x BYB62 - 330	431.8	330	280	62	90	54	60	9.50

Features:

- ▶ Graduated dial for micro-adjustment in 0.02mm increments.

Product information:

- ▶ The pre-balance reaches G6.3 5 ,000 rpm. Higher balancing grade and revolution can be done upon request but additional charge is needed.

Pull Stud	BYB Boring Head
 P.W-54~55	 P.M-57

BT SQUARE CUTTER BORING BAR

TYPE : 45°

45° 粗搪孔刀柄

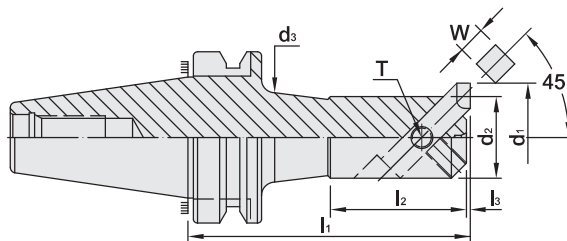

MODEL NO.	TYPE	l ₁	l ₂	l ₃	d ₁		d ₂	d ₃	W	T	WEIGHT (KGS)
					MIN.	MAX.					
17201	BT40 x BSA25 - 120	120	35	1	25	38	20	22	8	M6	1.20
17202	BT40 x BSA30 - 150	150	40	1.6	30	42	24	26	8	M6	1.40
17203	BT40 x BSA38 - 165	165	50	2.6	38	52	30	33	10	M8	1.70
17204	BT40 x BSA42 - 165	165	50	2.6	42	56	34	37	10	M8	2.00
17205	BT40 x BSA50 - 165	165	65	3	50	65	40	44	13	M8	2.30
17206	BT40 x BSA62 - 180	180	80	2	62	90	50	56	16	M10	3.40
17207	BT40 x BSA72 - 180	180	149	2.4	72	110	60	-	19	M10	3.90
17208	BT40 x BSA90 - 180	180	60	4	90	125	75	-	19	M10	5.20
17211	BT50 x BSA25 - 135	135	35	1	25	38	20	22	8	M6	4.20
17212	BT50 x BSA30 - 165	165	40	1.6	30	42	24	26	8	M6	4.40
17213	BT50 x BSA38 - 180	180	50	2.6	38	52	30	33	10	M8	4.80
17214	BT50 x BSA42 - 210	210	50	2.6	42	56	34	37	10	M8	5.00
17215	BT50 x BSA50 - 180	180	65	3	50	65	40	44	13	M10	5.40
17216	BT50 x BSA50 - 240	240	65	3	50	65	40	44	13	M10	5.70
17217	BT50 x BSA62 - 195	195	80	2	62	90	50	56	16	M10	6.20
17218	BT50 x BSA62 - 270	270	80	2	62	90	50	56	16	M10	7.60
17219	BT50 x BSA72 - 195	195	95	2.4	72	110	60	66	19	M10	7.00
17220	BT50 x BSA72 - 285	285	95	2.4	72	110	60	66	19	M10	9.30
17221	BT50 x BSA90 - 210	210	110	4	90	125	75	80	19	M12	9.20
17222	BT50 x BSA90 - 300	300	110	4	90	125	75	80	19	M12	12.3
17223	BT50 x BSA105 - 195	195	153	3	105	160	90	-	25	M12	10.7
17224	BT50 x BSA105 - 285	285	130	3	105	160	90	94	25	M12	15.0
17225	BT50 x BSA130 - 255	255	120	3	130	190	110	-	25	M12	14.5

Product information:

- ▶ The pre-balance reaches G6.3 5,000 rpm. Higher balancing grade and revolution can be done upon request but additional charge is needed.

Pull Stud



P.W-54~55



BT SQUARE CUTTER BORING BAR

TYPE : 90°

90° 粗搪孔刀柄

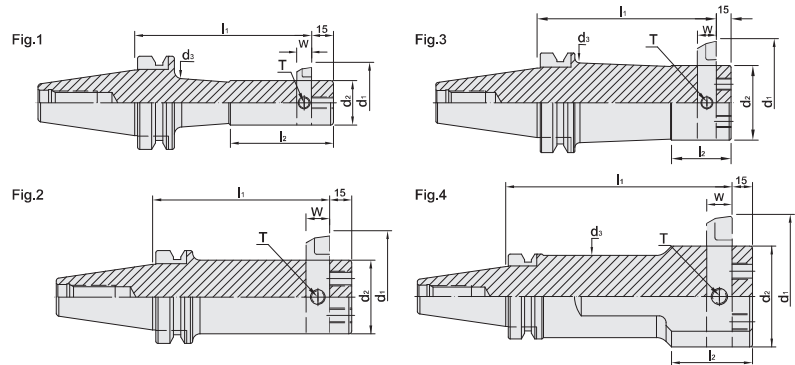

MODEL NO.	TYPE	l ₁	l ₂	d ₁		d ₂	d ₃	W	T	Fig	WEIGHT (KGS)
				MIN.	MAX						
17252	BT40 x BSB25 - 135	135	50	25	52	20	22	8	M6	1	1.30
17254	BT40 x BSB38 - 150	150	70	38	70	30	33	10	M8	1	2.00
17256	BT40 x BSB50 - 165	165	85	50	90	40	44	13	M10	1	2.50
17258	BT40 x BSB62 - 180	180	95	62	115	50	-	16	M10	3	3.70
17260	BT40 x BSB72 - 180	180	-	72	135	60	-	19	M10	2	4.70
17262	BT40 x BSB90 - 180	180	60	90	150	75	61	19	M12	4	5.20
17272	BT50 x BSB25 - 135	135	50	25	52	20	22	8	M6	1	4.20
17274	BT50 x BSB38 - 180	180	70	38	70	30	33	10	M8	1	4.90
17276	BT50 x BSB50 - 180	180	85	50	90	40	44	13	M10	1	5.50
17278	BT50 x BSB50 - 240	240	85	50	90	40	44	13	M10	1	5.80
17280	BT50 x BSB62 - 195	195	-	62	115	50	-	16	M10	2	6.40
17282	BT50 x BSB62 - 270	270	-	62	115	50	-	16	M10	2	7.80
17284	BT50 x BSB72 - 195	195	95	72	135	60	-	19	M10	3	7.30
17286	BT50 x BSB72 - 285	285	95	72	135	60	-	19	M10	3	9.60
17288	BT50 x BSB90 - 210	210	60	90	150	75	80	19	M12	3	9.70
17290	BT50 x BSB90 - 300	300	60	90	150	75	80	19	M12	3	12.8
17292	BT50 x BSB105 - 195	195	-	105	190	90	-	25	M12	2	11.4
17294	BT50 x BSB105 - 285	285	-	105	190	90	-	25	M12	2	15.7
17296	BT50 x BSB130 - 255	225	75	130	260	110	98	25	M12	4	14.1

Product information:

- ▶ The pre-balance reaches G6.3 5,000 rpm. Higher balancing grade and revolution can be done upon request but additional charge is needed.

Pull Stud



P.W-54~55

THROW AWAY BORING CUTTER

SBS 捨棄式搪孔刀

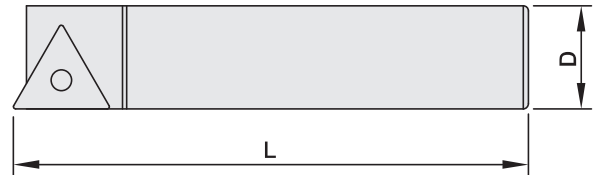

MODEL NO.	TYPE	D	L	ANGLE	INSERTS	SCREW	WRENCH	TORQUE (N.m)	WEIGHT (KGS)
17230	SBS - 308	8	55	30°	TP.0902	M2,5-6,0-3,5-60	T8	1.2	0.04
17231	SBS - 310	10	65	30°	TP.0902	M2,5-6,0-3,5-60	T8	1.2	0.06
17232	SBS - 313	13	80	30°	TP.1103	M3-8,0-4,0-43	T9	1.4	0.11
17233	SBS - 316	16	120	30°	TP.1103	M3-8,0-4,0-43	T9	1.4	0.24
17234	SBS - 319	19	140	30°	TP.1603	M4-10-5,0-43	T15	3.0	0.40
17235	SBS - 325	25	150	30°	TP.1603	M4-10-5,0-43	T15	3.0	0.74
17236	SBS - 408	8	55	45°	TP.0902	M2,5-6,0-3,5-60	T8	1.2	0.04
17237	SBS - 410	10	65	45°	TP.0902	M2,5-6,0-3,5-60	T8	1.2	0.06
17238	SBS - 413	13	80	45°	TP.1103	M3-8,0-4,0-43	T9	1.4	0.11
17239	SBS - 416	16	120	45°	TP.1103	M3-8,0-4,0-43	T9	1.4	0.24
17240	SBS - 419	19	140	45°	TP.1603	M4-10-5,0-43	T15	3.0	0.40
17241	SBS - 425	25	150	45°	TP.1603	M4-10-5,0-43	T15	3.0	0.74
17242	SBS - 908	8	55	90°	TP.0902	M2,5-6,0-3,5-60	T8	1.2	0.04
17243	SBS - 910	10	65	90°	TP.0902	M2,5-6,0-3,5-60	T8	1.2	0.06
17244	SBS - 913	13	80	90°	TP.1103	M3-8,0-4,0-43	T9	1.4	0.11
17245	SBS - 916	16	120	90°	TP.1103	M3-8,0-4,0-43	T9	1.4	0.24
17246	SBS - 919	19	140	90°	TP.1603	M4-10-5,0-43	T15	3.0	0.40
17247	SBS - 925	25	150	90°	TP.1603	M4-10-5,0-43	T15	3.0	0.74

Product information:

- ▶ Inserts are optional accessories. Needs to be purchased additionally.



THROW AWAY BORING CUTTER

CBS 捨棄式搪孔刀

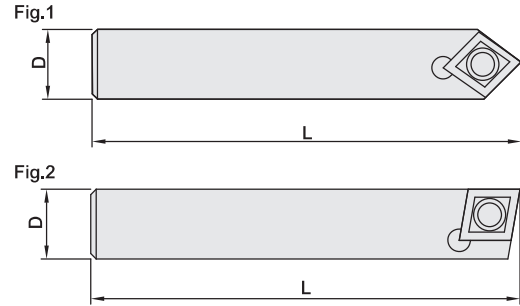

MODEL NO.	TYPE	D	L	ANGLE	INSERTS	SCREW	WRENCH	TORQUE (N.m)	Fig.	WEIGHT (KGS)
17301	CBS - 308	8	55	30°	CC..0602	M2.5-6.0-3.5-60	T8	1.4	1	0.04
17302	CBS - 310	10	65	30°	CC..0602	M2.5-6.0-3.5-60	T8	1.4	1	0.06
17303	CBS - 313	13	80	30°	CC..09T3	M4-10-5.7-60	T15	2.0	1	0.12
17304	CBS - 316	16	120	30°	CC..09T3	M4-10-5.7-60	T15	2.0	1	0.27
17305	CBS - 319	19	140	30°	CC..1204	M5-11-7.5-60	T20	3.0	1	0.41
17306	CBS - 408	8	55	45°	CC..0602	M2.5-6.0-3.5-60	T8	1.4	1	0.04
17307	CBS - 410	10	65	45°	CC..09T3	M4-10-5.7-60	T15	1.4	1	0.06
17308	CBS - 413	13	80	45°	CC..09T3	M4-10-5.7-60	T15	2.0	1	0.12
17309	CBS - 416	16	120	45°	CC..1204	M5-11-7.5-60	T20	2.0	1	0.27
17310	CBS - 419	19	140	45°	CC..1204	M5-11-7.5-60	T20	3.0	1	0.41
17311	CBS - 908	8	55	90°	CC..0602	M2.5-6.0-3.5-60	T8	1.4	1	0.04
17312	CBS - 910	10	65	90°	CC..0602	M2.5-6.0-3.5-60	T8	1.4	1	0.06
17313	CBS - 913	13	80	90°	CC..09T3	M4-10-5.7-60	T15	2.0	1	0.12
17314	CBS - 916	16	120	90°	CC..09T3	M4-10-5.7-60	T15	2.0	1	0.27
17315	CBS - 919	19	140	90°	CC..1204	M5-11-7.5-60	T20	3.0	1	0.41
17316	CBS - 908L	8	55	90°	CC..0602	M2.5-6.0-3.5-60	T9	1.4	2	0.04
17317	CBS - 910L	10	65	90°	CC..0602	M2.5-6.0-3.5-60	T9	1.4	2	0.06
17318	CBS - 913L	13	80	90°	CC..09T3	M4-10-5.7-60	T15	2.0	2	0.12
17319	CBS - 916L	16	120	90°	CC..09T3	M4-10-5.7-60	T15	2.0	2	0.27
17320	CBS - 919L	19	140	90°	CC..1204	M5-11-7.5-60	T20	3.0	2	0.41

Product information:

- ▶ Inserts are optional accessories. Needs to be purchased additionally.